

Warnings and Cautions

This Section provides warnings and cautions pertinent to this product, that if not heeded, may result in personal injury, fatality, or equipment damage. Yaskawa is not responsible for consequences of ignoring these instructions.

WARNING

YASKAWA manufactures component parts that can be used in a wide variety of industrial applications. The selection and application of YASKAWA products remain the responsibility of the equipment designer or end user. YASKAWA accepts no responsibility for the way its products are incorporated into the final system design. Under no circumstances should any YASKAWA product be incorporated into any product or design as the exclusive or sole safety control. Without exception, all controls should be designed to detect faults dynamically and fail safely under all circumstances. All products designed to incorporate a component part manufactured by YASKAWA must be supplied to the end user with appropriate warnings and instructions as to that part's safe use and operation. Any warnings provided by YASKAWA must be promptly provided to the end user. YASKAWA offers an express warranty only as to the quality of its products in conforming to standards and specifications published in the YASKAWA manual. **NO OTHER WARRANTY, EXPRESS OR IMPLIED, IS OFFERED.** YASKAWA assumes no liability for any personal injury, property damage, losses, or claims arising from misapplication of its products.

WARNING

- Read and understand this manual before installing, operating, or servicing this Drive. All warnings, cautions, and instructions must be followed. All activity must be performed by qualified personnel. The Drive must be installed according to this manual and local codes.
- Do not connect or disconnect wiring while the power is on. Do not remove covers or touch circuit boards while the power is on. Do not remove or insert the digital operator while power is on.
- Before servicing, disconnect all power to the equipment. The internal capacitor remains charged even after the power supply is turned off. The charge indicator LED will extinguish when the DC bus voltage is below 50Vdc. To prevent electric shock, wait at least five minutes after all indicators are OFF and measure DC bus voltage level to confirm safe level.
- Do not perform a withstand voltage test on any part of the unit. This equipment uses sensitive devices and may be damaged by high voltage.

WARNING

- The Drive is suitable for circuits capable of delivering not more than 100,000 RMS symmetrical Amperes, 240Vac maximum (200V Class) and 480Vac maximum (400V Class). Install adequate branch circuit short circuit protection per applicable codes. Failure to do so may result in equipment damage and/or personal injury. Refer to Appendix E for further details.
- Do not connect unapproved LC or RC interference suppression filters, capacitors, or overvoltage protection devices to the output of the Drive. These devices may generate peak currents that exceed Drive specifications.

- To avoid unnecessary fault displays caused by contactors or output switches placed between Drive and motor, auxiliary contacts must be properly integrated into the control logic circuit.
- YASKAWA is not responsible for any modification of the product made by the user; doing so will void the warranty. This product must not be modified.
- Verify that the rated voltage of the Drive matches the voltage of the incoming power supply before applying power.
- To meet CE directives, proper line filters and proper installation are required.
- Some drawings in this manual may be shown with protective covers or shields removed, to describe details. These must be replaced before operation.
- Observe electrostatic discharge procedures when handling circuit boards to prevent ESD damage.
- The equipment may start unexpectedly upon application of power. Clear all personnel from the Drive, motor, and machine area before applying power. Secure covers, couplings, shaft keys, and machine loads before energizing the Drive.
- Please do not connect or operate any equipment with visible damage or missing parts. The operating company is responsible for any injuries or equipment damage resulting from failure to heed the warnings in this manual.

■ Intended Use

Drives are intended for installation in electrical systems or machinery.

The Drives are designed and manufactured in accordance with applicable UL and cUL standards, and CE directives.

For use in the European Union, the installation in machinery and systems must conform to the following product standards of the Low Voltage Directive:

EN 50178: 1997-10, Electronic Equipment for Use in Power Installations

EN 60201-1: 1997-12 Machine Safety and Equipping with Electrical Devices
Part 1: General Requirements (IEC 60204-1:1997)

EN 61010: 1997-11 Safety Requirements for Information Technology Equipment
(IEC 950:1991 + A1:1992 + A2:1993 + A3:1995 + A4:1996, modified)

The F7 series Drives comply with the provisions of the Low Voltage Directive 73/23/EEC as amended by 93/68/EEC. These Drives conform to the following standard: EN 50178: 1997-10.

Your supplier or Yaskawa representative must be contacted when using leakage current circuit breaker in conjunction with frequency inverters.

In certain systems it may be necessary to use additional monitoring and safety devices in compliance with the relevant safety and accident prevention regulations. The frequency inverter hardware must not be modified.

Introduction

This section describes the applicability of the manual.

This manual is applicable to F7 Drives defined by model numbers of CIMR-F7U□□□□.

The F7 Drive is a Pulse Width Modulated Drive for AC 3-Phase induction motors. This type of Drive is also known as an Adjustable Frequency Drive, Variable Frequency Drive, AC Drive, AFD, ASD, VFD, VSD, and Inverter. In this manual, the F7 Drive will be referred to as the “Drive”.

The LCD keypad/operator is equipped with local/remote functions, copy feature, 7 language choices, and 5 lines of display with 16 characters per line. User parameter settings can be recovered at any time via “user initialization” when enabled. Optional Drive Wizard software allows upload/download, as well as graphing and monitoring of Drive parameters from a PC for ease of Drive management.

This manual may describe trademarked equipment, which is the property of other companies, who are the registered owners.

Other Documents and Manuals are available to support special use or installation of this product. These documents may be provided with the product or upon request. Contact Yaskawa Electric America, Inc. as required. Documents may include the following:

TM.F7.02.Programming...Manual included on CD ROM with product

TM.F7.01....Manual included on CD ROM with product

DriveWizard...Software and Manual...Included on CD ROM with product

Option Instructions... Included on CD ROM with product

This manual is subject to change as product improvements occur. The latest version of the manual can be obtained from the Yaskawa website: www.drives.com. The date shown on the rear cover is changed when revisions are made. The latest version of Drive software is also shown.

The Drive’s capacity is categorized based on two types of load characteristics: Heavy Duty and Normal Duty. See Table i.1 below for the differences between Heavy Duty and Normal Duty.

Parameter C6-01	Rated Output Current	Overload Capacity	Current Limit	Carrier Frequency	Maximum Output Frequency
0: Heavy Duty (default)	Standard rating (varies by model*)	150% for 1 min.	150%	Low (2kHz)	300Hz
2: Normal Duty	Extended rating (varies by model*)	Approx. 110% for 1 min. (varies by model*)	120%	High (varies by model*)	400Hz

* See Drive Specifications

This manual references the various Drive capacities according to its model number CIMR-F7U□□□□. See Drive Output Specifications Table i.2 and Table i.3 on the following pages for rated capacities and Drive specifications.

Drive Output Specifications

The standard Drive specifications are listed in the following tables.

◆ 208-240Vac

Table i.2 208-240Vac Drive Specifications																				
Model Number CIMR-F7U		208-240Vac											208-230Vac							
		20P4	20P7	21P5	22P2	23P7	25P5	27P5	2011	2015	2018	2022	2030	2037	2045	2055	2075	2090	2110	
Output ratings	Heavy Duty	Rated output capacity*2 (kVA)	1.2	1.6	2.7	3.7	5.7	8.8	12.0	17.0	22.0	27.0	32.0	44.0	55.0	69.0	82.0	110.0	130.0	160.0
		Horsepower*1, 2, 3	0.5/0.75	0.75	1/1.5/2	3	3	5/7.5	10	15	20	25	30	40	50	60	75	100	125	150
		Rated output current*2 (A)	3.2	4.1	7.0	9.6	15.0	23.0	31.0	45.0	58.0	71	85.0	115.0	145.0	180.0	215	283.0	346.0	415.0
		Overload capacity*2	150% of rated output current for 60 seconds																	
		Current limit*2	150% of rated output current																	
		Carrier frequency*2	2kHz																	
		Maximum output frequency*2	300.0Hz																	
	Normal Duty	Rated output capacity*2 (kVA)	1.4	1.8	3.0	4.1	6.4	8.8	12.0	18.0	23.0	29.0	34.0	44.0	62.0	73.0	82.0	120.0	140.0	160.0
		Horsepower*1, 2, 3	0.5/0.75	1	1.5/2	3	5	7.5	10	15	20	25	30	40	50/60	75	75	100/125	150	150
		Rated output current*2 (A)	3.6	4.6	7.8	10.8	16.8	23.0	31.0	46.2	59.4	74.8	88.0	115.0	162.0	192.0	215	312.0	360.0	415.0
		Overload capacity*2 (% of rated output current for 60 sec.)	107	107	108	107	107	120	102	117	117	114	116	120	107	113	120	109	115	120
		Current limit*2	120% of rated output current																	
		Carrier frequency*2 (kHz)	10	10	10	8	10	15	15	8	10	10	10	10	5	5	8	2	2	2
		Maximum output frequency*2	400.0Hz																	
Maximum output voltage	3-phase; 200, 208, 220, 230, or 240Vac (Proportional to input voltage)																			
*1 The maximum applicable motor output is given for a standard 4-pole motor. When selecting the actual motor and Drive, be sure that the Drive's rated output current is appropriate for the motor's rated current.																				
*2 The difference between Heavy Duty ratings and the Normal Duty ratings for the Drive are the rated input and output current, overload capacity, carrier frequency, current limit, and maximum output frequency. Parameter C6-01 must be set to value of "0" for Heavy Duty ratings and "2" for Normal Duty ratings. Factory default is Heavy Duty (C6-01=0).																				
*3 Horsepower ratings are based on 230V or 460V NEC Table 430.150.																				

◆ 480Vac

Table i.3 480Vac Drive Specifications

Model Number CIMR-F7U		40P4	40P7	41P5	42P2	43P7	44P0	45P5	47P5	4011	4015	4018	4022		
Output ratings	Heavy Duty	Rated output capacity* ² (kVA)	1.4	1.6	2.8	4.0	5.8	6.6	9.5	13.0	18.0	24.0	30.0	34.0	
		Horsepower* ^{1,2,3}	0.5/0.75	1	1.5/2	3	5	-	7.5	10	15	20	25	30	
		Rated output current* ² (A)	1.8	2.1	3.7	5.3	7.6	8.7	12.5	17.0	24.0	31.0	39.0	45.0	
		Overload capacity* ²	150% of rated output current for 60 seconds												
		Current limit* ²	150% of rated output current												
		Carrier frequency* ²	2kHz												
		Maximum output frequency* ²	300.0Hz												
	Normal Duty	Rated output capacity* ² (kVA)	1.4	1.6	2.8	4.0	5.8	6.6	9.5	13.0	21.0	26.0	30.0	38.0	
		Horsepower* ^{1,2,3}	0.5/0.75	1	1.5/2	3	5	-	7.5	10	15/20	25	30	30	
		Rated output current* ² (A)	1.8	2.1	3.7	5.3	7.6	8.7	12.5	17.0	27.0	34.0	40.0	50.4	
		Overload capacity* ² (% of rated output current for 60 sec.)	120	120	120	120	120	120	120	120	120	107	109	117	107
		Current limit* ²	120% of rated output current												
		Carrier frequency* ² (kHz)	15	15	15	15	15	15	15	15	15	8	10	10	10
		Maximum output frequency* ²	400.0Hz												
Maximum output voltage		3-phase; 380, 400, 415, 440, 460, or 480Vac (Proportional to input voltage)													
Model Number CIMR-F7U		4030	4037	4045	4055	4075	4090	4110	4132	4160	4185	4220	4300		
Output ratings	Heavy Duty	Rated output capacity* ² (kVA)	46.0	57.0	69.0	85.0	110.0	140.0	160.0	200.0	230.0	280.0	390.0	510.0	
		Horsepower* ^{1,2,3}	40	50	60	75	100	125/150	-	200	250	300	350/400	450/500+	
		Rated output current* ² (A)	60.0	75.0	91.0	112.0	150.0	180.0	216.0	260.0	304.0	370.0	506.0	675.0	
		Overload capacity* ²	150% of rated output current for 60 seconds												
		Software CLA* ²	150% of rated output current												
		Carrier frequency* ²	2kHz												
		Maximum output frequency* ²	300.0Hz												
	Normal Duty	Rated output capacity* ² (kVA)	51.0	59.0	73.0	95.0	120.0	140.0	180.0	200.0	230.0	315.0	390.0	510.0	
		Horsepower* ^{1,2,3}	40/50	60	75	100	125	150	200	-	250	300/350	400/450	500+	
		Rated output current* ² (A)	67.2	77.0	96.0	125.0	156.0	180.0	240.0	260.0	304.0	414.0	515.0	675.0	
		Overload capacity* ² (% of rated output current for 60 sec.)	107	117	114	108	115	120	108	120	120	107	118	120	
		Software CLA* ²	120% of rated output current												
		Carrier frequency* ² (kHz)	8	8	8	5	5	8	5	5	5	2	2	2	
		Maximum output frequency* ²	400.0Hz												
Maximum output voltage		3-phase, 380, 400, 415, 440, 460 or 480Vac (Proportional to input voltage)													
*1 The maximum applicable motor output is given for a standard 4-pole motor. When selecting the actual motor and Drive, be sure that the Drive's rated output current is appropriate for the motor's rated current.															
*2 The difference between Heavy Duty ratings and the Normal Duty ratings for the Drive are the rated input and output current, overload capacity, carrier frequency, current limit, and maximum output frequency. Parameter C6-01 must be set to value of "0" for Heavy Duty ratings and "2" for Normal Duty ratings. Factory default is Heavy Duty (C6-01=0).															
*3 Horsepower ratings are based on 230V or 460V NEC Table 430.150.															

Notes:

F7 Programming

This Manual contains descriptions of all user accessible parameters contained in the Drive. Parameters are listed in alpha-numerical order. Parameter number and name, along with a detailed description and its settings are described on the following pages.

A1 Initialization.....	3
A2 User Parameters	5
b1 Sequence.....	6
b2 DC Braking	12
b3 Speed Search	14
b4 Delay Timers.....	18
b5 PID Function	18
b6 Reference Hold (Dwell).....	23
b7 Droop Control	24
b8 Energy Savings Selection.....	25
b9 Zero Servo	26
C1 Accel/Decel	26
C2 S-Curve Acc/Dec.....	29
C3 Motor-Slip Compensation.....	30
C4 Torque Comp.....	31
C5 ASR Tuning.....	32
C6 Carrier Frequency	35
d1 Preset References	37
d2 Reference Limits.....	40
d3 Jump Frequencies	41
d4 Sequence.....	42
d5 Torque Control	43
d6 Field-Weakening.....	49
E1 V/f Pattern	50
E2 Motor Setup.....	56
E3 V/f Pattern 2	58
E4 Motor Setup 2.....	60
F1 PG Option Setup	62
F2 AI-14 Setup.....	65
F3 DI-08, 16 Setup	65
F4 AO-08, 12 Setup.....	66
F5 DO-02, 08 Setup.....	67
F6 Communication Option Selection	68
H1 Digital Inputs.....	69
H2 Digital Outputs.....	87
H3 Analog Inputs	96
H4 Analog Outputs	105
H5 Serial Communications Setup.....	111
H6 Pulse I/O Setup	114

L1 Motor Overload	115
L2 Momentary Power Loss Function	118
L3 Stall Prevention	120
L4 frequency reference Loss Detection	124
L5 Fault Restart	125
L6 Torque Detection	127
L7 Torque Limit	129
L8 Hardware Protection	131
N1 Hunting Prevention	134
N2 AFR Tuning	135
N3 High Slip Braking	135
O1 Monitor Configuration	137
O2 Key Selections	140
O3 Digital Operator Copy Function	145
T1 Auto-Tuning	147
Appendix A - Parameters	151

F7 Basic Programming Parameters

The initialization group contains parameters associated with initial set-up of the Drive. Parameters involving the display language, access levels, initialization and password are located in this group.

◆ A1 Initialization

■ A1-00 Language Selection

Setting	Description
0	English (<i>factory default</i>)
1	Japanese
2	Deutsch
3	Francais
4	Italiano
5	Espanol
6	Portugues

The setting of parameter A1-00 determines which international language the Drive will use to display non-numerical text. The A1-00 parameter will not be changed by an Initialization of the drive (A1-03= “1110: User Initialize”, “2220: 2-Wire Initial”, or “3330: 3-Wire Initial”).

If the Drive is accidentally set to a language unfamiliar to the operator, locating the parameter to change the operator language can be done by performing the following:

1. Press the MENU key until the “-ADV-” MENU is shown in the upper left corner of the digital operator.
2. Press the DATA/ENTER key to enter the programming menu. The first parameter shown is A1-00 (Select Language).
3. Press the DATA/ENTER key again and use the INCREASE and DECREASE arrow keys to choose the preferred language from the list below:

- 0 : English
- 1 : Japanese
- 2 : Deutsch (German)
- 3 : Francais (French)
- 4 : Italiano (Italian)
- 5 : Español (Spanish)
- 6 : Português (Portuguese)

■ A1-01 Access Level Selection

Setting	Description
0	Operation Only
1	User Level
2	Advanced Level (<i>factory default</i>)

A1-01 can be used to allow access to and permission to change all Drive parameters. If the Drive is programmed for Operation Only (A1-01= “0: Operation Only”), then only the Operation and the Programming menus are accessible. Within the Programming menu only parameters A1-01 and A1-04 are adjustable.

If A1-01 is configured for Advanced Access (A1-01= “2: Advanced Level”), then all menus and all parameters are shown. If the Access Level Selection is set to Advanced, all parameters should be adjustable unless:

1. The Drive parameters are password protected (A1-04) which will prevent access to A1-00 through A1-03 and all A2 parameters.
2. A digital input has been configured as a Program Lockout (H1-0X= 1B) is active.
3. During serial communication writing, if a parameter change is also attempted via the digital operator, a “BUSY - WRITE PROTECTED” message will display. Parameter change will not be possible from the digital operator until an Enter command is received via the serial communication to finish the serial writing process.

■ A1-02 Control Method Selection

Setting	Description
0	V/f Control without PG
1	V/f Control with PG
2	Open Loop Vector (<i>factory default</i>)
3	Flux Vector (Closed Loop Vector)

The Control Method of the Drive can be selected in A1-02 to best suit the application.

V/f Control without PG - For general purpose and multiple motor applications.

V/f Control with PG - For general purpose applications requiring closed loop speed control.

Open Loop Vector - For applications requiring precise speed control, quick response, and higher torque at low speeds.

Flux Vector - For applications requiring very precise speed and torque control at wide speed range including zero speed. Uses an encoder feedback.

■ A1-03 Initialize Parameters

Setting	Description
0	No Initialize (<i>factory default</i>)
1110	User Initialize
2220	2-Wire Initialize
3330	3-Wire Initialize

The Drive can be set back to one of three default states via the A1-03 parameter.

1. User Initialization – 1110: The modified Drive parameters are returned to the values selected as user settings. User settings are stored when parameter o2-03= “1: Set Defaults”.
2. 2-Wire Initialization – 2220: The Drive parameters are returned to factory default values with digital inputs S1 and S2 configured as Forward Run and Reverse Run, respectively.
3. 3-Wire Initialization – 3330: The Drive parameters are returned to factory default values with digital inputs S1, S2, and S5 configured as Run, Stop, and Forward/Reverse respectively.

After an initialization is performed, parameter A1-03 will automatically be set back to 0.

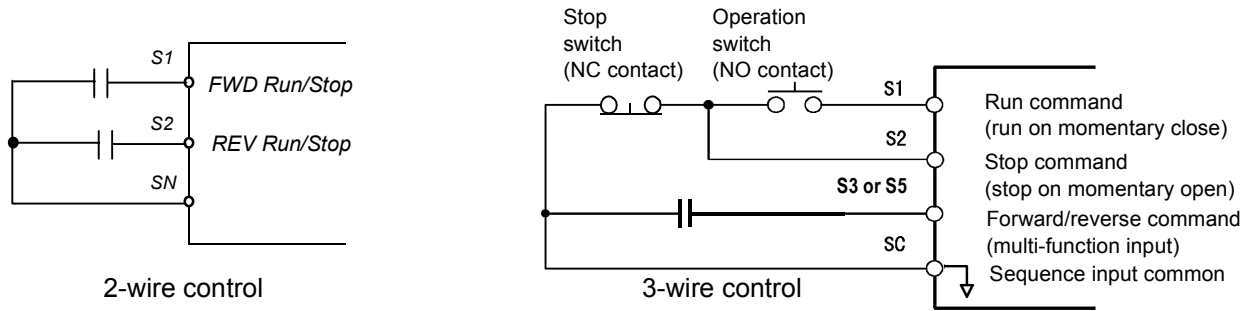

Fig. 1 2 & 3-Wire Control Wiring Examples

IMPORTANT

Some parameters are unaffected by either the 2-Wire or 3-Wire initialization. The following parameters will not be reset when parameter A1-03=2220 or 3330:

A1-00	Language Selection
E1-03	V/f Pattern Selection
o2-04	kVA Selection
o2-09	Initialization Specification Selection

■ **A1-04 Password Entry**

Setting Range: 0 to 9999

Factory Default: 0

If parameters A1-01 through A1-03 and all of the A2 parameters are locked (unchangeable) they can be unlocked by entering the correct password number into A1-04.

Once the correct password number is entered and the specified parameters are unlocked, a 2-Wire or 3-Wire initialization will reset the password to 0000.

■ **A1-05 Select Password**

Setting Range: 0 to 9999

Factory Default: 0

When the value set into A1-04 does NOT match the value set into A1-05, parameters A1-01 thru A1-03 and A2-32 cannot be changed. All other parameters determined by A1-01 can be changed. Parameter A1-05 can be accessed by displaying parameter A1-04, then press and hold the RESET key along with the MENU key simultaneously.

◆ **A2 User Parameters**

■ **A2-01 - A2-32 User Parameter**

Setting Range: b1-01 to o3-02

Factory Default: <none>

The Drive can be programmed to select up to 32 parameters for limited-access programming. By setting the Access Level to User Level (A1-01= “1: User Level”), only the parameters entered into parameters A2-01 through A2-32 can be accessed and modified by the user.

Parameter A1-01 must first be set to 2 (Advanced Access Level) in order to program the A2 parameters to the desired user parameters. Once the A2 parameters are programmed, A1-01 should be set to 1 (User Access Level) to prevent the user from changing any parameters except the A1 parameters and the parameters specified in A2-01 through A2-32.

◆ b1 Sequence

The Sequence Group contains parameters associated with starting and stopping the Drive. Parameters involving the Run Command, Speed Reference location, stopping Method and Hand/Auto changeover are located in this group.

■ b1-01 Frequency Reference Source Selection

Setting	Description
0	Operator - Digital Preset Speed U1-01 or d1-01 to d1-17
1	Terminals (<i>factory default</i>) - Analog Input Terminal A1 (or Terminal A2, see Parameter H3-09)
2	Serial Com - RS-422/485 Terminals R+, R-, S+ and S-
3	Option PCB - Option Board connected at 2CN
4	Pulse Input (Terminal RP)

In order to run the Drive and motor, the Drive must receive a Run command and a frequency reference. Parameter b1-01 specifies from where the frequency reference is received when in the “Remote” mode. Switching into the “Remote” mode can be done by pressing the LOCAL/REMOTE button on the digital operator while the Drive is stopped.

IMPORTANT

If a Run command is input to the Drive but no corresponding frequency reference is input, the Run indicator on the digital operator will turn on and the STOP indicator on the digital operator will blink.

If you want the Drive to follow the frequency reference set by the digital operator: Use the “Local” mode by pressing the LOCAL/REMOTE button or set b1-01= “0: Operator”. The frequency reference can then be entered into the U1-01 monitor parameter in the “-DRIVE-” Menu.

If you want the Drive to follow a “Remote” analog frequency reference: Set b1-01= “1: Terminals”, and connect a 0 – 10 Vdc frequency reference signal between terminals A1 and AC or a 4 – 20 mA frequency reference signal to terminals A2 and AC.

If you want the Drive to receive the frequency reference from serial communication: Set b1-01= “2: Serial Com”, and connect the RS-485/422 serial communications cable to terminals R+, R-, S+, and S- on the control I/O terminal block.

If you want to use the option board to input a frequency reference: Set b1-01= “3: Option PCB”, and plug a communication option board into the 2CN port on the Drive Control PCB. Consult the manual supplied with the option board for instructions on integrating the Drive into the communication system.

IMPORTANT

If b1-01= 3: Option PCB, but an option board is not installed in 2CN, an OPE05 Operator Programming Error will be displayed on the digital operator and the Drive will not run.

If you want the Drive to follow a pulse input frequency reference: Set b1-01= “4: Pulse Input”, and connect the pulse signal to terminal RP.

■ b1-02 Run Command Source Selection

Setting	Description
0	Operator - RUN and STOP keys on the Digital Operator
1	Terminals (<i>factory default</i>) - Terminals S1 or S2
2	Serial Com - Modbus RS-422/485 Terminals R+, R-, S+, and S-
3	Option PCB - Option Board connected on 2CN

To successfully operate the Drive remotely, an external run command must be received by the Drive. Parameter b1-02 specifies from where the run command will be accepted.

Although the Run Source and the Reference Source (b1-01) are normally taken from the same source (e.g. digital operator, terminals or serial communication), this is not always the case.

To issue a run command from the digital operator: Use the “Local” mode by pressing the LOCAL/REMOTE button or set b1-02= “0: Operator”, and use the RUN and STOP key to start and stop the Drive.

To issue the run command from the terminals: Set b1-02= “1: Terminals”, and select between 2-wire and 3-wire control operation by doing the following:

2-Wire Control The factory default setting is for 2-wire operation. In the 2-wire configuration a closure between S1 and SN will be interpreted as a Forward Run command by the Drive. A closure between S2 and SN will be interpreted as a Reverse Run command. If both S1 and S2 are closed, the Drive will stop (decelerate to zero speed) and the digital operator will display an EF (external fault) alarm (Flashing).

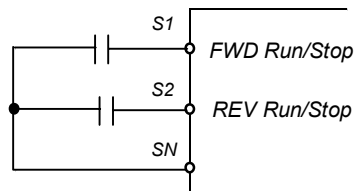

Fig. 2 2-Wire Control

3-Wire Control When any of the multi-function digital input parameters, H1-01 through H1-05, are set to 0, terminals S1 and S2 become Run and Stop, respectively. The multi-function digital input that was set to 0 will function as a Forward/Reverse input for the Drive. When the Forward/Reverse input is open the Drive will run in the Forward direction and when the input is closed, the Drive will run in the Reverse direction.

In 3-wire operation a momentary closure (> 50mS) of S1 will cause the Drive to run provided that S2 is held closed. The Drive will stop any time the S2-SN connection is broken. If the 3-wire configuration is implemented via a 3-wire Initialization (A1-03= “3330: 3-Wire Initial”), then terminal S3 becomes the Forward/Reverse input.

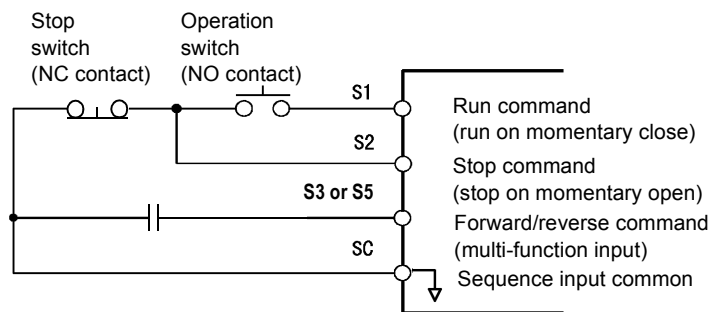

Fig. 3 3-Wire Control

To issue a run command via serial communication: Set b1-02= “2: Serial Com” and connect the RS-485/422 serial communication cable to R+, R-, S+, and S- on the removable terminal block.

To issue the Run command via the communication option board: Set b1-02= “3: Option PCB”, and plug a communication option board into the 2CN port on the Control PCB. Consult the manual supplied with the option board for instructions on integrating the Drive into your communication system.

IMPORTANT

If b1-01= "3: Option PCB" but an option board is not installed in 2CN, an "OPE05" operator programming error will be displayed on the digital operator and the Drive will not run.

■ b1-03 Stopping Method Selection

There are four methods of stopping the Drive when the Run command is removed.

Setting	Description
0	Ramp to Stop (<i>factory default</i>)
1	Coast to Stop
2	DC Injection to Stop
3	Coast w/Timer

“0:Ramp to stop”: When the Run command is removed, the Drive will decelerate the motor to 0 rpm. The rate of deceleration is determined by the active deceleration time. The factory default Decel Time is parameter C1-02.

When the output frequency has dropped below the DC Injection Start Frequency in b2-01 (Default = 0.5HZ) DC current will be injected in the motor at a level determined by b2-02 (50% Default). The DC Injection condition will occur for the time specified by b2-04 (0.0 Default), to establish the end point of the ramp. DC injection can be used to insure the motor is at zero rpm prior to the Drive shutting off.

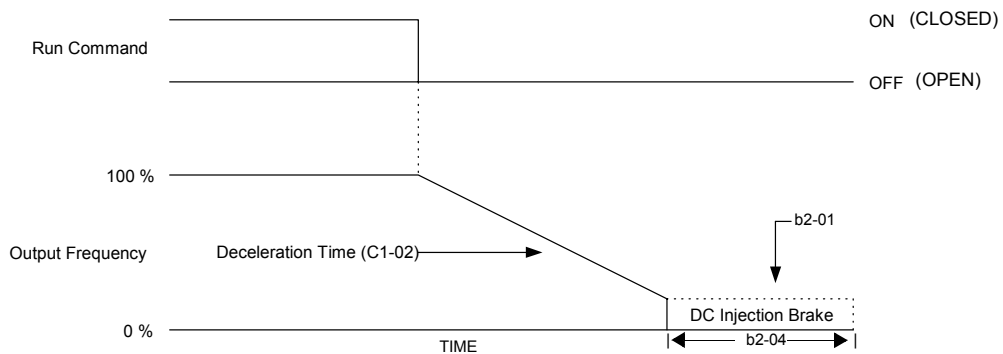

Fig. 4 Deceleration to Stop

The actual deceleration time can be determined by the following formula

$$\text{Time to Stop} = \frac{\text{Output Freq. at time of stop command}}{\text{Maximum Frequency (E1 - 04)}} \times \text{Setting of active Decel Time (C1 - 02, -04, -06 or -08)}$$

If S-Curve characteristics are specified by the Drive programming, they will add to the total time to stop.

“1:Coast to stop”: When the Run command is removed, the Drive will turn off its output and the motor will coast (uncontrolled deceleration). The friction of the driven equipment will eventually overcome any residual inertia of the system and the rotation will stop.

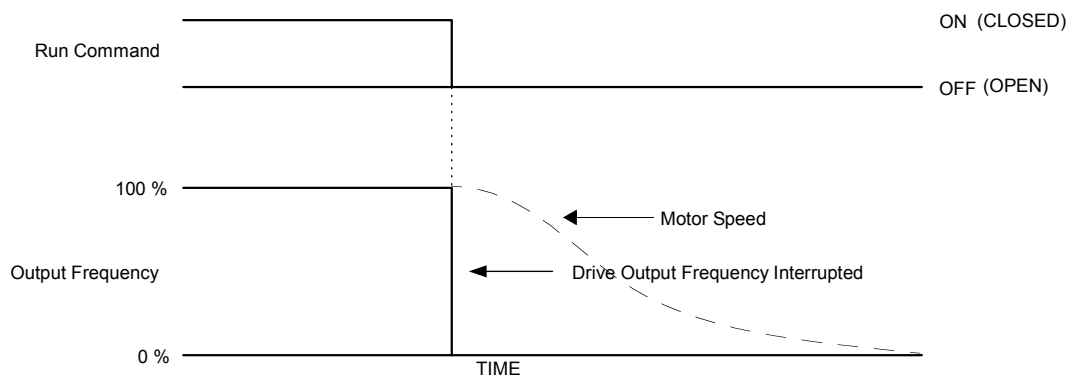

Fig. 5 Coast to Stop

IMPORTANT

After a stop is initiated, a subsequent Run commands input before the Minimum Baseblock Time (L2-03) has expired, will be ignored.

2: DCInj to Stop: When the Run command is removed, the Drive will Baseblock (turn off its output) for the Minimum Baseblock Time (L2-03). Once the Minimum Baseblock Time has expired, the Drive will inject DC current into the motor windings to lock the motor shaft. The stopping time will be reduced as compared to Coast to Stop. The level of DC Injection current is set by parameter b2-02 (50% Default). The DC Injection brake time is determined by the set value in b2-04 and the output frequency at the time the Run command is removed.

$$\text{DC Injection Brake Time} = \frac{(b2 - 04) \times 10 \times \text{Output Frequency}}{\text{Maximum Frequency (E1 - 04)}}$$

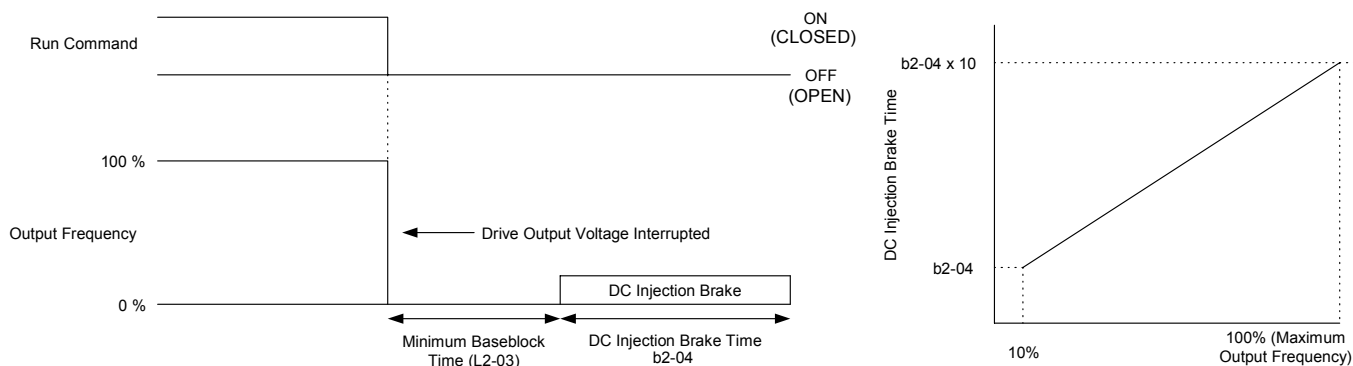

Fig. 6 DC Injection Braking to Stop

IMPORTANT | If an overcurrent (OC) fault occurs during DCInj to Stop, lengthen the Minimum Baseblock Time (L2-03) until the fault no longer occurs.

3: Coast w/Timer: When the Run command is removed, the Drive will turn off its output and the motor will coast to a stop. If a Run command is input before time T (value of C1-02) expires, the Drive will not run and the Run command will need to be cycled before operation can occur. The time T (value of C1-02) is determined by the output frequency when the Run command is removed and the active deceleration time.

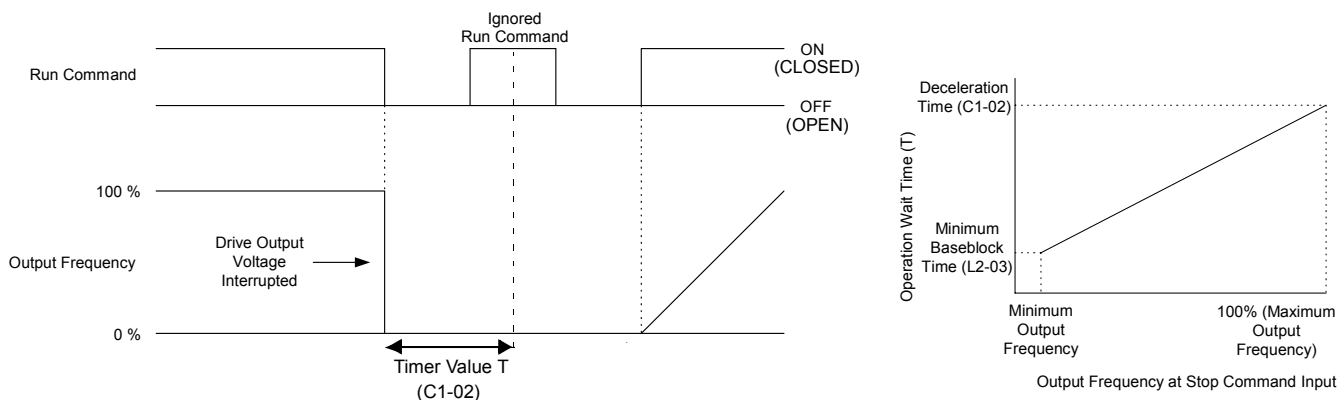

Fig. 7 Coast to Stop with Timer

■ b1-04 Reverse Operation Selection

Setting	Description
0	Reverse Enabled (<i>factory default</i>)
1	Reverse Disabled
2	Exchange Phase

For some applications reverse motor rotation is not applicable and may even cause problems (e.g., air handling units, pumps, etc.). Setting parameter b1-04 to 1 will cause the Drive to ignore any inputs for reverse operation. Setting parameter b1-04 to 2 will change the motor shaft rotation when a Forward Run command is given by exchanging the order of the output phasing.

The factory default setting of parameter b1-04 is “0: Reverse Enabled”. When b1-04= “1: Disabled”, reverse operation is prohibited and no exchanging of output phasing occurs.

■ b1-05 Minimum Output Frequency (E1-09) or Less Operation Selection

Setting	Description
0	Operates According to Frequency Reference (<i>factory default</i>)
1	Output Shuts Off
2	Operates According to E1-09
3	Zero Speed

During flux vector control (A1-02 = 3), select an operation mode to be employed when the frequency reference (analog input) drops below the minimum output frequency (E1-09). During V/f or open loop vector control, Drive output to the motor is shut off (base-block) when the output frequency drops below the minimum output frequency (E1-09).

■ b1-06 Digital Input Scan Time

Setting	Description
0	2ms - For 2 Scans
1	5ms - For 2 Scans (<i>factory default</i>)

This parameter selects the microprocessor scan time for reading multi-function digital inputs (terminals S1 to S8). Set this parameter to “0: 2ms” for quick response and “1: 5ms” for noisy environments.

■ b1-07 Local/Remote Run Selection

Setting	Description
0	Cycle Extern Run (<i>factory default</i>)
1	Accept Extrn Run

When the Drive is switched between the Local mode (the digital operator) to the Remote mode (determined by b1-01 and b1-02), there is the possibility that a Run command is already present (i.e. a switch closure between S1 and SN when b1-02= “1: Terminals”). Parameter b1-07 determines whether the Drive will:

Ignore the external Run command until it is removed and re-instated (b1-07= “0: Cycle Extern Run”)

OR

Accept the already present Run command and immediately begin acceleration to the commanded speed (b1-07= “1: Accept Extrn Run”).

IMPORTANT

When switching from local mode to remote mode when b1-07=1 the Drive may start unexpectedly if the Run command is already applied. Be sure all personnel are clear of rotating machinery and electrical connections prior to switching between local mode and Auto mode.

■ **b1-08 Run Command Selection During Programming**

Setting	Description
0	Disabled (<i>factory default</i>)
1	Enabled

As a safety precaution, the Drive will not normally respond to a Run input when the digital operator is being used to adjust parameters. If it is necessary that external Run commands be recognized even while the Drive is being programmed, set b1-08= “1: Enabled”.

◆ **b2 DC Braking**

The DC Braking Group contains parameters associated with the DC injection braking feature. Parameters involving the starting frequency, current level, braking time, and motor pre-heat current level are located here.

■ **b2-01 DC Injection Braking Start Frequency**

Setting Range: 0.0 to 10.0 Hz

Factory Default: 0.5 Hz

Parameter b2-01 sets the output frequency where the Drive begins DC Injection during ramp to stop in order to lock the rotor of the motor and established the end point of the ramp. If b2-01 < E1-09 (Minimum Frequency), then DC Injection begins at E1-09.

Parameter b2-01 also determines the output frequency that the Drive must be at or below before a Zero Speed condition is considered true. This affects any digital output configured as a Zero Speed signal (H2-0x= “1: Zero Speed”).

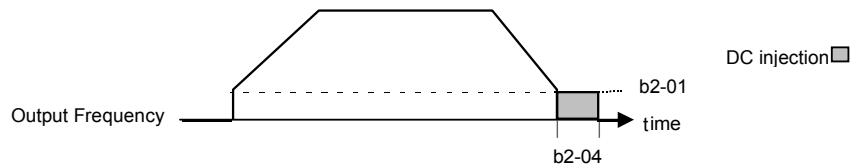

Fig. 8 DC Injection Braking During stopping

■ b2-02 DC Injection Braking Current

Setting Range: 0 to 100%

Factory Default: 50%

The level of DC Injection Braking Current affects the strength of the magnetic field attempting to lock the motor shaft. Increasing the level of current will increase the amount of heat generated by the motor windings and should only be increased to the level necessary to hold the motor shaft. DC Injection current is set in percentage of Drive rated output current. Drive rated output current is stated on the Drive nameplate.

■ b2-03 DC Injection Braking Time at Start

b2-04 DC Injection Braking Time at Stop

Setting Range: 0.00 to 10.00 Seconds

Factory Default: 0.00 Seconds

The Drive can be programmed to automatically DC Inject for a predetermined amount of time prior to accelerating to speed (b2-03) and/or at the end of a Ramp to stop (b2-04). Parameter b2-03 can be used to stop a rotating motor prior to attempting acceleration (i.e. a wind milling fan). If DC Injection braking at start or Speed Search is not enabled, attempting to drive a spinning motor may cause nuisance tripping.

Parameter b2-04 can be used to resist any residual motion of the load after the deceleration has finished.

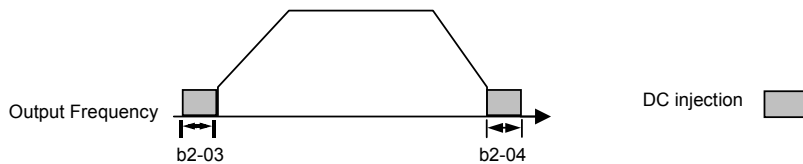

Fig. 9 DC Injection Braking During Starting and stopping

Parameter b2-04 also serves the function of affecting the length of time DC Injection to stop (b1-03= “2: DC Injection to Stop”) will occur.

■ b2-08 Magnetic Flux Compensation Capacity

Setting Range: 0 to 1000%

Factory Default: 0%

This parameter allows the magnetizing motor flux to be boosted when starting the motor. This parameter will facilitate a quick ramp-up of the torque reference and magnetizing current reference to reduce motor slip during start. A setting of 100% equals motor no-load current E2-03. This flux level will be applied below Minimum Output Frequency (E1-09) until the DC Injection Time at Start (b2-03) expires. This parameter is useful when starting motors that are relatively larger than the Drive, due to the requirement for increased magnetizing current. This parameter may also compensate for reduced starting torque due to motor circuit inefficiencies.

◆ b3 Speed Search

The Speed Search function allows the Drive to determine the speed of a motor shaft that is being driven by rotational inertia. Speed Search will allow the Drive to determine the speed of the already rotating motor and begin to ramp the motor to a set speed without first having to bring it to a complete stop. When a momentary loss of supply power is experienced, the Drive output is turned off. This results in a coasting motor. When power returns, the Drive can determine the speed of the coasting motor and start without requiring it to be brought to minimum speed. Speed Search can be programmed to always be active by setting b3-01 or it can be commanded by remote contact closure by setting a digital input.

There are two forms of Speed Search in the Drive, the speed estimation method and the current detection method.

IMPORTANT

When setting the Drive for remote Speed Search input, via a contact closure, the method of Speed Search is determined by the setting of b3-01. If b3-01= "0: SpdsrchF Disable" then the remote input will initiate speed estimation method, and if b3-01= "2: SpdsrchI Disable", then the remote input will start the current detection method.

Parameters L2-03 and L2-04 also affect the current detection method of Speed Search operation.

■ b3-01 Speed Search Selection

Setting	Description
0	Speed Estimation Speed Search Disable
1	Speed Estimation Speed Search Enable
2	Current Detection Speed Search Disable (<i>factory default</i>)
3	Current Detection Speed Search Enable

Speed Estimation: Method (b3-01= 0 or 1) The speed estimation method will calculate the speed using measurements of residual motor fields. The speed estimation version is bi-directional and will determine both the motor speed and direction. To enable speed estimation Speed Search at start, set b3-01= "1: SpdsrchF Enable".

IMPORTANT

If the speed estimation method of Speed Search is to be used, then Auto-tuning must be performed prior to using Speed Search. If the length of cable between the Drive and motor is ever changed after Auto-tuning then Auto-tuning should be performed again.

IMPORTANT

The speed estimation mode cannot be used when there are multiple motors operated by one Drive or the motor is two or more frames smaller than the standard size motor per the Drive capacity.

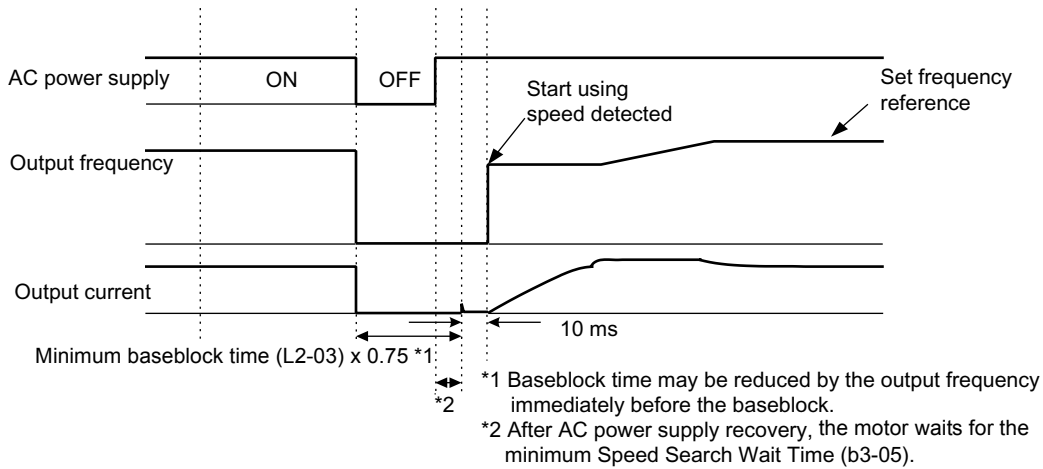

Fig. 10 Speed Search (Estimated Speed Method) after momentary power loss where the power loss time is less than the minimum baseblock time

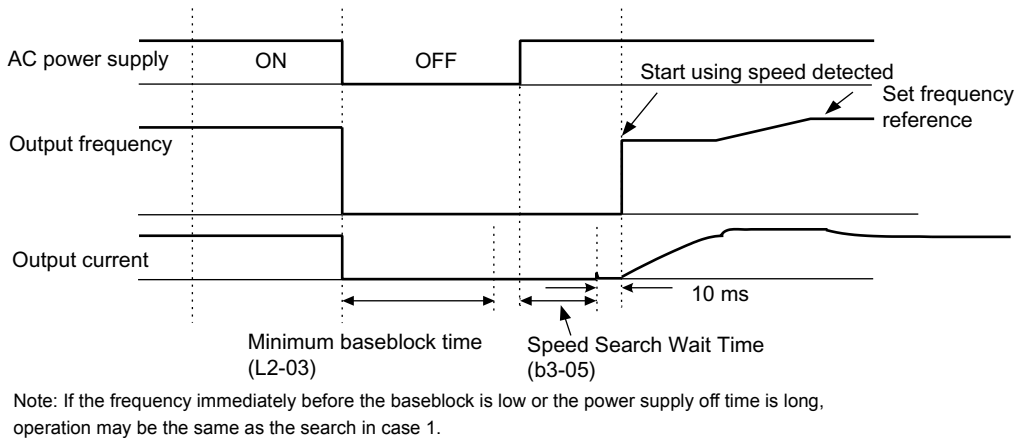

Fig. 11 Speed Search (Estimated Speed Method) after momentary power loss where the power loss time exceeds the minimum baseblock time

Current Detection Method (b3-01=2 or 3): The current detection method starts searching from a predetermined frequency while monitoring the Drive output current to determine when the rotor speed and the Drive output speed (frequency) match. The current detection version is not bi-directional. To enable current detection Speed Search at start set b3-01= “3: SpdsrchI enable” and program any digital input equal to Speed Search 1 (H1-0x= 61) or Speed Search 2 (H1-0x= 62). Speed Search 1 will start searching from the max. frequency (E1-04) and ramp down to meet the rotor speed. Speed Search 2 will start searching from the set frequency and ramp down to meet the rotor speed.

IMPORTANT | If a UV1 fault occurs when current detection Speed Search is attempted, increase the setting of L2-04

IMPORTANT | If an OC fault occurs when Speed Search is attempted after power loss recovery, increase the setting of L2-03.

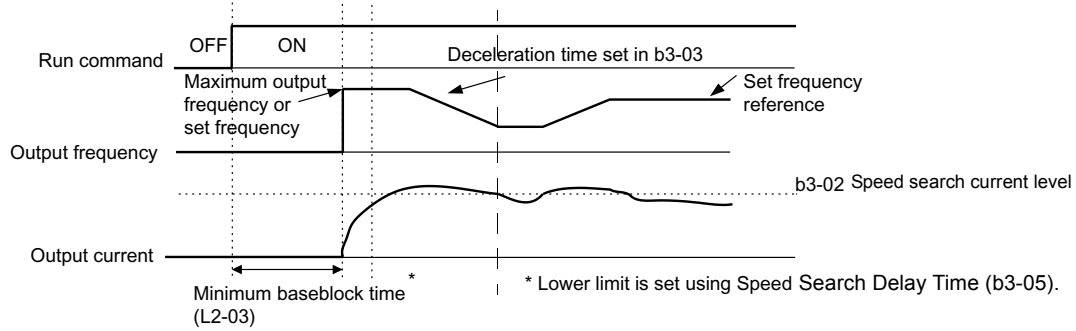

Fig. 12 Speed Search (Current Detection Method) at Startup

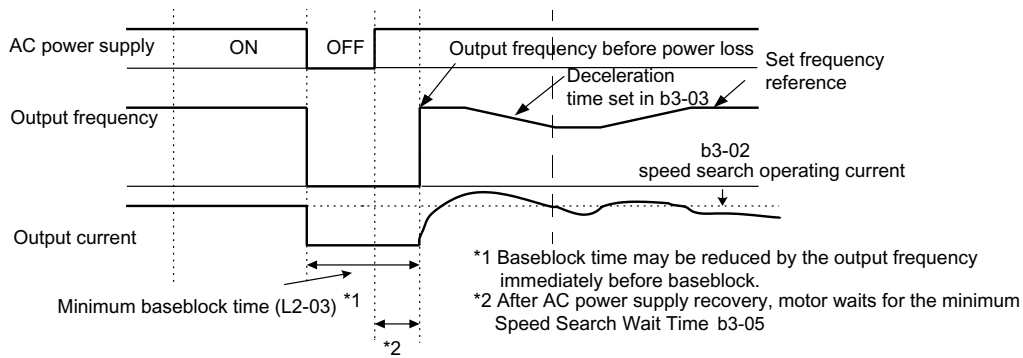

Fig. 13 Speed Search (Current Detection Method) - after momentary power loss where the power loss time is less than the minimum baseblock time

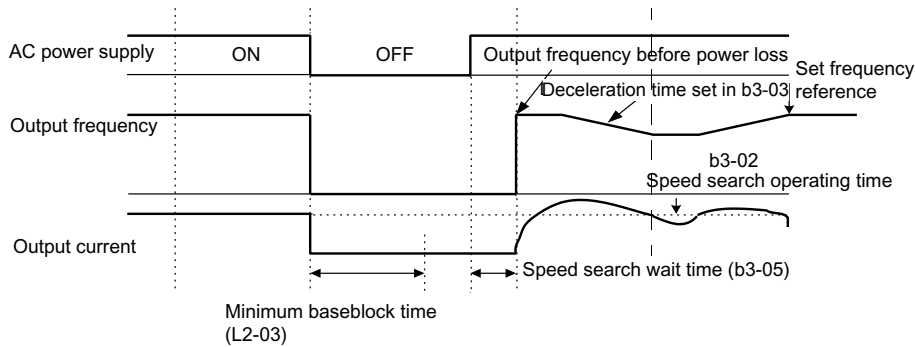

Fig. 14 Speed Search (Current Detection Method) - after momentary power loss where the power loss time exceeds the minimum baseblock time

Setting of b3-01	Automatic Speed Search for all RUN commands and momentary power loss	Speed Search Method Used for Multi-function inputs
0	No	Speed Estimation
1	Yes - Speed Estimation	
2	No	Current Detection
3	Yes - Current Detection	

Note: When parameter A1-02 = 0 (V/f control without PG) or 2 (open loop vector) the factory default setting is 2. When parameter A1-02 = 1 (V/f control with PG) the factory default setting is 3.

■ b3-02 Speed Search Deactivation Current

Setting Range: 0 to 200% of Drive rated output current

Factory Default: 120% of Drive rated output current

When using the current detection method of Speed Search (b3-01 = 2 or 3), parameter b3-02 sets the current level that will determine when the search is complete and the rotor and output speeds match. When the output frequency is higher than the actual rotor speed the slip causes the current to be high. As the output frequency is lowered, the closer it comes to the rotor speed, the lower the current draw will be. When the output current drops below the level as set in b3-02 (100% = Drive Rated Current) the output frequency stops decreasing and normal operation resumes.

Note: When parameter A1-02 = 0 (V/f control without PG) the factory default setting is 120. When parameter A1-02 = 2 (Open Loop Vector) the factory default setting is 100.

■ b3-03 Speed Search Deceleration Time

Setting Range: 0.1 to 10.0 Seconds

Factory Default: 2.0 Seconds

Parameter b3-03 sets the deceleration ramp used by the current detection method of Speed Search (b3-01 = 2 or 3) when searching for the motor's rotor speed. Even if Speed Search 2 is selected, for Speed Search at start, the time entered into b3-03 will be the time to decelerate from maximum frequency (E1-04) to minimum frequency (E1-09).

■ b3-05 Speed Search Delay Time

Setting Range: 0.0 to 20.0 Seconds

Factory Default: 0.2 Seconds

In cases where an output contactor is used between the Drive and the motor, extra waiting time is provided after power returns and before Speed Search is performed. This extra time allows for the contactor to operate. When Speed Search at start is used, b3-05 will serve as the lower limit of the Minimum Baseblock Time (L2-03).

■ b3-10 Speed Search Detection Compensation Gain

Setting Range: 1.00 to 1.20

Factory Default: 1.10

This parameter sets the gain for the frequency reference at which the Drive starts speed estimation speed search. It is used only when b3-01 = 0 or 1.

■ b3-14 Bi-Directional Speed Search Selection

Setting	Description
0	Disabled
1	Enabled (<i>factory default</i>)

The b3-14 parameter can be used to turn off the bi-directional capabilities of the Speed Estimation form of Speed Search. By turning off the bi-directional capability, the speed search will only try to match the speed in the last known direction.

◆ b4 Delay Timers

The Drive has an internal timer function that operates independently from the Drive. A digital input must be programmed to be a timer start input by setting H1-0x= 18. A digital output must be programmed as a timer output by setting H2-0x= 12. (Not to be confused with the “Wait to Run Time” in b1-11)

■ b4-01 Timer Function ON-Delay Time

Setting Range: 0.0 to 3000.0 Seconds

Factory Default: 0.0 Seconds

The timer start input (H1-0x= 18) must be held on for at least the time specified in parameter b4-01 before the digital output programmed as the timer output will close. See Figure below for timing details.

■ b4-02 Timer Function OFF-Delay Time

Setting Range: 0.0 to 3000.0 Seconds

Factory Default: 0.0 Seconds

The timer start input (H1-0x= 18) must be held off for at least the time specified by b4-02 before the digital output programmed as the timer output will open. See Figure below for timing details.

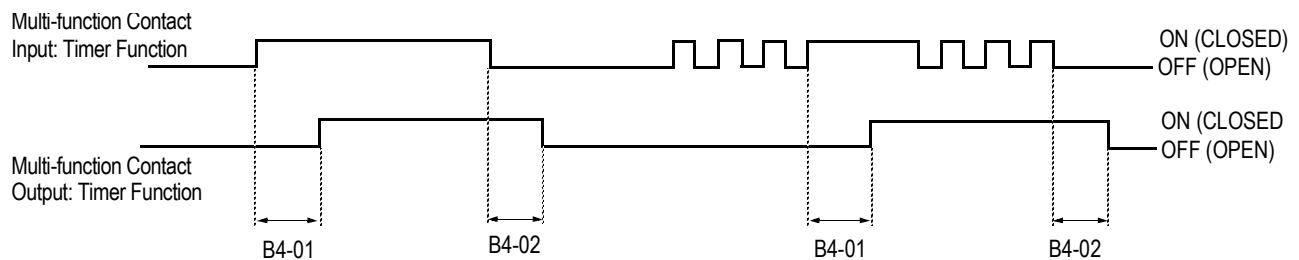

Fig. 15 Timing Diagram of Timer Function

◆ b5 PID Function

The capability to accept an analog signal as feedback for a PID (Proportional + Integral + Derivative) control function is built into the Drive. The PID control function provides closed-loop control and regulation of a system variable such as temperature or pressure. A control signal based on the difference (or proportion) between a feedback signal and a desired setpoint is produced. Integration and derivative calculations are then performed on this signal, based upon the PID parameter settings (B5-01 to B5-19), to minimize deviation, for more precise control.

Proportional - P

PID refers to the type of action used to control modulating equipment such as valves or dampers. With proportional control, a control signal based on the difference between an actual condition and a desired condition is produced. The difference, such as that between an actual temperature and setpoint is the “error”. The inverter adjusts its output signal related directly to the error magnitude.

Integral - I

The integral action is designed to minimize offset. An integrating term is used to observe how long the error condition has existed, summing the error over time. Once the system has stabilized, the offset would be minimized.

Derivative - D

Overshoot refers to a control loop tendency to overcompensate for an error condition, causing a new error in the opposite direction. Derivative action provides an anticipatory function that exerts a “braking” action on the control loop. When combined, the proportional integral, and derivative actions provide quick response to error, close adherence to the setpoint, and control stability.

The analog feedback to the Drive for the PID control is via the A2 or A3 terminal. Set parameter H3-09 or H3-05 to “B: PID Feedback” to use terminal A2 or A3, respectively, as feedback for the PID functionality of the Drive. To use the analog input terminal A2 or A3 as the PID setpoint, set parameter H3-09 or H3-05 to “C: PID Setpoint,” respectively. The PID setpoint can be configured to come from one of many different inputs or parameters. The table below describes the options for originating the PID setpoint.

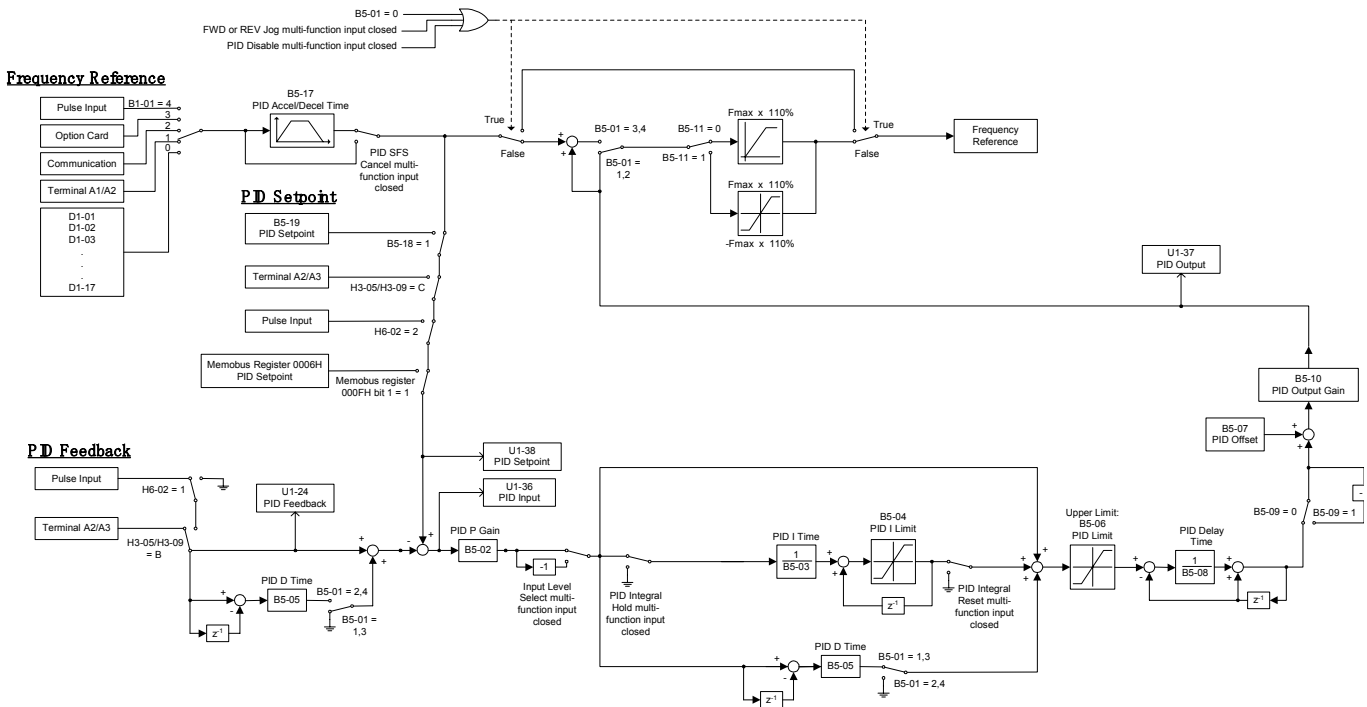

Fig. 16 PID Block Diagram

■ b5-01 PID Function Setting

Setting	Description
0	Disabled (<i>factory default</i>)
1	D = Feedback
2	D = Feed-Forward
3	Frequency Reference + PID Output (D = Feedback)
4	Frequency Reference +PID Output (D = Feed-Forward)

The Drive can be used as a stand-alone PID controller. If PID functionality is selected by parameter b5-01, the Drive will adjust its output to cause the feedback from a transmitter to match the PID setpoint (b5-19). To enable PID control, set b5-01 to 1, 2, 3, or 4 according to the application.

■ b5-02 Proportional Gain Setting

Setting Range: 0.00 to 25.00

Factory Default: 2.00

The proportional gain will apply a straight multiplier to the calculated difference (error) between the PID Setpoint and the measured transmitter feedback at terminal A2. A large value will tend to reduce the error but may cause instability (oscillations) if too high. A small value may allow too much offset between the setpoint and feedback (See Figure below).

■ b5-03 Integral Time Setting

Setting Range: 0.0 to 360.0 Seconds

Factory Default: 5.0 Seconds

The Integral factor of PID functionality is a time-based gain that can be used to eliminate the error (difference between the setpoint and feedback at steady state). The smaller the Integral Time set into b5-03, the more aggressive the Integral factor will be. To turn off the Integral Time, set b5-03= 0.00.

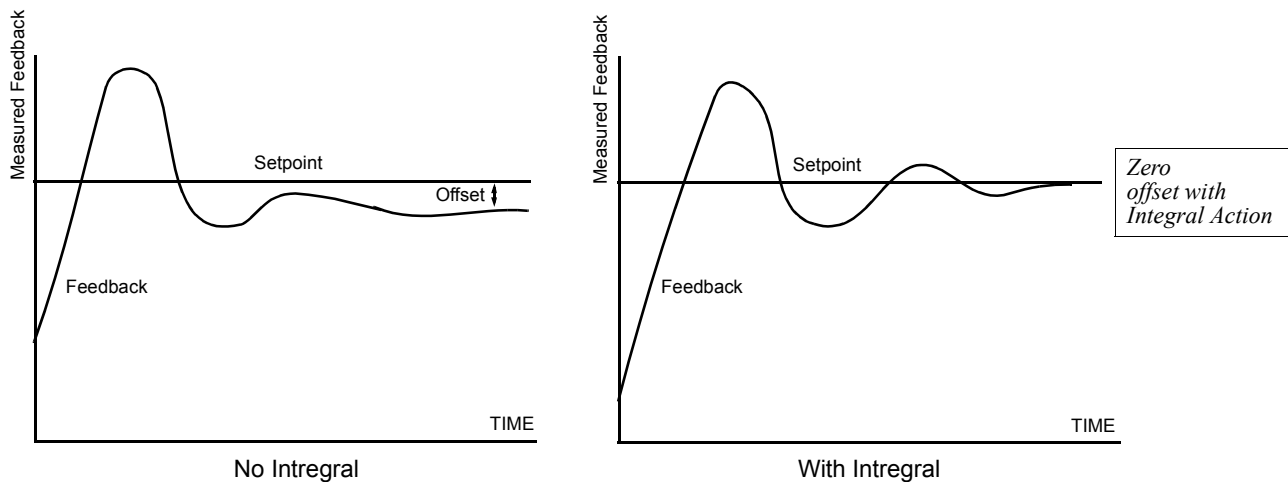

Fig. 17 PID Feedback Response Characteristics

■ b5-04 Integral Limit Setting

Setting Range: 0.0 to 100.0%

Factory Default: 100.0%

On some applications, especially those with rapidly varying loads, the output of the PID function may have large oscillations. To suppress these oscillations, a limit can be applied to the integrate factor by programming b5-04.

■ b5-05 Derivative Time Setting

Setting Range: 0.00 to 10.00 Seconds

Factory Default: 100.0%

The derivative calculation attempts to control the remaining overshoot left over after the proportion and integral calculations. If the system is approaching the intended value very rapidly, the derivative control produces a strong braking action to prevent overshoot. If the system is already stable with very little deviation change, derivative control has very little effect. The derivative time is used to dampen oscillations and reduce overshoot, thus improving stability. Setting the derivative time to a larger number produces more braking action in the control system. A setting of 0.00 disables derivative control.

■ b5-06 PID Output Limit

Setting Range: 0.0 to 100.0%

Factory Default: 100.0%

Places a cap on the output of the PID function. Limiting the PID function may help to prevent large overshoots in the Drive's response to error (the difference between the setpoint and the feedback).

■ b5-07 PID Offset Adjustment

Setting Range: -100.0% to +100.0%

Factory Default: 0.0%

The PID Offset Adjustment parameter has two different uses. Parameter b5-07 serves different functions depending on whether it is used on a standard PID loop or a Differential PID loop.

Parameter b5-07 causes an offset to be applied to the output of the PID function in a non-Differential PID loop. Every time the PID output is updated, the offset (b5-07) is summed with the PID output. This can be used to artificially kick-start a slow starting PID loop.

If the Drive is configured for Differential PID Regulation (H3-09= "16: PID Differential"), then this parameter is the targeted setpoint for the maintained differential between the signal measured on analog input A1 and the signal measured on analog input A2.

■ b5-08 PID Primary Delay Time Constant

Setting Range: 0.00 to 10.00 Seconds

Factory Default: 0.00 Seconds

Acts as a time based filter that lowers the responsiveness of the PID function, but also makes the function more stable when the setpoint varies rapidly or when the feedback is noisy.

■ b5-09 PID Output Level Selection

Setting	Description
0	Normal Output (direct acting) (<i>factory default</i>)
1	Reverse Output (reverse acting)

Normally, the output of the PID function causes an increase in motor speed whenever the measured feedback is below the setpoint. This is referred to as direct acting response. However, if b5-09= "1: Reverse Output", the output of the PID function causes the motor to slow down when the feedback is below the setpoint. This is referred to as reverse acting response.

■ b5-10 PID Output Gain Setting

Setting Range: 0.0 to 25.0

Factory Default: 1.0

Applies a multiplier to the output of the PID function. Using the gain can be helpful when the PID function is used to trim the frequency reference. Increasing b5-10 causes the PID function to have a greater regulating affect on the frequency reference.

■ b5-11 PID Reverse Selection

Setting	Description
0	0 Limit (<i>factory default</i>)
1	Reverse

Parameter b5-11 determines whether reverse operation is allowed while using PID control (b5-01≠0) and the PID output goes negative. The factory default setting will not allow the Drive to run in reverse when the PID output goes negative. Zero speed limit is automatic when reverse prohibit is selected using b1-04. (Refer also to b5-09).

■ b5-12 PID Feedback Reference Missing Detection Selection

Setting	Description
0	Disabled (<i>factory default</i>)
1	Alarm
3	Fault

■ b5-13 PID Feedback Loss Detection Level

Setting Range: 0 to 100%
 Factory Default: 0%

■ b5-14 PID Feedback Loss Detection Time

Setting Range: 0.0 to 25.0 Seconds
 Factory Default: 1.0 Seconds

Loss of feedback can cause problems to a PID application. The Drive can be programmed to turn on a digital output whenever a loss of feedback occurs. Feedback Loss Detection is turned on by b5-12. When b5-12= “1: Alarm”, the Drive acknowledges the loss of feedback without stopping or turning on the fault output (MA-MB). If b5-12= “2: Fault”, the Drive coasts to a stop and turns on the fault output if the feedback is determined to be lost. The Drive interprets feedback loss whenever the feedback signal drops below the value of b5-13 and stays below that level for at least the time set into b5-14. See Figure below for timing details.

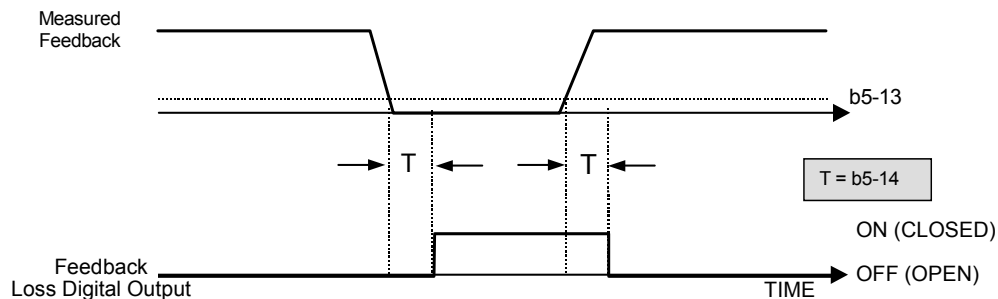

Fig. 18 Loss of PID Feedback Feature

■ b5-15 Sleep Function Start Level

Setting Range: 0.0 to 200.0 Hz
 Factory Default: 0.0 Hz

■ b5-16 Sleep Delay Time

Setting Range: 0.0 to 25.5 Seconds
 Factory Default: 0.0 Seconds

■ b5-17 PID Accel/Decel Time

Setting Range: 0.0 to 25.5 Seconds
 Factory Default: 0.0 Seconds

This is a soft start function that is applied to the PID setpoint analog input. Instead of having nearly instantaneous changes in signal levels, there is a programmed ramp applied to level changes. When changing setpoints the error can be limited by gradually ramping the setpoint through the use of parameter b5-17.

■ b5-18 PID Setpoint Selection

Setting	Description
0	Disabled (<i>factory default</i>)
1	Enabled

In order to use parameter b5-19 as the PID Setpoint, set parameter b5-18= “1: Enabled”. If b5-18= “0: Disabled” the PID Setpoint will either be:

- Modbus Register 06H (If Register 0FH bit 1 is high)
- The active frequency reference (i.e. Determined by the setting of b1-01). See Table 1 “Setpoint Options”

■ b5-19 PID Setpoint Value

Setting Range: 0.00 to 100.00%
 Factory Default: 0.00%

Parameter b5-19 is for a PID Setpoint value. When b5-18= “1: Enabled”, the value of b5-19 will take precedent over any other PID setpoint unless the Drive is set up for Differential Feedback, in which case, b5-18 and b5-19 have no affect on the PID function.

◆ b6 Reference Hold (Dwell)

The reference hold or dwell function is used to temporarily hold the output frequency at a set reference, for a set time, and then continue to ramp up. This function can be used when driving a permanent magnet motor, or a motor with a heavy starting load. This pause in acceleration allows the magnets in a permanent magnet motor to synchronize with the stator field of the motor, thus reducing traditionally high starting current.

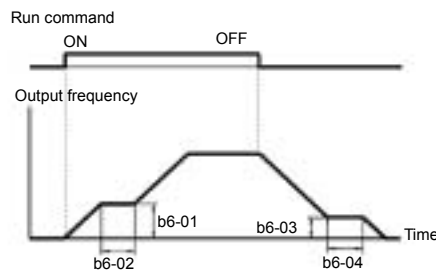

Fig. 19 Loss of PID Feedback Feature

■ **b6-01 Dwell Reference at Start**

Setting Range: 0.0 to 400.0 Hz

Factory Default:0.0 Hz

Sets the dwell frequency reference during acceleration in units of 0.1 Hz.

■ **b6-02 Dwell Time at Start**

Setting Range: 0.0 to 10.0 Seconds

Factory Default:0.0 Seconds

Sets the amount of time that the frequency reference dwells during acceleration in units of 0.1 seconds.

■ **b6-03 Dwell Reference at Stop**

Setting Range: 0.0 to 400.0 Hz

Factory Default:0.0 Hz

Sets the dwell frequency reference during deceleration in units of 0.1 Hz.

■ **b6-04 Dwell Time at Stop**

Setting Range: 0.0 to 10.0 Seconds

Factory Default:0.0 Seconds

Sets the amount of time that the frequency reference dwells during deceleration in units of 0.1 seconds.

◆ **b7 Droop Control**

The droop control function reduces the motor speed based on the load torque of the motor.

■ **b7-01 Droop Control Level**

Setting Range: 0.0 to 100.0%

Factory Default:0.0%

Sets the amount of speed reduction as a percentage of maximum output frequency E1-04 when the motor is producing 100% of rated torque. The actual amount of motor speed reduction is based on the ratio of the amount of motor torque and the maximum output frequency E1-04.

■ **b7-02 Droop Control Delay Time**

Setting Range: 0.03 to 2.00 Seconds

Factory Default:0.05 Seconds

Sets the response time in response to load changes. Decreasing this setting will cause the response to become quicker; however, instability may occur.

◆ b8 Energy Savings

The energy savings function improves overall system operating efficiency by operating the motor at its highest efficiency. This is accomplished by continuously monitoring the motor load and adjusting the motor terminal voltage so that the motor always operates near its rated slip frequency. A motor is most efficient when operating near rated slip conditions.

■ b8-01 Energy Savings Selection

Setting	Description
0	Disabled (<i>factory default</i>)
1	Enabled

When the Energy Savings function is enabled (b8-01= “1: Enabled”), the Drive reduces the output voltage to the motor below the voltage value specified by the programmed V/f pattern whenever the motor load is light. Since torque is reduced during this voltage reduction, the voltage has to return to normal levels once the load returns. The energy savings is realized through improved motor efficiency. The reduced output voltage causes increased rotor slipping even with a light load. A motor is most efficient when operating fully loaded (i.e. operating at rated slip).

■ b8-02 Energy Saving Control Gain

Setting Range: 0.0 to 10.0
Factory Default: 1.0

The output voltage during energy saving operation is the product of the normal V/f settings (E1-03 to E1-13) and the energy saving gain. The output voltage decreases and recovers according to the energy saving control filter time constant b8-03. As the energy saving gain increases, the output voltage increases also.

Note: When parameter A1-02 = 2 (Open Loop Vector) the factory default setting is 0.7. When parameter A1-02 = 3 (Flux Vector) the factory default setting is 1.0.

■ b8-03 Energy Saving Control Filter Time Constant

Setting Range: 0.00 to 10.00
Factory Default: Model Dependent

Parameter b8-03 sets the response time of the energy saving function. Decreasing this setting will cause the response to become quicker; however, instability may occur if it is decreased too much.

Note: For Drive models F7U2055 to 2100 and F7U4055 to 4300 the factory default setting is 2.00 when parameter A1-02 = 2 (Open Loop Vector) and 0.05 when parameter A1-02 = 3 (Flux Vector). For all other Drive models the factory default setting is 0.50 when parameter A1-02 = 2 (Open Loop Vector) and 0.01 when parameter A1-02 = 3 (Flux Vector).

■ b8-04 Energy Saving Coefficient Value

Setting Range: 0.0 to 655.0
Factory Default: Model Dependent

Parameter b8-04 is used in maximizing motor efficiency. The factory setting will be Drive capacity dependant but can be adjusted in small amounts while viewing the kW monitor (U1-08) and running the Drive to minimize the output kW. A larger value typically results in less voltage to the motor and less energy consumption. Too large a value will cause the motor to stall.

■ b8-05 Power Detection Filter Time

Setting Range: 0 to 2000 ms

Factory Default: 20 ms

The Energy Saving function will search out the lowest output voltage in order to achieve minimum output power usage. Parameter b8-05 determines how often the output power (kW) is measured and the output voltage is adjusted.

■ b8-06 Search Operation Voltage Limit

Setting Range: 0 to 100 %

Factory Default: 0%

Once Energy Savings is enabled and the optimal energy saving coefficient value has been set, the programmer can have the Drive further search out the proper voltage to achieve the lowest output power by making minute changes to the output voltage and measuring the output power every b8-05 ms. Parameter b8-06 sets limits to the range over which the voltage will be adjusted in order to minimize the power output. Settings too large a value may allow the motor to stall if the load is applied abruptly.

If b8-06= 0, then the optimum voltage search operation is disabled (but not Energy Savings itself).

◆ b9 Zero Servo

The zero servo function is enabled when the multi-function contact input is set to zero servo command (H1-0x = “72”). The motor position is then memorized when motor speed feedback is less than the zero speed level (B2-01).

■ b9-01 Zero Servo Gain

Setting Range: 0 to 100

Factory Default: 5

Sets the zero-servo position loop gain. When adjusting the gain, the higher the setting, the quicker the response. However, if the gain is set too high, it can cause overshoot and a possible runaway condition.

■ b9-02 Zero Servo Completion Width

Setting Range: 0 to 16383 Pulses

Factory Default: 10 Pulses

The function of b9-02 is to set the number of pulses used for the multi-function contact output (H2-0x = “33”). During zero servo, the multi-function output will be closed until the number set into b9-02 has been completed. After the number of pulses has been completed, the multi-function output changes to the open state.

◆ C1 Acceleration/Deceleration

■ C1-01 Acceleration Time 1

C1-02 Deceleration Time 1

C1-03 Acceleration Time 2

C1-04 Deceleration Time 2

C1-05 Acceleration Time 3

C1-06 Deceleration Time 3

C1-07 Acceleration Time 4

C1-08 Deceleration Time 4

Setting Range: 0.0 to 6000.0 Seconds

Factory Default: 10.0 Seconds

Note: Setting range may be 0.00 to 600.00 or 0.0 to 6000.0 depending on the setting of parameter C1-10.

Acceleration time sets the time necessary for the output frequency to accelerate from 0Hz to maximum output frequency (E1-04). Deceleration time sets the time necessary for the output frequency to decelerate from the maximum output frequency (E1-04) to 0Hz.

C1-01 and C1-02 are the factory default active accel/decel “pair”. Other accel/decel pairs (C1-03 to C1-08) exist that can be activated by a multi-function digital input (H1-0x = 7 and 1A). Alternatively, the active accel/decel pair can be switched from accel/decel pair 1 (C1-01 and C1-02) to accel/decel pair 4 (C1-07 and C1-08) by a switch over frequency as programmed in parameter C1-11.

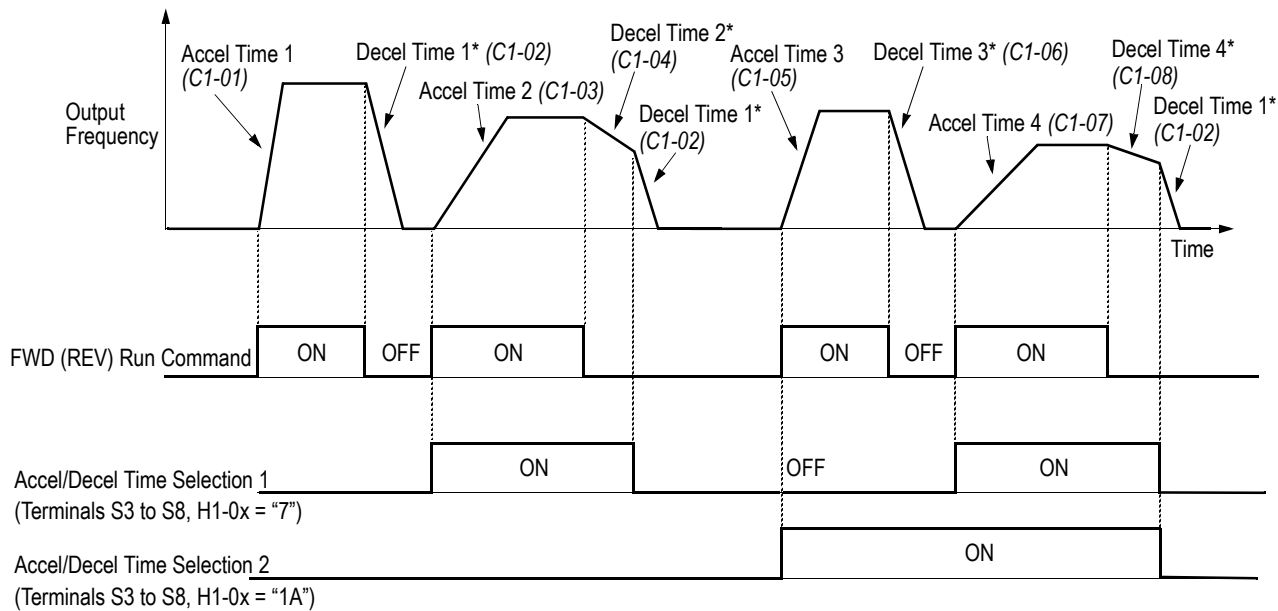

* When “deceleration to stop” is selected (B1-03 = “0”)

Fig. 20 Timing Diagram of Accel / Decel Time Change

When any of the multi-function contact input selections (H1-01 to H1-06) are set to “7” and “1A”, up to four accel/decel times can then be selected by opening or closing the appropriate accel/decel time selection commands (terminals 3 to 8).

Accel/decel Time Selection 1 Multi-function Input Setting = “7”	Accel/decel Time Selection 2 Multi-function Input Setting = “1A”	Accel Time	Decel Time
Open or not set	Open or not set	C1-01	C1-02
Closed	Open or not set	C1-03	C1-04
Open or not set	Closed	C1-05	C1-06
Closed	Closed	C1-07	C1-08

■ C1-09 Fast Stop Time

Setting Range: 0.0 to 6000.0 Seconds

Factory Default: 10.0 Seconds

A special deceleration parameter is available for use with emergency or fault operations. Parameter C1-09 will set a special deceleration that can be operated by closing a digital input configured as H1-0x= 15 or H1-0x= 17. A digital input configured as H1-0x= 15 will look for a switch closure before initiating the Fast Stop operation. A digital input configured as H1-0x= 17 will look for the switch opening before initiating the Fast Stop operation.

Unlike a standard deceleration time, once the Fast Stop operation is initiated even momentarily, the Drive cannot be re-operated until the deceleration is complete, the Fast Stop input is cleared, and the Run command is cycled.

■ C1-10 Accel / Decel Time Setting Unit

Setting	Description
0	0.01 sec - Accel/decel time (C1-01 to C1-09) setting range is in units of 0.01 second. Accel/decel time setting range: 0.00 to 600.00 sec).
1	0.1 sec (<i>factory default</i>) - Accel/decel time (C1-01 to C1-09) setting range is in units of 0.1 second. Accel/decel time setting range: 0.0 to 6000.0sec.

If any of the parameters C1-01 to C1-09 are set to 600.1 seconds or more, C1-10 cannot be set to 0.

■ C1-11 Accel/Decel Switch Frequency

Setting Range: 0.0 to 200.0 Hz

Factory Default: 0.0 Hz

The Drive can be programmed to automatically switch between the two sets of Accel/Decel parameters on the fly. No digital input is required. If parameter C1-11 is set to a frequency other than zero, the Drive will use Acceleration 1 and Deceleration 1 whenever the output frequency is equal to or above the value of C1-11 and use Acceleration 4 and Deceleration 4 whenever the output frequency is below the value of C1-11.

A multi-function input programmed as “Multi-Acc/Dec 1” and “Multi-Accel/Dec 2” will have priority over C1-11. For example, if the output frequency is greater than the value of C1-11 but a digital input configured as “Multi-Acc/Dec 1” is closed then Acceleration 2 and Deceleration 2 are active.

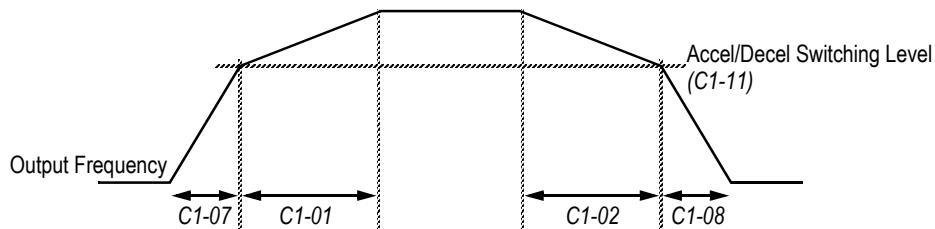

Fig. 21 Accel/Decel Switch Frequency Operation

◆ C2 S-Curve Accel / Decel

- C2-01 S-Curve Characteristic at Accel Start
- C2-02 S-Curve Characteristic at Accel End
- C2-03 S-Curve Characteristic at Decel Start

Setting Range:0.00 to 2.50 Seconds

Factory Default:0.20 Seconds

C2-02 S-Curve Characteristic at Decel End

Setting Range:0.00 to 2.50 Seconds

Factory Default:0.00 Seconds

Parameters C2-01 and C2-02 will affect the acceleration rate of the output frequency in order to reduce shock to the load. The S-curve addition to the acceleration profile can ramp the acceleration rate from a 0 to the rate specified by the active Acceleration Time (C1-01,C1-03, C1-05, or C1-07) and back to 0.

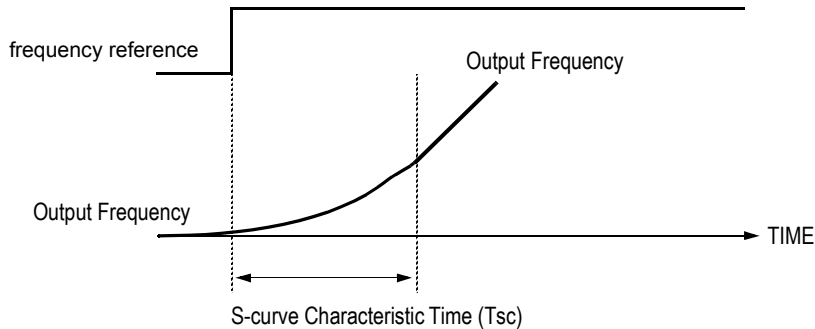

Fig. 22 S-curve Characteristic Timing Diagram

The S-Curve transition into and out of the active acceleration rate can be programmed independently. C2-01 will ramp up the acceleration from no acceleration up to the rate of C1-01 or active acceleration time. C2-02 will ramp the acceleration rate from the rate of C1-01 or active deceleration time back down to no acceleration (constant speed). The use of S-Curve characteristics will lengthen the overall acceleration time as follows:

$$\text{Overall Acceleration Time} = \text{Active Acceleration Time} + \frac{(C2 - 01) + (C2 - 02)}{2}$$

The following figure shows FWD/REV run switching during deceleration to stop.

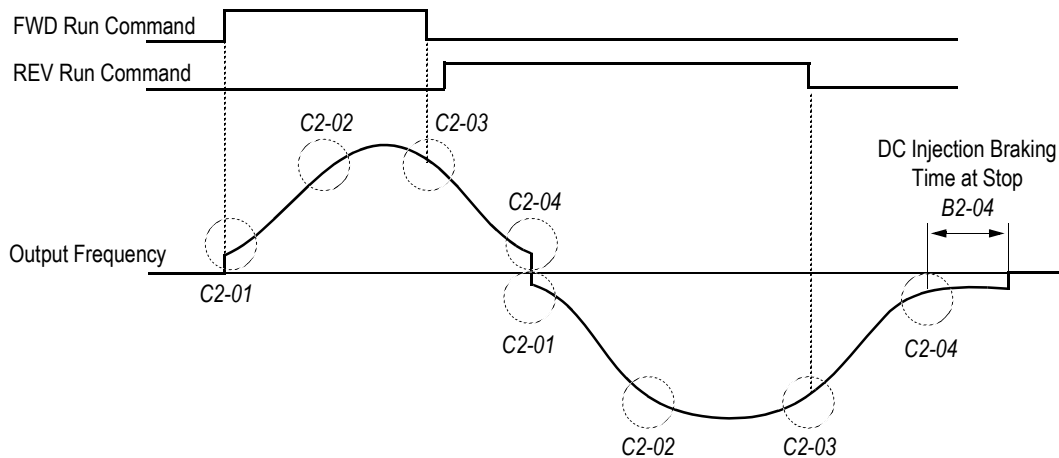

Fig. 23 S-Curve Timing Diagram - FWD / REV Operation

◆ C3 Motor-Slip Compensation

As the load becomes larger, the motor speed is reduced and motor slip increases. The slip compensation function keeps the motor speed constant even under varying load conditions.

■ C3-01 Slip Compensation Gain

Setting Range: 0.0 to 2.5
Factory Default: 1.0

This function controls the output frequency in response to the load's torque demand. Increase the set value in one tenth (0.1) increments when operating at low speeds; decrease the set value as the motor speed increases.

During flux vector control, this gain compensates for motor slip causes by changes in temperature. Normally, this setting does not have to be modified.

Note: Default factory setting will be 0.0 when parameter A1-02=0 (V/f control without PG). When parameter A1-02=2 (Open Loop Vector) or 3 (Flux Vector) the default factory setting will be 1.0.

■ C3-02 Slip Compensation Primary Delay Time

Setting Range: 0 to 10000 ms
Factory Default: 200 ms

Adjust the slip compensation delay time when motor speed is unstable or speed response is slow. Increase the set value in 10ms increments when operating at low speeds; decrease the set value as the motor speed increases.

Note: Default factory setting will be 2000 ms when parameter A1-02=0 (V/f control without PG). When parameter A1-02=2 (Open Loop Vector) the default factory setting will be 200 ms.

■ C3-03 Slip Compensation Limit

Setting Range: 0 to 250%
Factory Default: 200%

Sets the slip compensation limit as a percentage of motor rated slip (E2-02).

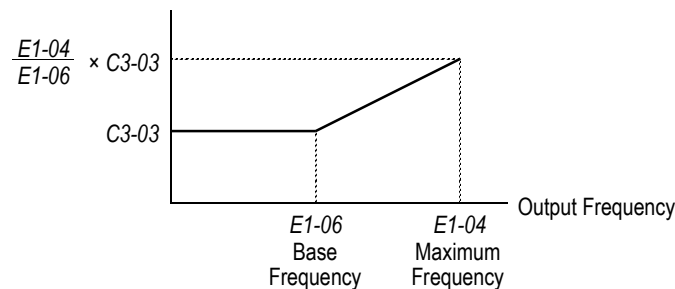

Fig. 24 Slip Compensation Limit Adjustment

■ C3-04 Slip Compensation Selection During Regeneration

Setting	Description
0	Disabled (<i>factory default</i>)
1	Enabled

Determines whether slip compensation is enabled or disabled during regenerative operation.

■ C3-05 Output Voltage Limit Operation Selection

Setting	Description
0	Disabled (<i>factory default</i>)
1	Enabled

Determines if the motor flux is automatically decreased when output voltage saturation occurs in the constant horsepower region.

◆ C4 Torque Compensation

■ C4-01 Torque Compensation Gain

Setting Range: 0.00 to 2.50
Factory Default: 1.00

■ C4-02 Torque Compensation Primary Delay Time

Setting Range: 0 to 10000 ms
Factory Default: 200 ms

The Torque Compensation function compensates for insufficient torque production at start-up and during low speed operation. The Drive will detect increases in the motor load by monitoring the output current and compensate by increasing the output voltage. The increased output voltage leads to an increase in usable torque.

Parameter C4-01 sets the aggressiveness of the compensation for IR (resistive) and IL (inductive) losses in the motor windings, which are more pronounced at lower speeds. Normally C4-01 does not need to be changed but may require adjustment in the following cases:

- If the Drive to motor cable is long, increase C4-01
- If the motor capacity is smaller than the Drive capacity, increase C4-01
- If the low speed motor performance is unstable, decrease C4-01.
- If the output current level exceeds the Drive's rated current while operating at low speeds, increase C4-01

Parameter C4-02 determines how quickly the Torque Compensation function will react to situations of insufficient torque. Again, C4-02 will not normally require adjustment except for the following situations:

- If the motor vibrates, increase C4-02
- If the motor response is sluggish (and possibly stalls), decrease C4-02

Note: Default factory setting will be 200 ms when parameter A1-02=0 (V/f control without PG) or 1 (V/f control with PG). When parameter A1-02=2 (Open Loop Vector) the default factory setting will be 20 ms.

IMPORTANT | Performing Auto-tuning can enhance low speed performance.

■ C4-03 Torque Compensation at Forward Start

Setting Range: 0.0 to 200.0 %
 Factory Default: 0.0 %

This parameter may improve the motor performance during start. This feature functions only when starting a motor in the forward direction. Torque reference and motor flux can be ramped up quickly to improve speed response during start. A setting of 0.0 disables this feature.

■ C4-04 Torque Compensation at Reverse Start

Setting Range: -200.0 to 0.0 %
 Factory Default: 0.0 %

This parameter may improve the motor performance during start. This feature functions only when starting a motor in the reverse direction. Torque reference and motor flux can be ramped up quickly to improve speed response during start. A setting of 0.0 disables this feature.

■ C4-05 Torque Compensation Time Constant

Setting Range: 0 to 200 ms
 Factory Default: 10 ms

This parameter functions with C4-03 and C4-04. This parameter is the time delay that will be applied to the Torque Compensation parameters C4-03 and C4-04. A setting of less than 4 milliseconds (ms) causes this filter to be disabled.

◆ C5 ASR Tuning

The automatic speed regulator (ASR) provides optimum performance during changes in motor speed or load, when speed feedback is provided.

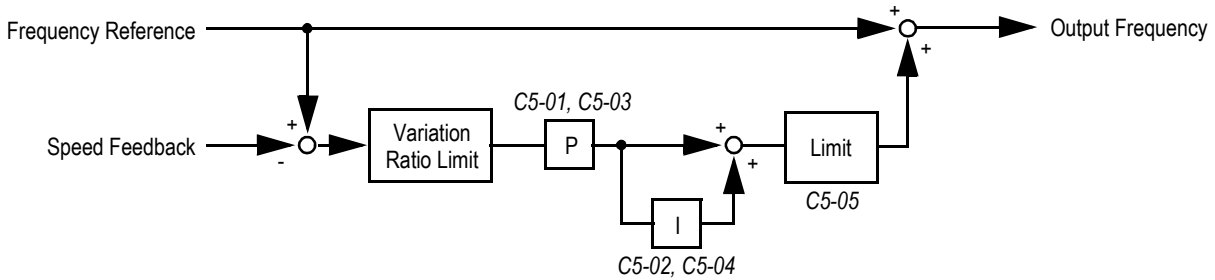

Fig. 25 ASR Block Diagram (V/f Control with PG)

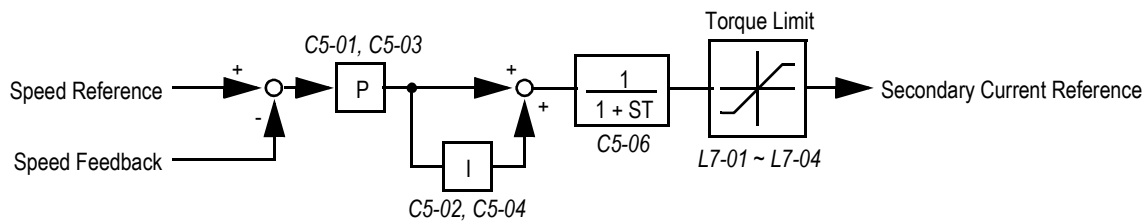

Fig. 26 ASR Block Diagram (Flux Vector Control)

■ C5-01 ASR Proportional Gain 1

Setting Range: 1.00 to 300.0
Factory Default: 20.00

The ASR proportional gain 1 adjusts the speed in response to speed deviation, and softens the effect of changes in load. Speed response increases as the proportional gain is increased. However, the load may become unstable if the ASR proportional gain is set too high.

Note: When parameter A1-02=1 (V/f control with PG) the factory default setting is 0.20. When parameter A1-02=3 (Flux Vector) the factory default setting is 20.00.

■ C5-02 ASR Integral Time 1

Setting Range: 0.000 to 10.000 sec
Factory Default: 0.500 sec

The ASR integral time 1 adjusts the Drive's response time to changes in load. Speed response increases as the integral time is decreased. However, the load may become unstable if the ASR integral time is set too low.

Note: When parameter A1-02=1 (V/f control with PG) the factory default setting is 0.200. When parameter A1-02=3 (Flux Vector) the factory default setting is 0.500.

■ C5-03 ASR Proportional Gain 2

Setting Range: 1.00 to 300.0
Factory Default: 20.00

The ASR proportional gain 2 is an additional proportional gain adjustment that can be enabled by either a multi-function contact input (H1-0x = 77) or the ASR switching frequency (C5-07).

Note: When parameter A1-02=1 (V/f control with PG) the factory default setting is 0.02. When parameter A1-02=3 (Flux Vector) the factory default setting is 20.00.

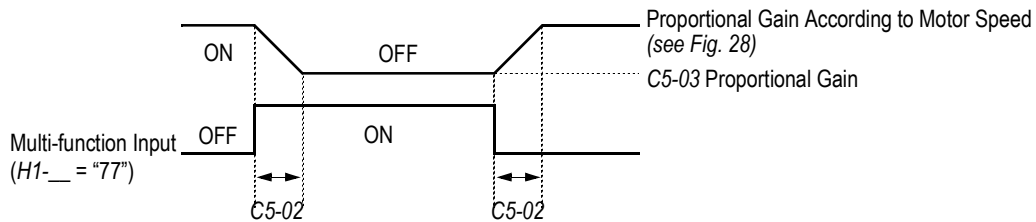

Fig. 27 ASR Multi-function Input Timing Diagram

■ C5-04 ASR Integral Time 2

Setting Range: 0.000 to 10.000 sec
Factory Default: 0.500 sec

The ASR integral time 2 is an additional integral time adjustment that can be enabled by the ASR switching frequency (C5-07).

Note: When parameter A1-02=1 (V/f control with PG) the factory default setting is 0.050. When parameter A1-02=3 (Flux Vector) the factory default setting is 0.500.

■ C5-05 ASR Limit

Setting Range: 0.0 to 20.0 %
 Factory Default: 5.0 %

Sets ASR frequency compensation limit as a percentage of maximum output frequency (E1-04). This function is enabled when V/f control with PG feedback is selected as the control method (A1-02).

■ C5-06 ASR Delay Time

Setting Range: 0.000 to 0.500 sec
 Factory Default: 0.004 sec

This parameter sets the filter time constant for the time from the speed loop to the torque command output. Mechanical backlash in an application causes secondary current (I_2) reference variations in the motor's rotor. This condition can prevent the adjustment of ASR parameters. The output delay time constant is used to control these secondary current (I_2) reference variations.

■ C5-07 ASR Switching Frequency

Setting Range: 0.0 to 400.0 Hz
 Factory Default: 20.0 Hz

Sets frequency to change ASR proportional gain and integral time constant in units of 0.1Hz when flux vector control is selected.

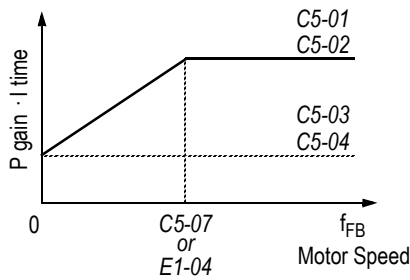

$$f_{FB} = \frac{P \cdot N}{120}$$

where:
 P = Number of Motor Poles
 N = Motor RPM

* When C5-07 = "0", proportional gain 1 (C5-01) and integral time 1 (C5-02) are selected.

Fig. 28 ASR Switching Frequency Level

Notes:

1. When C5-07 = 0, proportional gain 1 (C5-01) and integral time 1 (C5-02) are selected.
2. During V/f control with PG feedback (A1-02 = 1), the frequency switching level becomes the maximum output frequency (E1-04).
3. The multi-function input "77: ASR Gain Switch" has priority over the ASR switch frequency (C5-07).

■ C5-08 ASR Integral Limit

Setting Range: 0 to 400 %
 Factory Default: 400 %

Parameter C5-08 adjusts the amount of integral control of the automatic speed regulator in the Flux Vector control mode (A1-02 = 3). Setting parameter C5-08 to zero will make the ASR control proportional. Setting C5-08 to greater than 0% will make the ASR control proportional and integral.

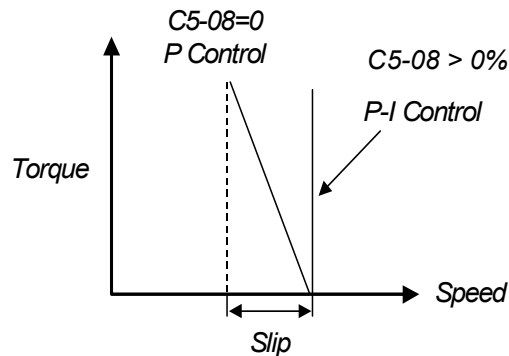

Fig. 29 ASR Integral Limit Function

◆ C6 Carrier Frequency

■ C6-01 Normal Duty Selection

Setting	Description
0	Heavy Duty (<i>factory default</i>)
1	Normal Duty 1
2	Normal Duty 2

The Drive's capacity is categorized based on three types of load characteristics: Heavy Duty, Normal Duty 1, and Normal Duty 2. The F7 User's and Programming Manual will only provide details on Heavy Duty and Normal Duty, where Normal Duty = Normal Duty 2 rating. Normal Duty 1 and Normal Duty 2 is only referenced wherever parameter C6-01 selections are mentioned in the manuals. This section explains the differences between Heavy Duty, Normal Duty 1, and Normal Duty 2. Adjustment of parameter C6-01 will affect the Drive's rated current, overload capacity, current limit, carrier frequency, and maximum output frequency.

The table below describes the general differences between Heavy Duty, Normal Duty 1, and Normal Duty 2. The Drive's nameplate shows the Heavy Duty and Normal Duty 2 current ratings. Normal Duty 1 is not printed on the nameplate, but its current rating is the same as Heavy Duty (HD).

Normal Duty 1 is the only rating that allows the carrier frequency to be increased above factory default setting. When the carrier frequency (C6-02) is set above the factory default setting in Normal Duty 1 (C6-01 = 1), the Drive's output current must be derated. Please consult Yaskawa for details on derating.

Table 1 Drive Duty Selection

Parameter C6-01	Rated Output Current	Overload Capacity	Current Limit	Carrier Frequency	Maximum Output Frequency
0: Heavy Duty (default)	Heavy Duty (HD) Nameplate Rating (varies by model*)	150% for 1 min.	150%	Low (2kHz)	300 Hz
1: Normal Duty 1	Heavy Duty (HD) Nameplate Rating (varies by model*)	120% for 1 min.	120%	High (varies by model*)	400 Hz
2: Normal Duty 2	Normal Duty (ND) Nameplate Rating (varies by model*)	Approx. 110% for 1 min. (varies by model*)	120%	Moderate (varies by model*)	400 Hz

* See specification in the F7 Drive Users Manual (TM.F7.01) for details.

■ C6-02 Carrier Frequency Selection

Setting	Description
0	Low Noise
1	Fc=2.0 kHz
2	Fc=5.0 kHz
3	Fc=8.0 kHz
4	Fc=10.0 kHz
5	Fc=12.5 kHz
6	Fc=15.0 kHz
F	Program

*The factory default setting is model dependent

Parameter C6-02 sets the switching frequency of the Drive's output transistors. It can be changed in order to reduce audible noise and also reduce leakage current. Cases that may require adjustment to the C6-02 are:

- If the wiring length between the Drive and the motor is long, decrease the carrier frequency

Wiring Length	164 ft or less	328 ft or less	Over 328 ft
C6-02 (carrier frequency) setting	1 to 6 (15 kHz max.)	1 to 4 (10 kHz max.)	1 to 2 (5 kHz max.)

- If speed and torque are inconsistent at low speeds, decrease the carrier frequency
- If leakage current from the Drive is large, decrease the carrier frequency
- If the audible motor noise is too great, increase the carrier frequency (may require Drive current derating)

When parameter C6-02 is set to “0: Low Noise” the Drive uses a carrier frequency of 2 kHz and reduces the motor audible noise by approximately 5 dB. over the conventional 2 kHz setting (C6-02= 1). The Drive modulates the nominal PWM pattern to achieve the lower noise. This setting is normally used with high starting torque loads that are frequently started and stopped or, applications where leakage current needs to be minimized and motor audible noise is important.

If parameter C6-01 = “0: Heavy Duty”, C6-02 can only be set to 0 or 1.

208V-240V Drives 1						480V Drives 1					
Model CIMR-F7U	C6-02 Carrier Frequency (kHz)	C6-03 Carrier Frequency Max. (kHz)	C6-04 Carrier Frequency Min. (kHz)	C6-05 Carrier Frequency Gain	Nominal HP	Model CIMR-F7U	C6-02 Carrier Frequency (kHz)	C6-03 Carrier Frequency Max. (kHz)	C6-04 Carrier Frequency Min. (kHz)	C6-05 Carrier Frequency Gain	Nominal HP
20P4	4 (10.0)	4 (10.0)	4 (10.0)	0	0.5/0.75	40P4	6 (15.0)	6 (15.0)	6 (15.0)	0	0.5/0.75
20P7	4 (10.0)	4 (10.0)	4 (10.0)	0	1	40P7	6 (15.0)	6 (15.0)	6 (15.0)	0	1
21P5	4 (10.0)	4 (10.0)	4 (10.0)	0	1.5/2	41P5	6 (15.0)	6 (15.0)	6 (15.0)	0	1.5/2
22P2	3 (8.0)	3 (8.0)	3 (8.0)	0	3	42P2	6 (15.0)	6 (15.0)	6 (15.0)	0	3
23P7	4 (10.0)	4 (10.0)	4 (10.0)	0	5	43P7	6 (15.0)	6 (15.0)	6 (15.0)	0	5
25P5	6 (15.0)	6 (15.0)	6 (15.0)	0	7.5	45P5	6 (15.0)	6 (15.0)	6 (15.0)	0	7.5
27P5	6 (15.0)	6 (15.0)	6 (15.0)	0	10	47P5	6 (15.0)	6 (15.0)	6 (15.0)	0	10
2011	3 (8.0)	3 (8.0)	3 (8.0)	0	15	4011	3 (8.0)	3 (8.0)	3 (8.0)	0	15/20
2015	4 (10.0)	4 (10.0)	4 (10.0)	0	20	4015	4 (10.0)	4 (10.0)	4 (10.0)	0	25
2018	4 (10.0)	4 (10.0)	4 (10.0)	0	25	4018	4 (10.0)	4 (10.0)	4 (10.0)	0	30
2022	4 (10.0)	4 (10.0)	4 (10.0)	0	30	4030	3 (8.0)	3 (8.0)	3 (8.0)	0	40/50
2030	4 (10.0)	4 (10.0)	4 (10.0)	0	40	4037	3 (8.0)	3 (8.0)	3 (8.0)	0	60
2037	2 (5.0)	2 (5.0)	2 (5.0)	0	50	4045	3 (8.0)	3 (8.0)	3 (8.0)	0	75
2045	2 (5.0)	2 (5.0)	2 (5.0)	0	60	4055	2 (5.0)	2 (5.0)	2 (5.0)	0	100
2055	3 (8.0)	3 (8.0)	3 (8.0)	0	75	4075	2 (5.0)	2 (5.0)	2 (5.0)	0	125
2075	1 (2.0)	1 (2.0)	1 (2.0)	0	75/100	4090	3 (8.0)	3 (8.0)	3 (8.0)	0	150
2090	1 (2.0)	1 (2.0)	1 (2.0)	0	125	4110	2 (5.0)	2 (5.0)	2 (5.0)	0	200
2110	1 (2.0)	1 (2.0)	1 (2.0)	0	150	4160	2 (5.0)	2 (5.0)	2 (5.0)	0	250
						4185	1 (2.0)	1 (2.0)	1 (2.0)	0	300/350
						4220	1 (2.0)	1 (2.0)	1 (2.0)	0	450
						4300	1 (2.0)	1 (2.0)	1 (2.0)	0	500+

■ **C6-03 Carrier Frequency Upper Limit**
C6-04 Carrier Frequency Lower Limit

Setting Range: 0.4 to 15.0 kHz
 Factory Default: Model Dependent

■ **C6-05 Carrier Frequency Proportional Gain**

Setting Range: 0 to 99
 Factory Default: 0

It is possible to configure the Drive such that the carrier frequency will automatically increase as the output frequency is raised (synchronous carrier). A synchronous carrier can be used by setting parameter C6-02 = "F: Program". The profile of the carrier frequency is show below and can be configured to the users specification by setting the carrier frequency upper and lower limits (C6-03 and C6-04 respectively) and a carrier frequency proportional gain (C6-05).

If parameter C6-01 = "0: Heavy Duty", parameters C6-03 cannot be changed and parameters C6-04 and C6-05 are not displayed.

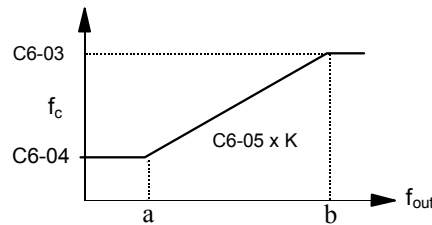

Fig. 30 ASR Integral Limit Function

The frequencies that correspond to the breakpoints a and b will be determined by the value of K given in the table below and the following formulas:

Conditions	K Value
$C6-03 > 10.0\text{kHz}$	3
$10.0\text{kHz} > C6-03 > 5.0\text{kHz}$	2
$C6-03 < 5.0\text{kHz}$	1

$$a = \frac{C6-04}{C6-05 \times K}$$

$$b = \frac{C6-03}{C6-05 \times K}$$

IMPORTANT | If $C6-05 > 6$ and $C6-04 > C6-03$ the Drive will fault and display and OPE11 error.

◆ d1 Preset References

- d1-01 Frequency Reference 1
- d1-02 Frequency Reference 2
- d1-03 Frequency Reference 3
- d1-04 Frequency Reference 4
- d1-05 Frequency Reference 5
- d1-06 Frequency Reference 6
- d1-07 Frequency Reference 7
- d1-08 Frequency Reference 8
- d1-09 Frequency Reference 9
- d1-10 Frequency Reference 10
- d1-11 Frequency Reference 11

d1-12 Frequency Reference 12

d1-13 Frequency Reference 13

d1-14 Frequency Reference 14

d1-15 Frequency Reference 15

d1-16 Frequency Reference 16

Setting Range: 0.00 to E1-04 Value
Factory Default: 0.00 Hz

■ d1-17 Jog Frequency Reference

Setting Range: 0.00 to E1-04 Value
Factory Default: 6.00 Hz

The Drive can be programmed to utilize digital inputs to change between 16 presets speeds and a jog speed. It is a two-step process to set the Drive up for preset speeds. First, d1-01 through d1-16 and d1-17 must be programmed with the desired pre-set speeds and the desired jog speed, respectively. Next, up to four terminals S3 through S8 need to be programmed (via parameters H1-01 to H1-06) and wired (to normally open contacts) as “3: Multi-step Speed Reference 1”, “4: Multi-step Speed Reference 2”, “5: Multi-step Speed Reference 3”, “32: Multi-step Speed Reference 4”, and “6: Jog Frequency”.

Table 4 Multi-step Speed Operation Timing Diagram

Preset Speed	Multi-step Reference 1	Multi-step Reference 2	Multi-step Reference 3	Multi-step Reference 4	Jog Reference	Details
1	OFF	OFF	OFF	OFF	OFF	Frequency Reference 1 (d1-01) or Analog Input A1
2	ON	OFF	OFF	OFF	OFF	Frequency Reference 2 (d1-02) or Analog Input A2 or A3 Aux Reference 1
3	OFF	ON	OFF	OFF	OFF	Frequency Reference 3 (d1-03) or Analog Input A2 or A3 Aux Reference 2
4	ON	ON	OFF	OFF	OFF	Frequency Reference 4 (d1-04)
5	OFF	OFF	ON	OFF	OFF	Frequency Reference 5 (d1-05)
6	ON	OFF	ON	OFF	OFF	Frequency Reference 6 (d1-06)
7	OFF	ON	ON	OFF	OFF	Frequency Reference 7 (d1-07)
8	ON	ON	ON	OFF	OFF	Frequency Reference 8 (d1-08)
9	OFF	OFF	OFF	ON	OFF	Frequency Reference 9 (d1-09)
10	ON	OFF	OFF	ON	OFF	Frequency Reference 10 (d1-10)
11	OFF	ON	OFF	ON	OFF	Frequency Reference 11 (d1-11)
12	ON	ON	OFF	ON	OFF	Frequency Reference 12 (d1-12)
13	OFF	OFF	ON	ON	OFF	Frequency Reference 13 (d1-13)
14	ON	OFF	ON	ON	OFF	Frequency Reference 14 (d1-14)
15	OFF	ON	ON	ON	OFF	Frequency Reference 15 (d1-15)
16	ON	ON	ON	ON	OFF	Frequency Reference 16 (d1-16)
JOG	-	-	-	-	ON*	Jog Frequency (d1-17)

* The Jog Frequency input is given priority over the multi-step speeds.

As shown in the above table, it is possible to use analog inputs in place of Frequency Reference 1, Frequency Reference 2, or Frequency Reference 3.

- If b1-01= “1: Terminals” then the analog input A1 will be used instead of Frequency Reference 1 for the first preset speed. If b1-01= “0: Operator”, then Frequency Reference 1 (d1-01) will be used.
- If H3-05 or H3-09= “2: Aux Reference 1” then the analog input A3 or A2, respectively, will be used instead of Frequency Reference 2 for the second preset speed. If H3-05 or H3-09 ≠ 2 then Frequency Reference 2 (d1-02) will be used.

- If H3-05 or H3-09= “3: Aux Reference 2” then the analog input A3 or A2, respectively will be used instead of Frequency Reference 3 for the third preset speed. If H3-05 or H3-09 ≠ 3 then Frequency Reference 3 (d1-03) will be used.

IMPORTANT

The programming of d1-01 through d1-04 and d1-17 will be affected by the setting of o1-03. The programming of these parameters will be in the units specified by Display Scaling parameter (o1-03).

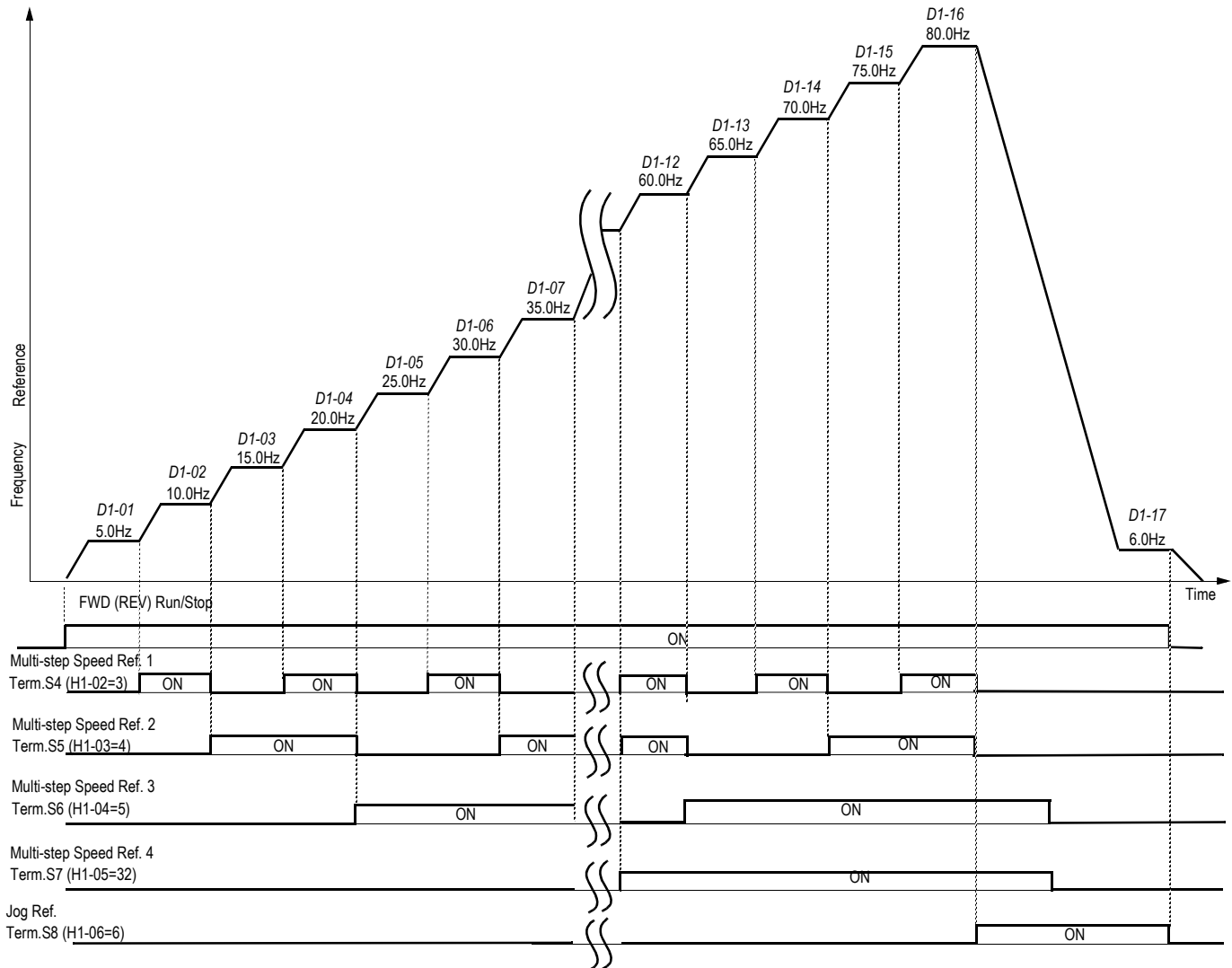

Fig. 31 Preset Reference Timing Diagram

■ **d1-17 Jog Frequency Reference**

Setting Range: 0.00 to E1-04 Value

Factory Default: 6.00 Hz

The Drive can be programmed to utilize digital inputs to change between four presets speeds and a jog speed. It is a two-step process to set the Drive up for preset speeds. First, d1-01 through d1-04 and d1-17 must be programmed with the desired preset speeds and the desired jog speed, respectively. Next, up to three of the Drive's digital inputs (Terminals S3 through S8) need to be programmed (via parameters H1-01 to H1-06) and wired (to normally open contacts) as Multi-step Speed Reference 1, Multi-step Speed Reference 2, and Jog Frequency.

As shown in the above table, it is possible to use analog inputs in place of Frequency Reference 1 and Frequency Reference 2.

- If b1-01= "1: Terminals" then the analog input A1 will be used instead of Frequency Reference 1 for the first preset speed. If b1-01= "0: Operator", then Frequency Reference 1 will be used.
- If H3-09= "2: Aux Reference" then the analog input A2 will be used instead of Frequency Reference 2 for the second preset speed. If H3-09≠2 then Frequency Reference 2 will be used.

IMPORTANT

The programming of d1-01 through d1-04 and d1-17 will be affected by the setting of o1-03. The programming of these parameters will be in the units specified by Display Scaling parameter (o1-03).

◆ d2 Reference Limits

■ d2-01 Frequency Reference Upper Limit

Setting Range: 0.0 to 110.0%
 Factory Default: 100.0%

■ d2-02 Frequency Reference Lower Limit

Setting Range: 0.0 to 110.0%
 Factory Default: 0.0%

The use of parameters d2-01 and d2-02 places limitations on the frequency reference that the Drive will accept. The parameters are set in units of percentage of the maximum frequency (E1-04) and cause dead bands on any remote frequency reference input. By entering upper or lower frequency limits, the Drive programmer can prevent operation of the Drive above or below levels that may cause resonance and or equipment damage.

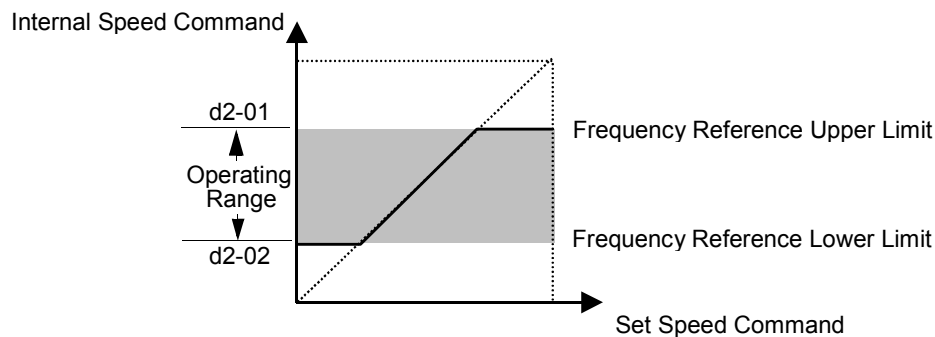

Fig. 32 Frequency Reference Upper and Lower Limit Effects on the frequency reference

■ d2-03 Master Speed Reference Lower Limit

Setting Range: 0.0 to 110.0%

Factory Default: 0.0%

Unlike Frequency Reference Lower Limit (d2-02) which will affect the frequency reference no matter where it is sourced from (i.e. analog input, preset speed, jog speed, etc.), the Master Speed Reference Lower Limit (d2-03) sets a low speed threshold that will only affect the analog input (terminals A1, A2, and A3) that is the active master speed frequency. This parameter allows a minimum speed to be programmed for the master reference while allowing a lower speed to be set as a jog reference. If the frequency referenced by the active master speed frequency is below the setting of d2-03, then the Drive will operate at the speed specified by d2-03.

◆ d3 Jump Frequencies

■ d3-01 Jump Frequency 1

d3-02 Jump Frequency 2

d3-03 Jump Frequency 3

Setting Range: 0.0 to 200.0 Hz

Factory Default: 0.0 Hz

■ d3-04 Jump Frequency Width

Setting Range: 0.0 to 20.0 Hz

Factory Default: 1.0 Hz

In order to avoid continuous operation at a speed that causes resonance in driven machinery, the Drive can be programmed with jump frequencies that will not allow continued operation within specific frequency ranges. If a speed is commanded that falls within a dead band, or Jump Frequency, the Drive will clamp the frequency reference just below the dead band and only accelerate past it when the commanded speed rises above the upper end of the dead band, for increasing references. Similarly, the Drive will clamp the frequency reference just above the dead band and only decelerate past it when the command speed falls below the lower end of the dead band, for decreasing references.

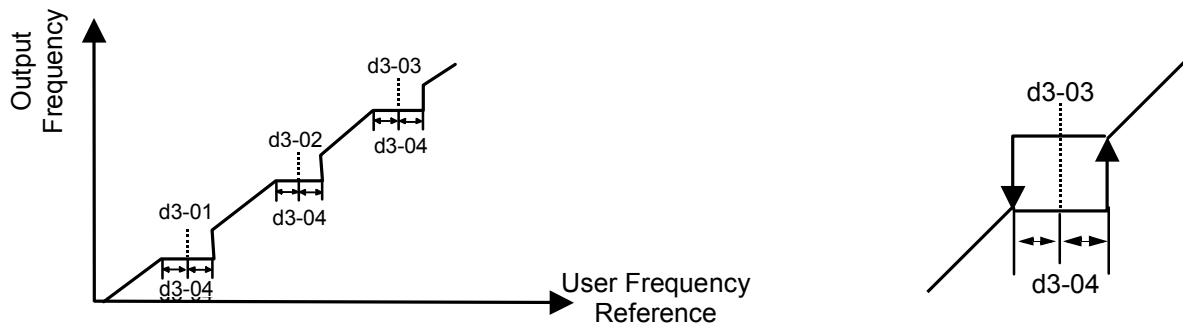

Fig. 33 Jump Frequency Characteristics

Setting the center point of the dead band with the d3-01 through d3-03 parameters and setting the width of the dead band with parameter d3-04 determine the dead band characteristics. The programmer can set up to three Jump Frequencies. If multiple Jump Frequencies are programmed the following rule applies:

$$d3-01 \leq d3-02 \leq d3-03$$

◆ d4 Sequence

■ d4-01 MOP Reference Memory

Setting	Description
0	Disabled (<i>factory default</i>)
1	Enabled

The Drive offers the capacity to change the frequency reference much the way a Motor Operated Potentiometer (MOP) would. Using programmed digital inputs configured as MOP Increase (H1-0x= 10) and MOP Decrease (H1-0x= 11), the Drive will increase the frequency reference whenever the MOP Increase input is closed and decrease the frequency reference whenever the MOP Decrease is closed. The frequency reference will remain constant whenever both inputs are open or closed.

Parameter d4-01 determines whether the last frequency reference, before the Run command was removed, is remembered even if the power is cycled to the Drive. If d4-01= "0: Disabled", then when a new Run command is issued the Drive's frequency reference will be 0 rpm. If d4-01= "1: Enabled", then the frequency reference will be the last commanded speed before the Run command was removed. See figure below.

■ d4-02 Trim Control Level

Setting Range: 0 to 100% of Maximum Speed
Factory Default: 10% of Maximum Speed

Using digital inputs, the Drive can add or subtract a set percentage of the maximum output frequency (E1-04) to or from the frequency referenced by the analog input. Parameter d4-02 sets the percentage that will be used to trim the frequency reference. Once the applicable digital input that is configured as either the Trim Control Increase (H1-0x= 1C) or Trim Control Decrease (H1-0x= 1D) is re-opened, the speed will go back to the speed determined by the analog reference.

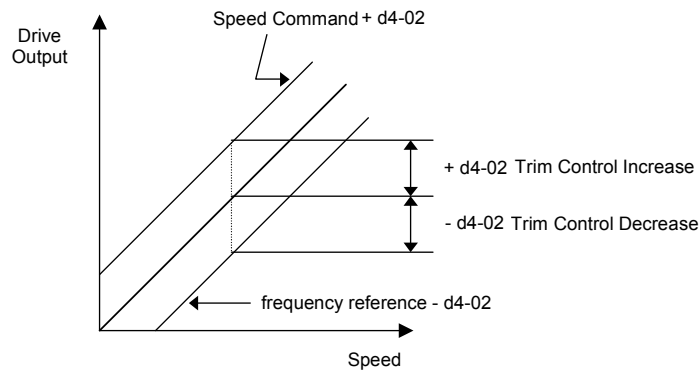

Fig. 34 Trim Control Effect on frequency reference

◆ d5 Torque Control

■ d5-01 Torque Control Selection

Setting	Description
0	Speed Control (<i>factory default</i>)
1	Torque Control

Selects between speed and torque control during flux vector operation (A1-03 = 3). Torque reference is set via analog input terminal A2 or A3 when it is set for “torque reference” (H3-09 or H3-05 = 13, respectively). Torque reference is set as a percentage of motor rated torque.

To switch between speed and torque control using a contact closure, set parameter d5-01 = 0 and set one of the multi-function contact inputs to “71: speed/torque control change” (H1-0x = 71).

■ d5-02 Torque Reference Delay Time

Setting Range: 0 to 1000 ms
Factory Default: 0 ms

Sets the torque reference delay time to correct for noise in the torque control signal or the responsiveness with the host controller. When oscillation occurs during torque control, increase the set value.

■ d5-03 Speed Limit Selection

Setting	Description
1	Analog Input (<i>factory default</i>) - Limited by the output of the soft starter (b1-01 selection and active acceleration / deceleration and S-curve settings.)
2	Program Setting - Limited by d5-04 setting

Sets the speed limit command method for the torque control method.

■ d5-04 Speed Limit

Setting Range: -120 to 120 %
Factory Default: 0 %

Sets the speed limit during torque control as a percentage of the maximum output frequency (E1-04). This function is enabled when d5-03 is set to 2. Directions are as follows:

- + run command direction
- run command opposite direction

■ d5-05 Speed Limit Bias

Setting Range: 0 to 120 %
Factory Default: 10 %

Sets the speed limit bias as a percentage of maximum output frequency (E1-04). Bias is given to the specified speed limit. It can be used to adjust the margin for the speed limit.

■ d5-06 Speed / Torque Control Switchover Timer

Setting Range: 0 to 1000 ms

Factory Default: 0 ms

This parameter sets the delay time from inputting the multi-function input “speed/torque control change” (from ON to OFF or OFF to ON) until the control is actually changed. This function is enabled when the multi-function input “speed/torque control change” (H1-0x = 71) is set. While in the speed / torque control switching timer, the analog inputs hold the value present when the “speed/torque control change” is received.

Inputting Torque References and Torque Reference Directions

The torque reference can be set according to an analog input by setting parameter H3-09 (terminal A2 selection) or H3-05 (terminal A3 selection) to “13: Torque Reference” or “14: Torque Compensation”. The torque reference input methods are listed in the table below.

The direction of the torque output from the motor will be determined by the sign of the analog input signal. It does not depend on the direction of the run command. The direction of torque will be as follows:

Positive analog reference: Torque reference for forward motor rotation (counter-clockwise as viewed from the motor output shaft)

Negative analog reference: Torque reference for reverse motor rotation (clockwise as viewed from the motor output shaft)

Table 5 Torque Reference

Torque Reference Input Method	Reference Source	Parameter Setting	Remarks
Voltage Input (0 to +/- 10 V)	Terminal A3 - AC	H3-04 = 1 H3-05 = 13	Set H3-04 to 0 for a 0 to 10V torque reference. To switch the torque reference between positive and negative torque, set a multi-function digital input to 78.
	Terminal A2 - AC (turn off pin 2 of SW1)	H3-08 = 1 H3-09 = 13	Set H3-08 to 0 for a 0 to 10V torque reference. To switch the torque reference between positive and negative torque, set a multi-function digital input to 78. The input can be used for torque compensation by setting H3-09 to 14.
Current Input (4 to 20 mA)	Terminal A2 - AC (turn off pin 2 of SW1)	H3-08 = 2 H3-09 = 13	To switch the torque reference between positive and negative torque, set a multi-function digital input to 78. The input can be used for torque compensation by setting H3-09 to 14.
Option Board (AI-14B) (0 to +/-10 V)	TC2 - TC4	F2-01 = 0 H3-08 = 1 H3-09 = 13	The input can be used for torque compensation by setting H3-09 to 14.

Note: If the analog input level is 0 to 10 V or 4 to 20 mA, a forward torque reference will only be applied. To apply reverse torque reference, use an analog input level of -10 to 10 V or switch the direction using a multi-function input set to “78: polarity reverse command”.

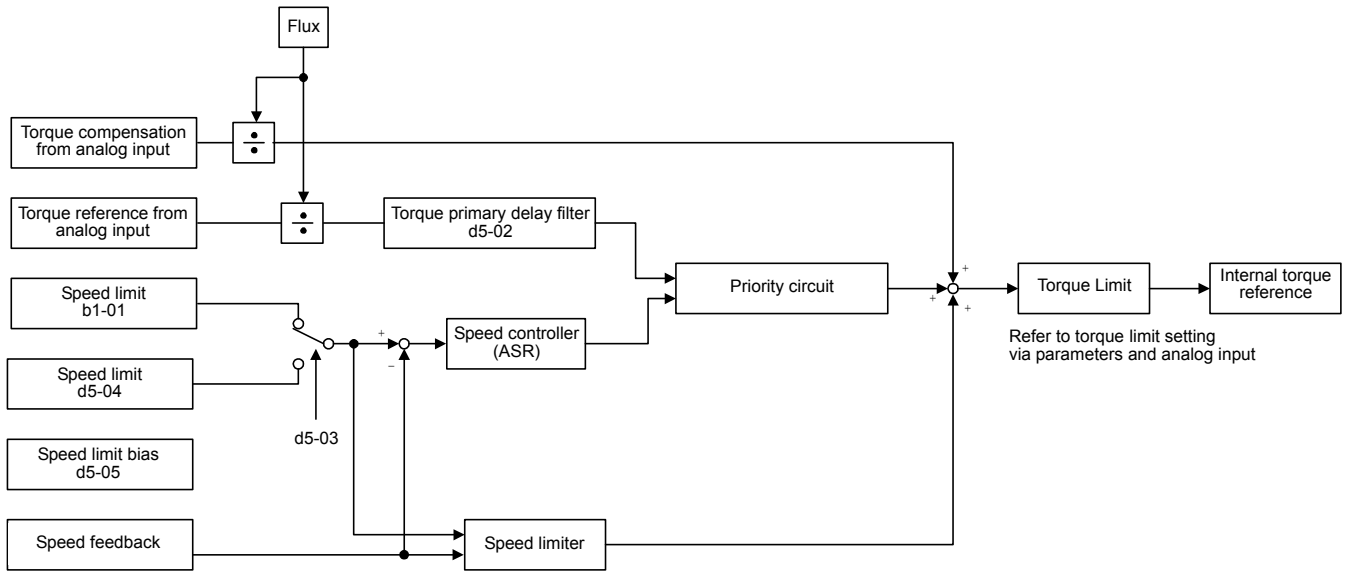

Fig. 35 Torque Control Block Diagram

Speed Limiter and Priority Circuit (Speed Limit Function)

If the external torque reference and load are not balanced during torque control, the motor will accelerate in either the forward or reverse direction. The speed limit function is used to limit the speed to a specified value, which consists of the speed limiter circuit and priority circuit.

There are two ways to set a speed limit: using an input from an analog input terminal and setting a speed limit in d5-04. The input methods for speed limit are listed in the following table.

Table 6 Speed Limit			
Speed Limit Input Method	Reference Source	Parameter Setting	Remarks
Voltage Input (0 to +/- 10 V)	Set in d5-04	d5-03 = 2	-
	Terminal A1 - AC	d5-03 = 1 b1-01 = 1 H3-01 = 1	Set H3-01 to 0 if the speed limit is always to be positive.
	Terminal A2 - AC	d5-03 = 1 b1-01 = 0 H3-08 = 1 H3-09 = 1	The value will be added to the value input on A1 to set the speed limit. Set H3-03 to 0 if the speed limit input on A2 is always to be positive. Turn OFF (V side) pin 2 of switch S1 on the terminal board.
	Terminal A3 - AC	d5-03 = 1 b1-01 = 0 H3-04 = 1 H3-05 = 1	The value will be added to the value input on A1 to set the speed limit. Set H3-07 to 0 if the speed limit input on A3 is always to be positive.
Current Input (4 to 20 mA)	Terminal A2 - AC	d5-03 = 1 b1-01 = 0 H3-08 = 2 H3-09 = 1	The value will be added to the value input on A1 to determine the speed limit. Turn ON pin 2 of switch S1 on the terminal board.
Option Board (AI-14B) (0 to +/-10 V)	TC1 - TC4	d5-03 = 1 b1-01 = 3 F2-01 = 0	If H3-009 is set to 0, the sum of the input between TC2 and TC4 will be added to the input between TC1 and TC4 to determine the speed limit.

The direction in which speed is controlled is determined by the sign of the speed limit signal and the direction of the run command.

Positive voltage applied: The speed in the forward direction will be limited for forward operation.

Negative voltage applied: The speed in the reverse direction will be limited for reverse operation.

If the direction of the motor rotation and the command direction are not the same, speed will be limited to zero as long as d5-05 is set to zero. The direction of the run command determines the polarity of the speed limit.

Example:

Fmax - E1-04 = 60 Hz

Speed limit bias - d5-05 = 10%

No load on motor - Drive will always run up to speed limit

Run Direction	Torque Reference	Output Frequency
FWD	100%	46Hz
FWD	-100%	-6Hz
REV	100%	6Hz
REV	-100%	-46Hz

Speed Limit Bias Setting

The speed limit bias can be set to limit both the forward and reverse speed to the same value. This differs from the operation of the speed limit setting. To use the speed limit bias, set d5-04 to 0 and set the bias in d5-05 as a percentage of the maximum output frequency.

To set 50% forward and reverse speed limits, set the speed limit setting to 0 (d5-03 = 2, d5-04 = 0, and d5-05 = 50). The range of torque control will be from -50% to 50% of the maximum output speed.

When using both the speed limit and the speed limit bias, the range of torque control will be positive and negative speed limits with the speed limit bias added to each.

The range of torque control when the forward speed limit is 50% and the speed limit bias is 10% as shown in the following figure. This figure does not take the priority circuit into account.

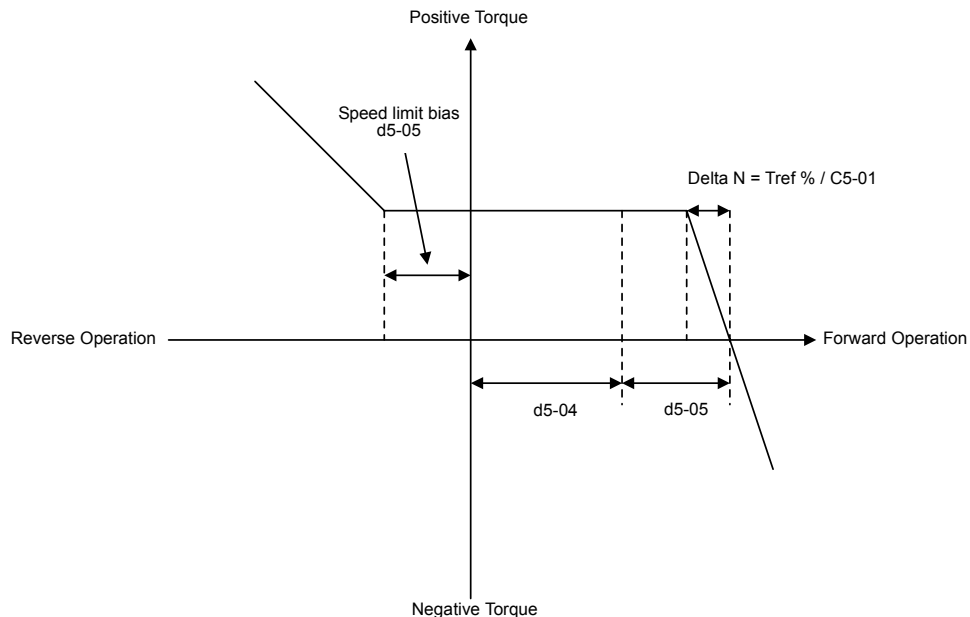

Fig. 36 Speed Limit Bias Setting

Torque Limit Operation Examples

Operation examples will be described separately for winding operation, in which the speed and motor torque are in the same directions, and rewinding operation, in which the speed and motor torque are in opposite directions.

Winding Operation

In a winding operation, the line (speed) and torque generated by the motor are in the same direction. For the winding operation, both the speed limit and the torque reference input are positive. The motor will accelerate when the torque reference input is larger than the load and will decelerate when it is smaller than the load. If the motor turns faster than the speed limit, a negative compensation value is output from the speed limiter circuit. When the speed then drops below the speed limit, a positive compensation value is output. The torque compensation is proportional to the ASR proportional gain. When the sum of the torque reference and the torque compensation output by the speed limiter is the same as the actual load, the motor will stop accelerating and run at a constant speed.

Rewinding Operation

In a rewinding operation, the line (speed) and torque generated by the motor are in the opposite directions. (In this example, it is assumed that the line speed is positive and the torque reference input is negative.) For the rewinding operation, the speed limit is positive and the torque reference input is negative. If the motor turns faster than the speed limit, a negative compensation value is output. If the speed is zero or is below the speed limit, a zero compensation value is output. In this way, the output from the speed limiter is used to maintain the motor speed between zero and the speed limit. When the sum of the torque reference and the torque compensation output by the speed limiter is the same as the actual load, the motor will stop accelerating and run at a constant speed.

Table 7 Torque Control Example					
		Winding Operation		Rewinding Operation	
Configuration					
Direction of Motor Rotation		Forward	Reverse	Forward	Reverse
Reference Polarity	Torque Reference (TREF)	+	-	-	+
	Speed Limit (NLIM)	+	-	+	-
Torque Profile		<p>$\Delta N(\%) = TREF(\%) / C5-01$</p>	<p>$\Delta N(\%) = TREF(\%) / C5-01$</p>	<p>Smaller of $\Delta N(\%) = TREF(\%) / C5-01$ $= TREF(\%) / d5-05(\%)$</p>	<p>Smaller of $\Delta N(\%) = TREF(\%) / C5-01$ $= TREF(\%) / d5-05(\%)$</p>

The following figure shows the timing diagram of speed/torque selection.

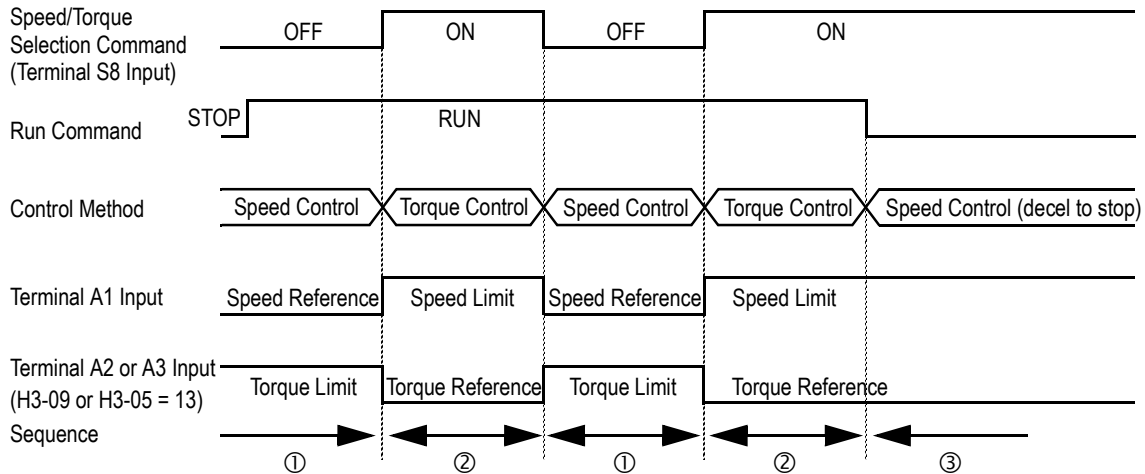

Fig. 37 Speed / Torque Control Selection Timing Diagram

Timing Diagram Description

- ① When the speed/torque control selection contact is OFF, speed control is activated.
 - Speed reference during speed control depends on the frequency reference selection (B1-01) setting. To use terminal A1 or A2 as the master frequency reference, set b1-01 to “1”.
 - Torque limit during speed control is the smaller of the absolute value of terminal A3 torque limit, or the values set in the torque limit parameters (L7-01 to L7-04).
 - When a stop command is given during speed control, speed control is maintained and the smaller of the absolute value of terminal A3 torque limit, or the values set in the torque limit parameters (L7-01 to L7-04), is used as the torque limit. Then the motor decelerates to stop.
- ② When the speed/torque control selection contact is ON, torque control is activated.
 - Speed limit during torque control is the master frequency reference at terminal A1 or A2 when speed limit selection (D5-03) is set to “1”, and is the speed limit value (D5-04) when D5-03 = “2”, regardless of the frequency reference selection (B1-01) setting.
 - During torque control, the terminal A2 or A3 analog input value becomes the torque reference.
- ③ By giving a stop command during torque control, operation changes to speed control automatically, and the motor decelerates to stop. The torque limit during deceleration to stop becomes the values set in the torque limit parameters (L7-01 to L7-04).

Note: The control mode actually changes after the speed/torque control selection command changes and after the reference delay timer (D5-06) elapses. Terminal A1 speed reference/speed limit and the terminal A2 or A3 torque limit/torque reference are stored in the inverter until the time set to D5-06 elapses.

◆ d6 Field Weakening

■ d6-01 Magnetic Field Weakening Level

Setting Range: 0 to 100 %

Factory Default: 80 %

The output voltage during magnetic field weakening operation is the product of the normal V/f settings (E1-03 to E1-13) and the magnetic field weakening level. The output voltage decreases and recovers in the voltage recovery time (L2-04). The level is set as a percentage taking the voltage set in the V/f pattern as 100%. The magnetic field weakening function is only enabled when a multi-function input “field weakening command” is closed (H1-0x = 63).

■ d6-02 Magnetic Field Weakening Frequency

Setting Range: 0.0 to 400.0 Hz

Factory Default: 0.0 Hz

Sets the lower limit of the frequency range where field weakening control is valid. The field weakening command is valid only at frequencies above this setting and only when output frequency is in agreement with the current output frequency (speed agree).

■ d6-03 Magnetic Field Forcing Function Selection

Setting	Description
0	Disabled (<i>factory default</i>)
1	Enabled

Sets the magnetic field forcing function.

◆ E1 V/f Pattern

■ E1-01 Input Voltage Setting

Setting Range: 155.0V to 255.0V (240V Models)
310.0V to 510.0V (480V Models)

Factory Defaults: 240.0V (240V Models)
480.0V (480V Models)

Set the Input Voltage parameter (E1-01) to the nominal voltage of the connected AC power supply. This parameter adjusts the levels of some protective features of the Drive (i.e. Overvoltage, Stall Prevention, etc.). E1-01 also serves as the Maximum/Base Voltage used by the Preset V/Hz curves (E1-03= 0 to E).

WARNING

DRIVE INPUT VOLTAGE (NOT MOTOR VOLTAGE) MUST BE SET IN E1-01 FOR THE PROTECTIVE FEATURES OF THE DRIVE TO FUNCTION PROPERLY. FAILURE TO DO SO MAY RESULT IN EQUIPMENT DAMAGE AND/OR PERSONAL INJURY.

■ E1-03 V/f Pattern Selection

Setting	Description
0	50 Hz
1	60 Hz Saturation
2	50 Hz Saturation
3	72 Hz
4	50 Hz VT1
5	50 Hz VT2
6	60 Hz VT1
7	60 Hz VT2
8	50 Hz HST1
9	50 Hz HST2
A	60 Hz HST1
B	60 Hz HST2
C	90 Hz
D	120 Hz
E	180 Hz (not supported at this time)
F	Custom V/f (<i>factory default, with parameter values per setting 1</i>)
FF	Custom w/o limit

The Drive operates utilizing a set V/f pattern to determine the appropriate output voltage level for each commanded speed. There are 15 different preset V/f patterns to select from with varying voltage profiles, saturation levels (frequency at which maximum voltage is reached), and maximum frequencies.

There are also settings for Custom V/f patterns that will allow the programmer to manually set (“Customize”) the V/f pattern using parameters E1-04 through E1-13.

Using parameter E1-03, the programmer can select one of the preset V/f patterns or chose between a custom V/f pattern with an upper voltage limit (E1-03= “F: Custom V/F”) and a custom V/f pattern without a voltage limit (E1-03= “FF: Custom w/o limit”).

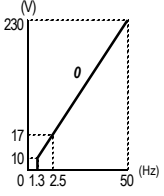
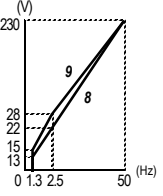
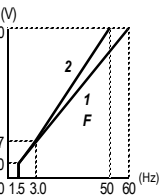
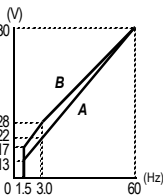
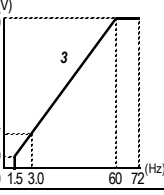
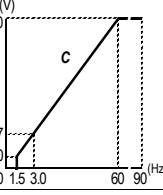
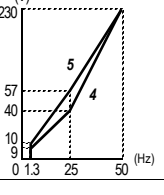
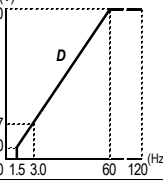
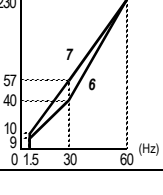
Table 8 Preset V/f Patterns								
	Specifications	E1-03	V/f Pattern *1		Specifications	E1-03	V/f Pattern *1	
General-purpose	50Hz	0		High Starting Torque *2	High Starting Torque 1	8		
			High Starting Torque 2		9			
	60Hz Saturation	1			High Starting Torque 1	A		
	50Hz Saturation	2			High Starting Torque 2	B		
	72Hz	3			90Hz	C		
Variable Torque	50Hz	Variable Torque 1		High Speed Operation	120Hz	D		
		Variable Torque 2						5
	60Hz	Variable Torque 1						
		Variable Torque 2						7

If one of the custom V/f patterns is selected, then parameters E1-04 through E1-13 will determine the V/f pattern.

IMPORTANT

When a factory Initialization is performed, the setting of E1-03 is unaffected but the settings of E1-04 through E1-13 are returned to their factory default settings.

■ **E1-04 Maximum Output Frequency**

Setting Range: 0.0 to 400.0 Hz
 Factory Default: 60.0 Hz

■ E1-05 Maximum Output Voltage

Setting Range: 0.0 to 255.0V (240V Models)
0.0 to 510.0V (480V Models)

Factory Defaults: 230.0V (240V Models)
480.0V (480V Models)

■ E1-06 Base Frequency

Setting Range: 0.0 to 400.0 Hz
Factory Default: 60.0 Hz

■ E1-07 Mid Output Frequency A

Setting Range: 0.0 to 400.0 Hz
Factory Default: 3.0 Hz

■ E1-08 Mid Output Voltage A

Setting Range: 0.0 to 255.0V (240V Models)
0.0 to 510.0V (480V Models)

Factory Defaults: 12.6V (240V Models)
25.2V (480V Models)

■ E1-09 Minimum Output Frequency

Setting Range: 0.0 to 400.0 Hz
Factory Default: 0.5 Hz

■ E1-10 Minimum Output Voltage

Setting Range: 0.0 to 255.0V (240V Models)
0.0 to 510.0V (480V Models)

Factory Defaults: 2.3V (240V Models)
4.6V (480V Models)

■ E1-11 Mid Output Frequency B

Setting Range: 0.0 to 400.0 Hz
Factory Default: 0.0 Hz

■ E1-12 Mid Output Voltage B

E1-13 Base Voltage

Setting Range: 0.0 to 255.0V (240V Models)
0.0 to 510.0V (480V Models)

Factory Defaults: 0.0V (240V Models)
0.0V (480V Models)

To set up a custom V/f pattern, program the points shown in the diagram below using parameters E1-04 through E1-13. Be sure that the following condition is true:

$$E1-09 \leq E1-07 \leq E1-06 \leq E1-11 \leq E1-04$$

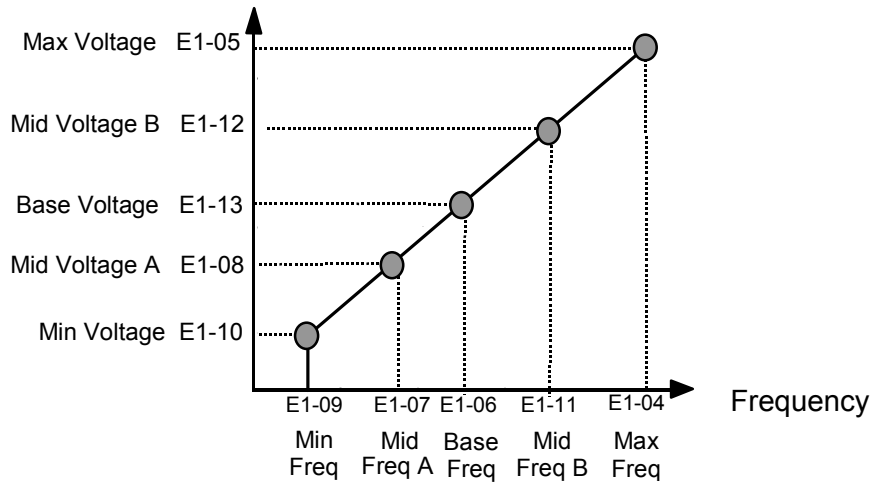

Fig.38 Custom V/f Pattern Programming Curve

Increasing the voltage in the V/f pattern increases the available motor torque. However, when setting a custom V/f pattern, increase the voltage gradually while monitoring the motor current, to prevent:

- Drive faults as a result of motor over-excitation
- Motor overheating or excessive vibration

Table 9 V/f Pattern Default Settings for Drive Capacity 0.4~1.5kW for 240V Class

Parameter No.	Name	Unit	Factory Setting							
			0	1	2	3	4	5	6	7
E1-03	V/f Pattern Selection	—	0	1	2	3	4	5	6	7
E1-04	Max Output Frequency	Hz	50.0	60.0	60.0	72.0	50.0	50.0	60.0	60.0
E1-05	Max Output Voltage	V	240.0	240.0	240.0	240.0	240.0	240.0	240.0	240.0
E1-06	Base Frequency	Hz	50.0	60.0	50.0	60.0	50.0	50.0	60.0	60.0
E1-07	Mid Output Frequency A	V	2.5	3.0	3.0	3.0	25.0	25.0	30.0	30.0
E1-08	Mid Output Voltage A	V	17.2	17.2	17.2	17.2	40.2	57.5	40.2	57.5
E1-09	Min Output Frequency	Hz	1.3	1.5	1.5	1.5	1.3	1.3	1.5	1.5
E1-10	Mid Output Voltage	V	10.3	10.3	10.3	10.3	9.2	10.3	9.2	10.3
E1-11	Mid Output Frequency B	Hz	0	0	0	0	0	0	0	0
E1-12	Mid Output Voltage B	V	0	0	0	0	0	0	0	0
E1-13	Base Voltage	V	0	0	0	0	0	0	0	0

For 480V class units, the value is twice that of 240V class units.

Table 9 V/f Pattern Default Settings for Drive Capacity 0.4~1.5kW for 240V Class (Continued)

Parameter No.	Name	Unit	Factory Setting							
			8	9	A	B	C	D	E	F
E1-03	V/f Pattern Selection	—	8	9	A	B	C	D	E	F
E1-04	Max. Output Frequency	Hz	50.0	50.0	60.0	60.0	90.0	120.0	180.0	60.0
E1-05	Max. Output Voltage	V	240.0	240.0	240.0	240.0	240.0	240.0	240.0	240.0
E1-06	Base Frequency	Hz	50.0	50.0	60.0	60.0	60.0	60.0	60.0	60.0
E1-07	Mid. Output Frequency A	V	2.5	2.5	3.0	3.0	3.0	3.0	3.0	3.0
E1-08	Mid. Output Voltage A	V	21.8	27.6	21.8	27.6	17.2	17.2	17.2	17.2
E1-09	Min. Output Frequency	Hz	1.3	1.3	1.5	1.5	1.5	1.5	1.5	1.5
E1-10	Mid. Output Voltage	V	12.6	14.9	12.6	17.2	10.3	10.3	10.3	10.3
E1-11	Mid Output Frequency B	Hz	0	0	0	0	0	0	0	0
E1-12	Mid Output Voltage B	V	0	0	0	0	0	0	0	0
E1-13	Base Voltage	V	0	0	0	0	0	0	0	0

For 480V class units, the value is twice that of 240V class units.

Table 10 V/f Pattern Default Settings for Drive Capacity 2.2~45kW for 240V Class

Parameter No.	Name	Unit	Factory Setting							
			0	1	2	3	4	5	6	7
E1-03	V/f Pattern Selection	—	0	1	2	3	4	5	6	7
E1-04	Max. Output Frequency	Hz	50.0	60.0	60.0	72.0	50.0	50.0	60.0	60.0
E1-05	Max. Output Voltage	V	240.0	240.0	240.0	240.0	240.0	240.0	240.0	240.0
E1-06	Base Frequency	Hz	50.0	60.0	50.0	60.0	50.0	50.0	60.0	60.0
E1-07	Mid. Output Frequency A	V	2.5	3.0	3.0	3.0	25.0	25.0	30.0	30.0
E1-08	Mid. Output Voltage A	V	16.1	16.1	16.1	16.1	40.2	57.5	40.2	57.5
E1-09	Min. Output Frequency	Hz	1.3	1.5	1.5	1.5	1.3	1.3	1.5	1.5
E1-10	Mid. Output Voltage	V	8.0	8.0	8.0	8.0	6.9	8.0	6.9	8.0
E1-11	Mid Output Frequency B	Hz	0	0	0	0	0	0	0	0
E1-12	Mid Output Voltage B	V	0	0	0	0	0	0	0	0
E1-13	Base Voltage	V	0	0	0	0	0	0	0	0

For 480V class units, the value is twice that of 240V class units.

Table 10 V/f Pattern Default Settings for Drive Capacity 2.2~45kW for 240V Class (Continued)

Parameter No.	Name	Unit	Factory Setting							
			8	9	A	B	C	D	E	F
E1-03	V/f Pattern Selection	—	8	9	A	B	C	D	E	F
E1-04	Max. Output Frequency	Hz	50.0	50.0	60.0	60.0	90.0	120.0	180.0	60.0
E1-05	Max. Output Voltage	V	240.0	240.0	240.0	240.0	240.0	240.0	240.0	240.0
E1-06	Base Frequency	Hz	50.0	50.0	60.0	60.0	60.0	60.0	60.0	60.0
E1-07	Mid. Output Frequency A	V	2.5	2.5	3.0	3.0	3.0	3.0	3.0	3.0
E1-08	Mid. Output Voltage A	V	20.7	26.4	20.7	26.4	16.1	16.1	16.1	16.1
E1-09	Min. Output Frequency	Hz	1.3	1.3	1.5	1.5	1.5	1.5	1.5	1.5
E1-10	Mid. Output Voltage	V	10.3	12.6	10.3	14.9	8.0	8.0	8.0	8.0
E1-11	Mid Output Frequency B	Hz	0	0	0	0	0	0	0	0
E1-12	Mid Output Voltage B	V	0	0	0	0	0	0	0	0
E1-13	Base Voltage	V	0	0	0	0	0	0	0	0

For 480V class units, the value is twice that of 240V class units.

Table 11 V/f Pattern Default Settings for Drive Capacity 55~300kW for 240V Class

Parameter No.	Name	Unit	Factory Setting							
			0	1	2	3	4	5	6	7
E1-03	V/f Pattern Selection	—	0	1	2	3	4	5	6	7
E1-04	Max. Output Frequency	Hz	50.0	60.0	60.0	72.0	50.0	50.0	60.0	60.0
E1-05	Max. Output Voltage	V	240.0	240.0	240.0	240.0	240.0	240.0	240.0	240.0
E1-06	Max. Voltage Frequency	Hz	50.0	60.0	50.0	60.0	50.0	50.0	60.0	60.0
E1-07	Mid. Output Frequency A	V	2.5	3.0	3.0	3.0	25.0	25.0	30.0	30.0
E1-08	Mid. Output Voltage A	V	13.8	13.8	13.8	13.8	40.2	57.5	40.2	57.5
E1-09	Min. Output Frequency	Hz	1.3	1.5	1.5	1.5	1.3	1.3	1.5	1.5
E1-10	Mid. Output Voltage	V	6.9	6.9	6.9	6.9	5.7	6.9	5.7	6.9
E1-11	Mid Output Frequency B	Hz	0	0	0	0	0	0	0	0
E1-12	Mid Output Voltage B	V	0	0	0	0	0	0	0	0
E1-13	Base Voltage	V	0	0	0	0	0	0	0	0

For 480V class units, the value is twice that of 240V class units.

Table 11 V/f Pattern Default Settings for Drive Capacity 55~300kW for 240V Class (Continued)

Parameter No.	Name	Unit	Factory Setting							
			8	9	A	B	C	D	E	F
E1-03	V/f Pattern Selection	–	8	9	A	B	C	D	E	F
E1-04	Max. Output Frequency	Hz	50.0	50.0	60.0	60.0	90.0	120.0	180.0	60.0
E1-05	Max. Output Voltage	V	240.0	240.0	240.0	240.0	240.0	240.0	240.0	240.0
E1-06	Base Frequency	Hz	50.0	50.0	60.0	60.0	60.0	60.0	60.0	60.0
E1-07	Mid. Output Frequency A	V	2.5	2.5	3.0	3.0	3.0	3.0	3.0	3.0
E1-08	Mid. Output Voltage A	V	17.2	23.0	17.2	23.0	13.8	13.8	13.8	13.8
E1-09	Min. Output Frequency	Hz	1.3	1.3	1.5	1.5	1.5	1.5	1.5	1.5
E1-10	Mid. Output Voltage	V	8.0	10.3	8.0	12.6	6.9	6.9	6.9	6.9
E1-11	Mid Output Frequency B	Hz	0	0	0	0	0	0	0	0
E1-12	Mid Output Voltage B	V	0	0	0	0	0	0	0	0
E1-13	Base Voltage	V	0	0	0	0	0	0	0	0

For 480V class units, the value is twice that of 240V class units.

◆ E2 Motor Setup

■ E2-01 Motor Rated Current

Setting Range: Model Dependent

Factory Default: Model Dependent

The Motor Rated Current parameter (E2-01) is used by the Drive to protect the motor and for proper Vector control when using Open Loop Vector or Flux Vector control methods (A1-02 = 2 or 3). The motor protection parameter L1-01 is enabled by default. Set E2-01 to the full load amps (FLA) stamped on the motor's nameplate.

During Auto-tuning, it is required for the operator to enter the motor's rated current (T1-04) in the Auto-Tuning menu. If the Auto-tuning operation completes successfully (T1-02 = 0), the value entered into T1-04 will automatically be written into E2-01.

■ E2-02 Motor Rated Slip

Setting Range: Model Dependent

Factory Default: Model Dependent

This parameter sets the motor rated slip frequency in units of 0.01Hz. If the rotational Auto-tuning operation completes successfully, this value is automatically calculated. The default setting varies depending on the drive model number (o2-04). The

following equation to calculate the motor rated slip frequency based on motor nameplate data:

$$f_s = f - \frac{(N \cdot P)}{120}$$

where:

f_s : slip frequency (Hz)
 f : rated frequency (Hz)
 N : rated motor speed (rpm)
 P : number of motor poles

■ E2-03 No Load Current

Setting Range: Model Dependent
Factory Default: Model Dependent

Set E2-03 to the motor no-load current at rated voltage and rated frequency. If the rotational Auto-tuning operation completes successfully (T1-02 = 0), this value is automatically calculated. Consult the motor manufacturer for the proper value if the no load current is not stated on the motor nameplate.

■ E2-04 Number of Motor Poles

Setting Range: 2 to 48
Factory Default: 4

This parameter sets the number of motor poles. During auto-tuning, it is required for the operator to enter the number of motor poles (T1-06) in the Auto-Tuning menu. If the Auto-tuning operation completes successfully (T1-02 = 0, 1, or 2), the value entered into T1-06 will automatically be written into E2-04.

■ E2-05 Motor Line-to-Line Resistance

Setting Range: 0.0000 to 65.000 Ω
Factory Default: 9.842 Ω

Sets the line-to-line resistance of the motor's stator winding. If the Auto-tuning operation completes successfully (T1-02 = 0, 1, or 2), this value is automatically calculated. Remember this value must be entered as line-line and not line neutral.

$$E2-05 = \left(\frac{\text{Phase-to-phase Resistance at Insulation Class Temperature}}{\text{Insulation Class Temperature}} \right) \times \frac{273 + (25 + \text{insulation class temperature}) / 2}{273 + \text{insulation class temperature}}$$

Where: Insulation class temperature is in $^{\circ}\text{C}$

■ E2-06 Motor Leakage Inductance

Setting Range: 0.0 to 40.0 %
Factory Default: Model Dependent

Sets the voltage drop due to motor leakage inductance as a percentage of motor rated voltage. If the rotational Auto-tuning operation completes successfully (T1-02 = 0), this value is automatically calculated.

■ E2-07 Motor Iron-core Saturation Coefficient 1

Setting Range: 0.00 to 0.50
Factory Default: 0.50

This parameter sets the motor iron saturation coefficient at 50% of the magnetic flux. If the rotational Auto-tuning operation completes successfully (T1-02 = 0), this value is automatically calculated.

■ E2-08 Motor Iron-core Saturation Coefficient 2

Setting Range: 0.50 to 0.75
Factory Default: 0.75

This parameter sets the motor iron saturation coefficient at 75% of the magnetic flux. If the rotational Auto-tuning operation completes successfully (T1-02 = 0), this value is automatically calculated.

■ E2-09 Motor Mechanical Loss

Setting Range: 0.0 to 10.0 %
Factory Default: 0.0 %

This parameter sets to the motor mechanical loss as a percentage of motor rated power (kW) capacity. Adjust this setting in the following circumstances:

- When torque loss is large due to motor bearing friction.
- When the torque loss in the load is large.

■ E2-10 Motor Iron Loss for Torque Compensation

Setting Range: 0 to 65535 W
Factory Default: Model Dependent

This parameter sets the motor iron loss in watts (W)

■ E2-11 Motor Rated Output

Setting Range: 0.00 to 650.00 kW
Factory Default: Model Dependent

This parameter sets the motor rated power in kilowatts (kW). If the rotational Auto-tuning operation completes successfully (T1-02 = 0), this value is automatically calculated.

1 horsepower = 0.746 kilowatts

■ E2-12 Motor Iron-core Saturation Coefficient 3

Setting Range: 0.0 to 1.60
Factory Default: 1.30

This parameter sets the motor iron saturation coefficient at 130% of the magnetic flux. If the rotational Auto-tuning operation completes successfully (T1-02 = 0), this value is automatically calculated.

◆ E3 V/F Pattern 2

■ E3-01 Motor 2 Control Method Selection

Setting	Description
0	V/f Control without PG
1	V/f Control with PG
2	Open Loop Vector (<i>factory default</i>)
3	Flux Vector (Closed Loop Vector)

The Drive has the capability to control 2 motors independently. A second motor may be selected using a multi-function contact input (H1-0x = 16). This parameter select the control method for motor 2. The control method for motor 1 is selected via parameter A1-02.

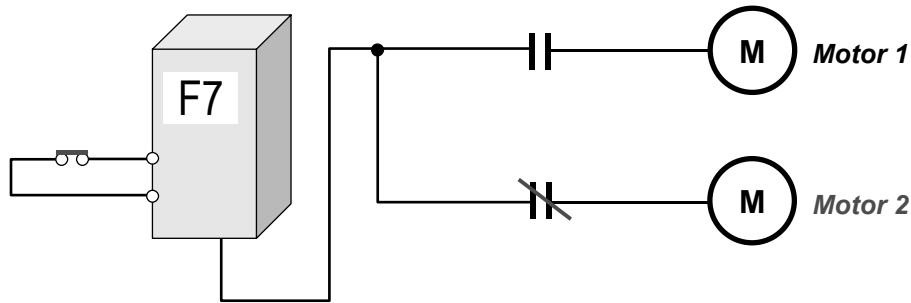

Fig. 39 Two Motor Switching Set-up

The following is a list of parameters that become effective when motor 2 is selected.

E3-08E

Table 12 Motor 2 Parameters			
V/f Pattern 2		Motor Setup 2	
E3-01	Control Method 2	E4-01	Motor Rated FLA
E3-02	Max Frequency	E4-02	Motor Rated Slip
E3-03	Max Voltage	E4-03	No-Load Current
E3-04	Base Frequency	E4-04	Number of Motor Poles
E3-05	Mid Frequency	E4-05	Terminal Resistance
E3-06	Mid Voltage	E4-06	Leakage Inductance
E3-07	Min Frequency	E4-07	Motor Rated Power
E3-08	Min Voltage	-	-

■ **E3-02 Motor 2 Maximum Output Frequency**

Setting Range: 0.0 to 400.0 Hz

Factory Default: 60.0 Hz

■ **E3-03 Motor 2 Maximum Output Voltage**

Setting Range: 0.0 to 255.0V (240V Models)

0.0 to 510.0V (480V Models)

Factory Defaults: 230.0V (240V Models)

480.0V (480V Models)

■ **E3-04 Motor 2 Base Frequency**

Setting Range: 0.0 to 400.0 Hz

Factory Default: 60.0 Hz

■ E3-05 Motor 2 Mid Output Frequency A

Setting Range: 0.0 to 400.0 Hz
Factory Default: 3.0 Hz

■ E3-06 Motor 2 Mid Output Voltage VA

Setting Range: 0.0 to 255.0V (240V Models)
0.0 to 510.0V (480V Models)

Factory Defaults: 12.6V (240V Models)
25.2V (480V Models)

■ E3-07 Motor 2 Minimum Output Frequency

Setting Range: 0.0 to 400.0 Hz
Factory Default: 0.5 Hz

■ E3-08 Motor 2 Minimum Output Voltage

Setting Range: 0.0 to 255.0V (240V Models)
0.0 to 510.0V (480V Models)

Factory Defaults: 2.3V (240V Models)
4.6V (480V Models)

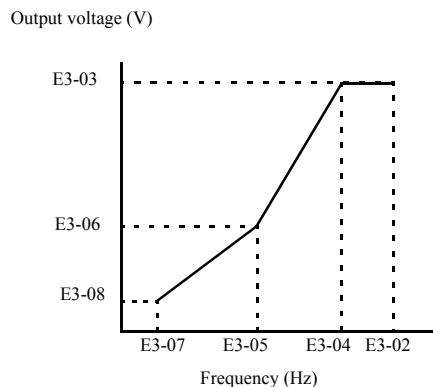

Fig. 40 Motor 2 V/f Curve

To set V/f characteristics in a straight line, set the same values for E3-05 and E3-07. In this case, the setting for E3-06 will be disregarded. Be sure that the four frequencies are set in the following manner or else an OPE10 fault will occur:

$$E3-07 \leq E3-05 < E3-04 \leq E3-02$$

◆ E4 Motor Setup 2

■ E4-01 Motor 2 Rated Current

Setting Range: Model Dependent
Factory Default: Model Dependent

The Motor Rated Current parameter (E2-01) is used by the Drive to protect the motor and for proper Vector control when using Open Loop Vector or Flux Vector control methods (E3-01 = 2 or 3). The motor protection parameter L1-01 is enabled by default. Set E2-01 to the full load amps (FLA) stamped on the motor's nameplate.

During Auto-tuning, it is required for the operator to enter the motor's rated current (T1-04) in the Auto-Tuning menu. If the Auto-tuning operation completes successfully (T1-02 = 0), the value entered into T1-04 will automatically be written into E4-01.

■ E4-02 Motor 2 Rated Slip

Setting Range: Model Dependent

Factory Default: Model Dependent

This parameter sets the motor rated slip frequency in units of 0.01Hz. If the rotational Auto-tuning operation completes successfully, this value is automatically calculated. The default setting varies depending on the drive model number (o2-04). The following equation to calculate the motor rated slip frequency based on motor nameplate data:

$$f_s = f - \frac{(N \cdot P)}{120}$$

where:

f_s : slip frequency (Hz)

f : rated frequency (Hz)

N : rated motor speed (rpm)

P : number of motor poles

■ E4-03 Motor 2 No Load Current

Setting Range: Model Dependent

Factory Default: Model Dependent

Set E4-03 to the motor no-load current at rated voltage and rated frequency. If the rotational Auto-tuning operation completes successfully (T1-02 = 0), this value is automatically calculated. Consult the motor manufacturer for the proper value if the no load current is not stated on the motor nameplate.

■ E4-04 Motor 2 Number of Poles

Setting Range: 2 to 48

Factory Default: 4

This parameter sets the number of motor poles. During auto-tuning, it is required for the operator to enter the number of motor poles (T1-06) in the Auto-Tuning menu. If the Auto-tuning operation completes successfully (T1-02 = 0, 1, or 2), the value entered into T1-06 will automatically be written into E4-04.

■ E4-05 Motor 2 Line-to-Line Resistance

Setting Range: 0.0000to 65.000 Ω

Factory Default: 9.842 Ω

Sets the line-to-line resistance of the motor's stator winding. If the Auto-tuning operation completes successfully (T1-02 = 0, 1, or 2), this value is automatically calculated. Remember this value must be entered as line-line and not line neutral.

$$E2-05 = \left(\frac{\text{Phase-to-phase Resistance at}}{\text{Insulation Class Temperature}} \right) \times \frac{273 + (25 + \text{insulation class temperature}) / 2}{273 + \text{insulation class temperature}}$$

Where: Insulation class temperature is in °C

■ E4-06 Motor 2 Leakage Inductance

Setting Range: 0.0 to 40.0 %
Factory Default: Model Dependent

Sets the voltage drop due to motor leakage inductance as a percentage of motor rated voltage. If the rotational Auto-tuning operation completes successfully (T1-02 = 0), this value is automatically calculated.

■ E4-07 Motor Rated Output

Setting Range: 0.00 to 650.00 kW
Factory Default: Model Dependent

This parameter sets the motor rated power in kilowatts (kW). If the rotational Auto-tuning operation completes successfully (T1-02 = 0), this value is automatically calculated.

◆ F1 PG Option Setup

■ F1-01 PG Pulses / Revolution

Setting Range: 0 to 60000
Factory Default: 1024

This parameter sets the number of PG pulses per one revolution of the encoder (pulse generator) when using PG option board on the Drive.

■ F1-02 Operation Selection at PG Open Circuit (PGO)

Setting	Description
0	Ramp to Stop - Decelerate to stop using active deceleration time.
1	Coast to Stop (<i>factory default</i>)
2	Fast-stop - Decelerate to stop using the deceleration time in C1-09.
3	Alarm Only - Drive continues operation.

This parameter sets the stopping method when a PG open circuit fault (PGO) occurs according to the PGO detection time set in parameter F1-14.

■ F1-03 Operation Selection at Overspeed (OS)

Setting	Description
0	Ramp to Stop - Decelerate to stop using active deceleration time.
1	Coast to Stop (<i>factory default</i>)
2	Fast-stop - Decelerate to stop using the deceleration time in C1-09.
3	Alarm Only - Drive continues operation.

This parameter sets the stopping method when an overspeed fault (OS) occurs according to the OS detection level and detection time set in parameter F1-08 and F1-09, respectively.

■ F1-04 Operation Selection at Speed Deviation (DEV)

Setting	Description
0	Ramp to Stop - Decelerate to stop using active deceleration time.
1	Coast to Stop
2	Fast-stop - Decelerate to stop using the deceleration time in C1-09.
3	Alarm Only - Drive continues operation. (<i>factory default</i>)

This parameter sets the stopping method when a speed deviation fault (DEV) occurs according to the OS detection level and detection time set in parameter F1-08 and F1-09, respectively.

■ F1-05 PG Rotation Selection

Setting	Description
0	Forward = Counter Clock-wise - Phase A leads with forward run command. (<i>factory default</i>)
1	Forward = Clock-wise - Phase B leads with forward run command.

This parameter sets the relationship between motor rotation direction and PG polarity. The motor rotation direction applies when viewing the motor shaft from the load side.

■ F1-05 PG Division Rate

Setting Range: 1 to 132

Factory Default: 1

This parameter sets the division ratio for the pulse monitor of the PG-B2 encoder feedback option board. This function is not available with the PG-X2 option board.

$$\text{Division Ratio} = (1 + n) / m$$

where $n = 0$ to 1 and $m = 1$ to 32

The first digit of the value of F1-06 stands for n , the second and the third digit stand for m (from left to right).

Example:

$$\text{F1-05} = \underset{\substack{\nearrow \\ n = 1}}{1} \underset{\substack{\nwarrow \\ m = 16}}{16}$$

$$\text{Division Ratio} = (1 + 1) / 16 = 0.125$$

The possible division ratio settings are:

$$1/32 \leq \text{F1-06} \leq 1$$

■ F1-07 Integral Function During Accel / Decel Selection

Setting	Description
0	Disable - Integral function is not used during accel or decel. (<i>factory default</i>)
1	Enable - Integral function is used at all times.

This parameter enables or disables the speed control (ASR) integral operation during acceleration or deceleration.

■ F1-08 Overspeed Detection Level

Setting Range: 0 to 120 %

Factory Default: 115 %

■ F1-09 Overspeed Detection Delay Time

Setting Range: 0.0 to 2.0 seconds
 Factory Default: 0.0 seconds

Parameter F1-08 sets the motor overspeed detection level as a percentage of maximum output frequency (E1-04) for the over-speed fault (OS). Parameter F1-09 sets the elapsed time from when an overspeed condition is detected to when a fault occurs. See figure below.

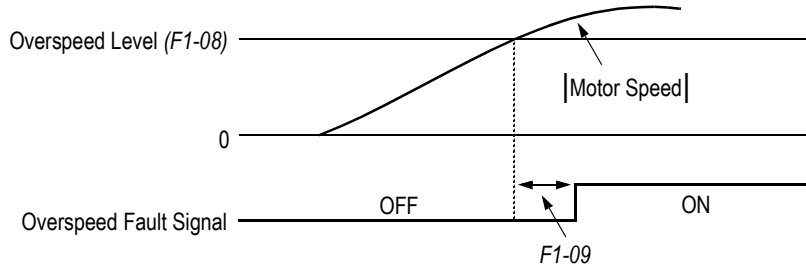

Fig. 41 Overspeed Detection Timing Diagram

A fault signal is output to stop operation after the absolute value of the motor speed exceeds the set value of F1-08 and after the time set to F1-09 elapses. The stopping method is set by F1-03. When parameter A1-02 = 1 (V/f with PG) the factory default setting will be 1.0. When parameter A1-02 = 3 (Flux Vector) the factory setting will be 0.0.

■ F1-10 Excessive Speed Deviation Detection Level

Setting Range: 0 to 50 %
 Factory Default: 10 %

■ F1-11 Excessive Speed Deviation Detection Delay Time

Setting Range: 0.0 to 10.0 seconds
 Factory Default: 0.5 seconds

Parameter F1-10 sets the speed deviation detection level as a percentage of maximum output frequency (E1-04) for the speed deviation fault (DEV). Parameter F1-11 sets the elapsed time from when an speed deviation condition is detected to when a fault occurs. See figure below.

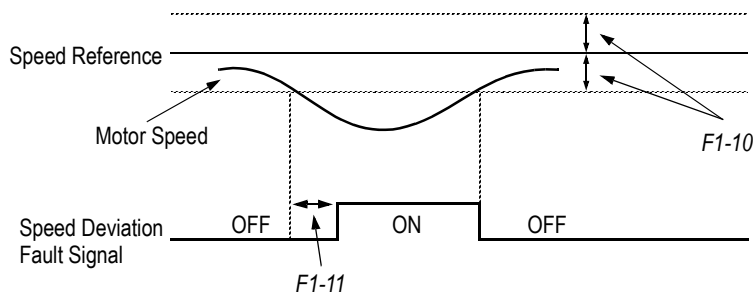

Fig. 42 Speed Deviation Detection Timing Diagram

A fault signal is output to stop operation after the deviation between speed reference and the motor speed exceeds the set value of F1-10 and after the time set to F1-11 elapses. The stopping method is set by F1-04. Also, detection is not activated while accelerating/decelerating or during torque control.

■ F1-12 Number of PG Gear Teeth 1

■ F1-13 Number of PG Gear Teeth 2

Setting Range: 0 to 1000

Factory Default: 0

Parameter F1-12 and F1-13 sets the gear ratio between the motor shaft and the encoder (PG) according to the following formula:

$$\text{No. of Motor RPM's} = \frac{\text{No. of PG Output Pulses} \times 60}{\text{PG Pulses/Revolution (F1-01)}} \times \frac{\text{No. of Teeth Gear 2 (F1-13)}}{\text{No. of Teeth Gear 1 (F1-12)}}$$

A gear ratio of 1 will be used if either of these parameters is set to zero. This function is not available in Flux Vector control (A1-02 = 3).

■ F1-14 PG Open-Circuit (PGO) Detection Time

Setting Range: 0.0 to 10.0 seconds

Factory Default: 2.0 seconds

Parameter F1-14 sets the time from when the pulse generator (PG) signal is missing to when the fault signal is displayed on the Drive. The stopping method when a “PGO” fault is detected is selected by parameter F1-02. If a speed reference is commanded, but the motor is physically locked, a “PGO” fault will occur even though the PG is connected to the Drive.

◆ F2 AI-14 Setup

■ F2-01 AI-14 Input Selection

Setting	Description
0	3-Channel Individual (channel 1: terminal A1, channel 2: terminal A2, channel 3: terminal A3) (<i>factory default</i>)
1	3-Channel Addition (Summed values of channels 1, 2, and 3 is the frequency reference)

This parameter selects the function for channel 1, 2, and 3 when AI-14B analog input reference option board is used.

When the 3-channel individual input is used, parameter b1-01 is automatically set to “1” (frequency reference from control circuit terminal). The option/inverter reference selection, which is selected by a multi-function contact input (H1-0x = “2”), is disabled when using the AI-14B option.

◆ F3 DI-08, 16 Setup

■ F3-01 DI-08 / DI-16H2 Input Selection

Setting	Description
0	BCD 1% Unit (<i>factory default</i>)
1	BCD 0.1% Unit
2	BCD 0.01% Unit
3	BCD 1Hz. Unit
4	BCD 0.1Hz. Unit
5	BCD 0.01Hz Unit
6	BCD (5-digit) 0.01 Hz. Unit (for DI-16H2 only)
7	Binary Input

This parameter sets the function of the DI-08 or the DI-16H2 digital input option board. When o1-03 is set to 2 or higher, the input will be BCD, and the units will change to the o1-03 setting.

◆ F4 AO-08, 12 Setup

■ F4-01 AO-08 / AO-12 Channel 1 Monitor Selection

Setting Range: 1 to 45
Factory Default: 2

This parameter sets the number of the monitor item to be output (U1-0x) for channel 1 of the AO-08 or AO-12 analog output option board. The following settings cannot be set:
4, 10 to 14, 25, 28, 29, 31, 34, 39, 40, 41.

■ F4-02 AO-08 / AO-12 Channel 1 Gain

Setting Range: 0.0 to 1000.0 %
Factory Default: 100.0 %

This parameter sets the gain for channel 1 of the AO-08 or AO-12 analog output option board.
Example: Set F4-02 = 50 % to output 100% at 5.0 Volts.

■ F4-03 AO-08 / AO-12 Channel 2 Monitor Selection

Setting Range: 1 to 45
Factory Default: 2

This parameter sets the number of the monitor item to be output (U1-xx) for channel 2 of the AO-08 or AO-12 analog output option board. The following settings cannot be set:
4, 10 to 14, 25, 28, 29, 31, 34, 39, 40, 41.

■ F4-04 AO-08 / AO-12 Channel 2 Gain

Setting Range: 0.0 to 1000.0 %
Factory Default: 100.0 %

This parameter sets the gain for channel 2 of the AO-08 or AO-12 analog output option board.
Example: Set F4-02 = 50 % to output 100% at 5.0 Volts.

■ F4-05 AO-08 / AO-12 Channel 1 Output Bias

■ F4-06 AO-08 / AO-12 Channel 2 Output Bias

Setting Range: -110.0 to 110.0 %
Factory Default: 0.0 %

Parameters F4-05 and F4-06 respectively set channel 1 and channel 2 bias of the AO-08 or AO-12 analog output option board.
Example: Set F4-05 = 50% to output 0% at 5.0V output.

■ F4-07 AO-12 Channel 1 Signal Level

■ F4-08 AO-12 Channel 2 Signal Level

Setting	Description
0	0 to 10 Vdc (<i>factory default</i>)
1	-10 to +10 Vdc

Parameters F4-07 and F4-08 respectively set channel 1 and channel 2 signal level of the AO-12 analog output option board.

◆ F5 DO-02, 08 Setup

■ F5-01 DO-02 / DO-08 Channel 1 Output Selection

Setting Range: 0 to 38
Factory Default: 0

■ F5-02 DO-02 / DO-08 Channel 2 Output Selection

Setting Range: 0 to 38
Factory Default: 1

■ F5-03 DO-08 Channel 3 Output Selection

Setting Range: 0 to 38
Factory Default: 2

■ F5-04 DO-08 Channel 4 Output Selection

Setting Range: 0 to 38
Factory Default: 4

■ F5-05 DO-08 Channel 5 Output Selection

Setting Range: 0 to 38
Factory Default: 6

■ F5-06 DO-08 Channel 6 Output Selection

Setting Range: 0 to 38
Factory Default: 37

■ F5-07 DO-08 Channel 7 Output Selection

Setting Range: 0 to 38
Factory Default: F

■ F5-08 DO-08 Channel 8 Output Selection

Setting Range: 0 to 38
Factory Default: F

These parameters set the digital output function number for channel 1 when digital output DO-02 or DO-08 option board is used. See H2 parameter group for possible selections.

Parameters F5-01 and F5-02 set the digital output function number for channel 1 and 2, respectively when DO-02 or DO-08 digital output option board is used.

Parameters F5-03 to F5-08 set the digital output function number for channels 3 to 8 when DO-08 digital output option board is used.

■ F5-09 DO-08 Output Mode Selection

Setting	Description
0	8-Channel Individual Outputs (<i>factory default</i>)
1	Binary Code Output
2	8-Channel Selected - output according to F5-01 to F5-08 settings

This parameter sets the function of the DO-08 digital output option board.

◆ F6 Communication Option Setup

■ F6-01 Operation Selection After Communication Error

Setting	Description
0	Ramp to Stop
1	Coast to Stop (<i>factory default</i>)
2	Fast-Stop
3	Alarm Only

If a communication option board is attached to the Drive at the 2CN connector, the Drive will automatically monitor the card for any type of communication errors. F6-01 is applicable no matter whether a run command or frequency reference is coming via the option board, digital operator, or terminal input. The setting of F6-01 determines whether the communication error is seen as a fault or an alarm. If F6-01=“3: Alarm Only”, then the fault output is not energized upon a communication error. All other settings of F6-01 cause the fault output to energize. The setting of F6-01 does not apply to any of the embedded communication protocols used at the RS-485/422 terminals on the removable terminal board.

■ F6-02 Option PCB External Fault Detection Selection

Setting	Description
0	Always Detected (<i>factory default</i>)
1	Detected only during operation

■ F6-03 Option PCB External Fault stopping Method

Setting	Description
0	Ramp to Stop
1	Coast to Stop (<i>factory default</i>)
2	Fast-Stop
3	Alarm Only

If an external fault is received from the communication option board, the settings of F6-02 and F6-03 will determine the Drive operation in reaction to the fault signal. Parameter F6-02 will determine if the external fault is always recognized (F6-02=“0: Always Detected”) or only recognized when the Run command is active (F6-02=“1: Detected only during operation”). Once the fault is recognized, parameter F6-03 will determine the operation of the Drive. If parameter F6-03 is set to anything other than “3”, the Drive will fault and a stopping sequence is begun. If F6-03=“3: Alarm Only”, then the external fault is treated like an alarm. Operation will continue and an EF0 fault will flash on the digital operator.

■ F6-04 Trace Sampling from Communication Option Board

Setting Range: 0 to 60000

Factory Default: 0

This parameter sets the sample trace for the CP-916 option board.

■ F6-05 Current Scaling via Communication Option PCB

Setting	Description
0	Displayed in Amps (<i>factory default</i>)
1	100%/8192 (12-bit binary number with 8192 = 100% Drive Rated Current)

A communication option card can read the Drive's DPRAM to access the current monitor. The format of the current reading in the DPRAM will be determined by parameter F6-05.

F6-05= "0: A Display" → Current is a decimal number corresponding to actual Amperes

F6-05= "1: 100%/8192 (Drive Rated Current)" → Current reading is a number where
8192 = 100% of Drive rated output current

■ F6-06 Torque Reference / Limit Selection from Communications Option Board

Setting	Description
0	Disabled - torque reference / limit from option board disabled
1	Enabled - torque reference / limit from option board enabled (<i>factory default</i>)

This parameter allows the torque reference and/or torque limit to come from the communications option board.

◆ H1 Digital Inputs

■ H1-01 Terminal S3 Function Selection

H1-02 Terminal S4 Function Selection

H1-03 Terminal S5 Function Selection

H1-04 Terminal S6 Function Selection

H1-05 Terminal S7 Function Selection

H1-06 Terminal S8 Function Selection

Setting Range: 0 to 78

Factory Default: H1-01= "24: External Fault"

H1-02= "14: Fault Reset"

H1-03= "3: Multi-Step Ref 1" (2-Wire)

"0: 3-Wire Control" (3 Wire)

H1-04= "4: Multi-Step Ref 2" (2 Wire)

"3: Multi-Step Ref 1" (3 Wire)

H1-05= "6: Jog Freq Ref" (2 Wire)

"4: Multi-Step Ref 2" (3 Wire)

H1-06= "8: External BaseBlock N.O."

The Drive has 6 multi-function contact digital inputs. By programming parameters H1-01 through H1-06, the user can assign specific functions to each input. Below is a table with a complete list of all of the digital input functions according to control method (A1-02). Not all functions are available for all control methods. Following the table is a more detailed description of each of the functions.

Table 13 Multi-Function Input Selection					
Parameter Setting	Function	Control Method (A1-02)			
		V/f	V/f with PG	Open Loop Vector	Flux Vector
0	3-Wire Control	0	0	0	0
1	Local/Remote Selection	0	0	0	0
2	Option/Inverter Selection	0	0	0	0
3	Multi-Step Frequency Reference 1 (<i>factory default, H1-03</i>)	0	0	0	0
4	Multi-Step Frequency Reference 2 (<i>factory default, H1-04</i>)	0	0	0	0
5	Multi-Step Frequency Reference 3	0	0	0	0
6	Jog Frequency Reference (<i>factory default, H1-05</i>)	0	0	0	0
7	Accel/Decel Time Selection 1	0	0	0	0
8	External Baseblock N.O. (<i>factory default, H1-06</i>)	0	0	0	0
9	External Baseblock N.C.	0	0	0	0
A	Accel/Decel Ramp Hold	0	0	0	0
B	External Overheat Alarm (OH2)	0	0	0	0
C	Terminal A2 Enable	0	0	0	0
D	V/f Control with PG Disabled	X	0	X	X
E	ASR Integral Reset	X	0	X	0
F	Terminal Not Used	0	0	0	0
10	MOP Increase	0	0	0	0
11	MOP Decrease	0	0	0	0
12	Forward Jog	0	0	0	0
13	Reverse Jog	0	0	0	0
14	Fault Reset (<i>factory default, H1-02</i>)	0	0	0	0
15	Fast-Stop N.O.	0	0	0	0
16	Motor 2 Selection	0	0	0	0
17	Fast-Stop N.C.	0	0	0	0
18	Timer Function	0	0	0	0
19	PID Disable	0	0	0	0
1A	Accel/Decel Time Selection 2	0	0	0	0
1B	Program Lockout	0	0	0	0
1C	Trim Control Increase	0	0	0	0
1D	Trim Control Decrease	0	0	0	0
1E	Reference Sample Hold	0	0	0	0
20	External Fault, Normally Open, Always Detected, Ramp To Stop	0	0	0	0
21	External Fault, Normally Closed, Always Detected, Ramp To Stop	0	0	0	0
22	External Fault, Normally Open, During Run, Ramp To Stop	0	0	0	0
23	External Fault, Normally Closed, During Run, Ramp To Stop	0	0	0	0
24	External Fault, Normally Open, Always Detected, Coast to Stop (<i>factory default, H1-01</i>)	0	0	0	0
25	External Fault, Normally Closed, Always Detected, Coast To Stop	0	0	0	0
26	External Fault, Normally Open, During Run, Coast To Stop	0	0	0	0
27	External Fault, Normally Closed, During Run, Coast To Stop	0	0	0	0
28	External Fault, Normally Open, Always Detected, Fast-Stop	0	0	0	0
29	External Fault, Normally Closed, Always Detected, Fast-Stop	0	0	0	0
2A	External Fault, Normally Open, During Run, Fast-Stop	0	0	0	0
2B	External Fault, Normally Closed, During Run, Fast-Stop	0	0	0	0
2C	External Fault, Normally Open, Always Detected, Alarm Only	0	0	0	0
2D	External Fault, Normally Closed, Always Detected, Alarm Only	0	0	0	0
2E	External Fault, Normally Open, During Run, Alarm Only	0	0	0	0
2F	External Fault, Normally Closed, During Run, Alarm Only	0	0	0	0
30	PID Integral Reset	0	0	0	0
31	PID Integral Hold	0	0	0	0
32	Multi-Step Reference 4	0	0	0	0
34	PID Soft Starter Cancel	0	0	0	0

Table 13 Multi-Function Input Selection (Continued)					
Parameter Setting	Function	Control Method (A1-02)			
		V/f	V/f with PG	Open Loop Vector	Flux Vector
35	PID Input (Error) Polarity Change	O	O	O	O
60	DC Injection Braking	O	O	O	O
61	Speed Search 1	O	X	O	X
62	Speed Search 2	O	X	O	X
63	Field Weakening Command (Energy Savings)	O	O	X	X
64	Speed Search 3	O	O	O	O
65	Kinetic Energy Braking Ridethru N.C.	O	O	O	O
66	Kinetic Energy Braking Ridethru N.O	O	O	O	O
67	Communication Test Mode	O	O	O	O
68	High Slip Braking	O	O	X	X
69	Jog 2	O	O	O	O
6A	Drive Enable	O	O	O	O
71	Speed/Torque Control Selection	X	X	X	O
72	Zero Servo Command	X	X	X	O
77	ASR Gain Switch	X	X	X	O
78	Polarity Reversing Command for External Torque Control	X	X	X	O

Function: 3-Wire Control

Setting: 0

When one of the digital inputs is programmed for 3-Wire control, that input becomes a Forward/Reverse directional input. Whenever the input is open, the Drive will be set for forward rotation of the motor shaft. If the input is closed, then the motor shaft will rotate in the reverse direction whenever there is a Run input. The S1 and S2 digital inputs will function as a Run and Stop input respectively.

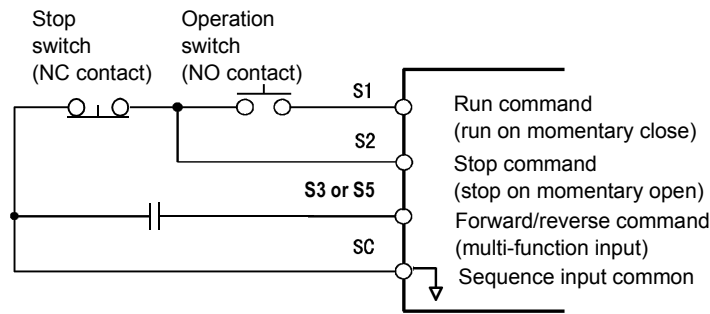

Fig. 43 Terminal Configuration for 3-Wire Control

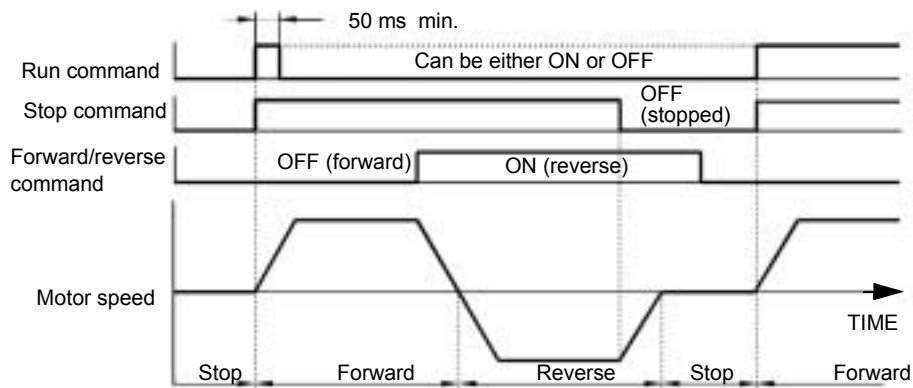

Fig. 44 3-Wire Control Timing Diagram

IMPORTANT

As long as the S1(Run Command) input is applied in for at least 50 ms the Run command will latch internally in the Drive.

Function: Local/Remote Selection**Setting: 1**

Selects the operation mode, only when the Drive is stopped.

Local: Operation according to frequency reference and run command from digital operator.

Remote: Operation according to frequency reference and run command set by parameter b1-01 and b1-02, respectively.

Note: When local/remote selection is set by a multi-function contact input terminal, LOCAL/REMOTE key on the digital operator key is disabled.

Function: Option/Inv Selection 1**Setting: 2**

The Option/Inv Selection function allows the user to select the source for the Run and frequency references between either the Drive's terminals or an optional communication board. When a digital input is programmed for the Option/Inv Selection function (H1-0x= 2) that input will function as follows:

Table 14 Digital Input Functions	
Option/Inv Selection Input Status	Run and frequency reference Source
OPEN	From the control circuit and analog input terminals
CLOSED	From the Communications Option Board

To switch the command source between the option card and the terminals be sure to program the following parameters:

- Set b1-01 (Frequency Reference Selection) to 1 (Terminals).
- Set b1-02 (Run Command Selection) to 1 (Terminals).
- Set H1-0x (Input Terminal Function Selection) to 2.

IMPORTANT

Switching between the different Reference and Run sources can only be done while the Drive is stopped.

Function: Multi-step Reference 1**Setting: 3****Function: Multi-step Reference 2****Setting: 4****Function: Multi-step Reference 3****Setting: 5**

The Drive can be programmed to utilize digital inputs to change between 16 presets speeds and a jog speed. It is a two-step process to set the Drive up for preset speeds. First, d1-01 through d1-16 and d1-17 must be programmed with the desired pre-set speeds and the desired jog speed, respectively. Next, up to four terminals S3 through S8 need to be programmed (via parameters H1-01 to H1-06) and wired (to normally open contacts) as “3: Multi-step Speed Reference 1”, “4: Multi-step Speed Reference 2”, “5: Multi-step Speed Reference 3”, “6: Multi-step Speed Reference 4”, and “7: Jog Frequency”.

The following table details which reference is active based on the status of the Multi-step Ref 1 and Multi-step Ref 2 inputs:

Preset Speed	Multi-step Reference 1	Multi-step Reference 2	Multi-step Reference 3	Multi-step Reference 4	Jog Reference	Details
1	OFF	OFF	OFF	OFF	OFF	Frequency Reference 1 (d1-01) or Analog Input A1
2	ON	OFF	OFF	OFF	OFF	Frequency Reference 2 (d1-02) or Analog Input A2
3	OFF	ON	OFF	OFF	OFF	Frequency Reference 3 (d1-03)
4	ON	ON	OFF	OFF	OFF	Frequency Reference 4 (d1-04)
5	OFF	OFF	ON	OFF	OFF	Frequency Reference 5 (d1-05)
6	ON	OFF	ON	OFF	OFF	Frequency Reference 6 (d1-06)
7	OFF	ON	ON	OFF	OFF	Frequency Reference 7 (d1-07)
8	ON	ON	ON	OFF	OFF	Frequency Reference 8 (d1-08)
9	OFF	OFF	OFF	ON	OFF	Frequency Reference 9 (d1-09)
10	ON	OFF	OFF	ON	OFF	Frequency Reference 10 (d1-10)
11	OFF	ON	OFF	ON	OFF	Frequency Reference 11 (d1-11)
12	ON	ON	OFF	ON	OFF	Frequency Reference 12 (d1-12)
13	OFF	OFF	ON	ON	OFF	Frequency Reference 13 (d1-13)
14	ON	OFF	ON	ON	OFF	Frequency Reference 14 (d1-14)
15	OFF	ON	ON	ON	OFF	Frequency Reference 15 (d1-15)
16	ON	ON	ON	ON	OFF	Frequency Reference 16 (d1-16)
JOG	-	-	-	-	ON*	Jog Frequency (d1-17)

* The Jog Frequency input is given priority over the multi-step speeds.

The determination of whether the Preset Speed 1 will be the Frequency Reference 1 (d1-01 or the analog input A1) is determined by the status of b1-01. If b1-01= “1: Terminals”, the value of the input to A1 will determine the commanded speed when Preset Speed 1 is selected. If b1-01≠1, the setting of d1-01 will determine the commanded speed when Preset Speed 1 is selected.

The determination of Preset Speed 2 is made much the same way as Preset Speed 1 except that the setting of parameter H3-09 decides whether the analog input A2 or d1-02 is Preset Speed 2. If H3-09= “2: Aux Reference”, the value of the input to A2 will determine the commanded speed when Preset Speed 2 is selected. If H3-09≠2, the setting of d1-02 will determine the commanded speed when Preset Speed 2 is selected.

Function: Jog Frequency Reference

Setting: 6

When a digital input configured as Jog Freq Ref (H1-0x= 6) is Closed, the active frequency reference will be the setting of parameter d1-17 (Jog Frequency Reference). Closure of this digital input alone will not initiate a Jog motion, it will only change the frequency reference. An active Run input is necessary for actual jogging.

To change to the Jog frequency reference and provide a Run Command, with a single input, please refer to digital input settings “12” and “13”.

Function: Multi-Acceleration/Deceleration 1

Setting: 7

When any of the multi-function contact input selections (H1-01 to H1-06) are set to “7” and “1A”, up to four accel/decel times can then be selected by opening or closing the appropriate accel/decel time selection commands (terminals 3 to 8).

Accel/decel Time Selection 1 Multi-function Input Setting = "7"	Accel/decel Time Selection 2 Multi-function Input Setting = "1A"	Accel Time	Decel Time
Open or not set	Open or not set	C1-01	C1-02
Closed	Open or not set	C1-03	C1-04
Open or not set	Closed	C1-05	C1-06
Closed	Closed	C1-07	C1-08

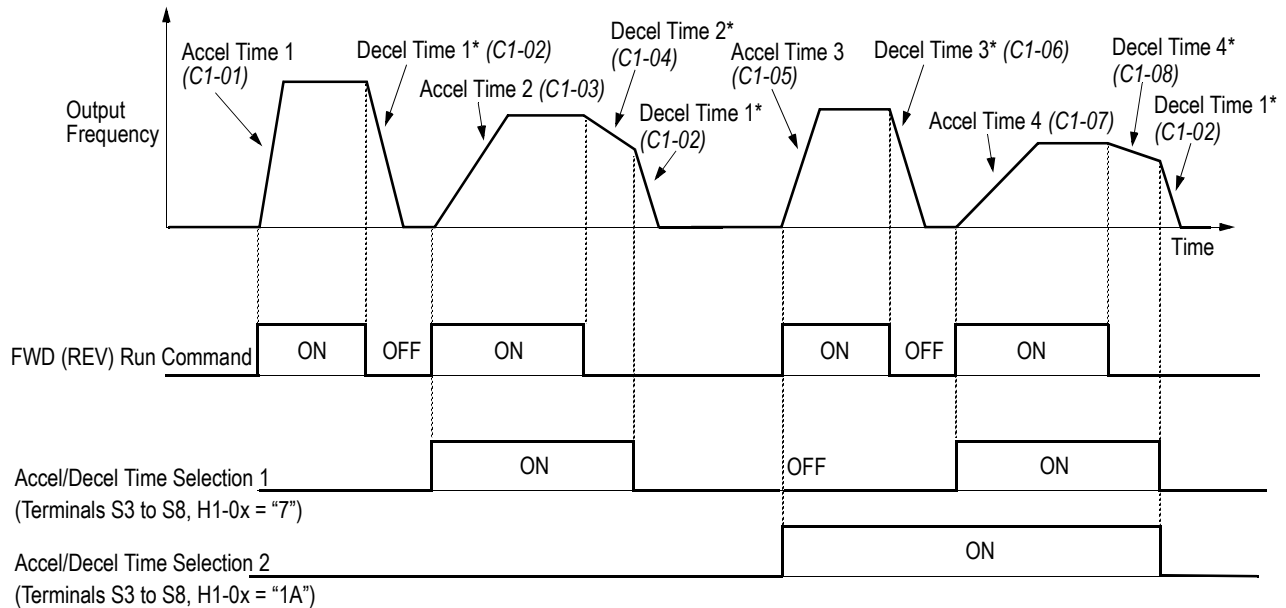

* When "deceleration to stop" is selected (B1-03 = "0")

Fig. 45 Timing Diagram of Accel / Decel Time Change

Function: External Baseblock N.O.

Setting: 8

Function: External Baseblock N.C.

Setting: 9

When the Drive is commanded into baseblock, gating of the output transistor stops and output voltage/frequency drops to zero (motor coasts). The Drive can be forced into a baseblock state by either closing a digital input configured for Ext Baseblk N.O. (H1-0x= 8) or opening a digital input configured for Ext Baseblk N.C. (H1-0x= 9).

When the baseblock state is removed the speed search function is used to catch the coasting motor and ramp it back to the commanded speed.

The method of speed search, Current Detection or Speed Estimation, that is utilized when the baseblock input is removed depends on the setting of parameter b3-01:

If b3-01= "0: SpdsrchF Disable" or "1: SpdsrchF Enable"; Speed Estimation is used

If b3-01= "2: SpdsrchI Disable" or "3: SpdsrchF Enable"; Current Detection is used

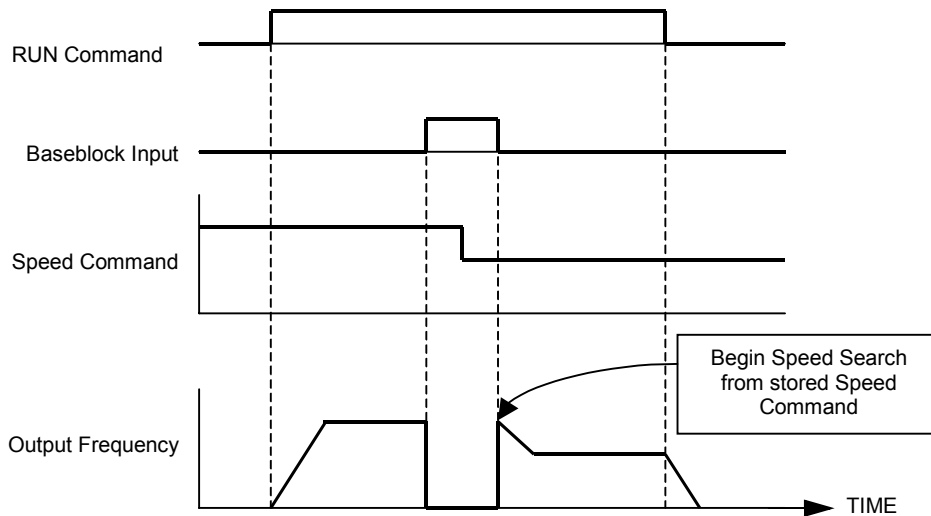

Fig. 46 External Baseblock Characteristics

Function: Acceleration/Deceleration Ramp Hold

Setting: A

The Acc/Dec Ramp Hold function will clamp (“hold”) the speed of the output frequency whenever a digital input that has been programmed for it (H1-0x= A) is closed. All acceleration or deceleration will stop and the Drive will hold the current speed. Once the input is opened, acceleration or deceleration continues.

The Acc/Dec Ramp Hold function is affected by parameter d4-01. If d4-01= “1: Enabled” and the Acc/Dec Ramp Hold functions are both being used, whenever the Ramp Hold input is closed the output frequency is memorized. When interrupted power is returned and a Run command is input, the frequency reference will be the last output frequency memorized by the Acc/Dec Ramp Hold function, if the Acc/Dec Ramp Hold input is still closed.

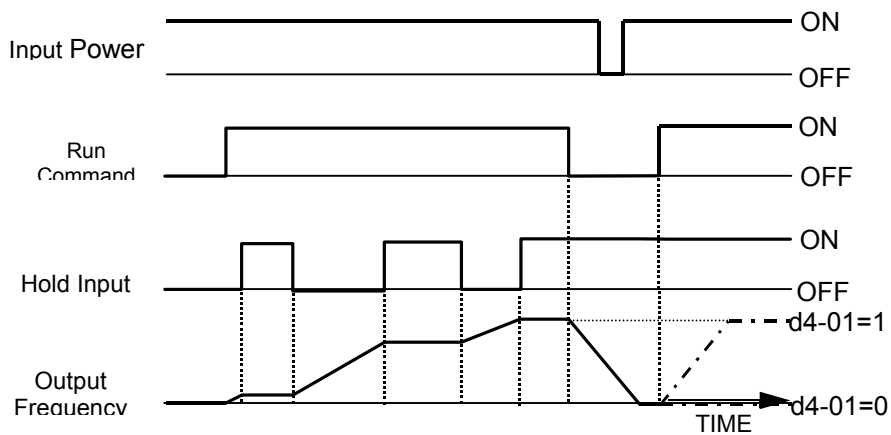

Fig. 47 Accel/Dec Ramp Hold Function Timing Diagram

Function: Terminal A2 Enable

Setting: C

Any digital input configured as Term A2 Enable (H1-0x= C) when open will cause the input to analog input A2 to be ignored. If analog input A2 is configured as the Main Reference (H3-13= “1: Main Fref TA1”), then the Term A2 Enable input will have no effect.

Function: V/f Control with PG Disabled**Setting: D**

PG feedback input can be disabled while the Drive is running when this function is selected. However, the speed control integral value (C5-05) is held until the run command is removed.

- Open: PG feedback control enabled (closed loop)
- Closed: PG feedback control disabled (open loop)

This function is available only during V/f control with PG feedback (A1-02 = 1).

Function: Terminal Not Used**Setting: F**

Any digital input programmed as Term Not Used (H1-0x= F) will have no function assigned to it and its OPEN/CLOSED state will not matter to the Drive's operation.

Function: MOP Increase**Setting: 10****Function: MOP Decrease****Setting: 11**

Using two digital inputs, the Drive can operate with the same type of functionality as a motor operated potentiometer (MOP). One digital input can be programmed as an MOP Increase input (H1-0x= 10) and another digital input can be programmed as an MOP Decrease input (H1-0x= 11). This MOP functionality is also commonly referred to as Floating Point Control, Incremental Control or UP and DOWN Control since closing the MOP Increase input will cause the frequency reference to increase and closing the MOP Decrease input will cause the frequency reference to decrease.

If both the MOP Increase and the MOP Decrease are closed or open simultaneously, the speed will command will not change. The frequency reference will change at the active acceleration or deceleration rate.

MOP Increase cannot be programmed without also programming the MOP Decrease (or vice-versa) else an OPE03 fault will occur. Setting the MOP Increase/Decrease function while the Acc/Dec Ramp Hold function is programmed into other digital inputs will also cause an OPE03 fault.

Once the MOP function is programmed the preset speeds are disabled and the analog frequency reference input becomes a potential frequency reference lower limit. The lower limit of the MOP function is the greater of the analog frequency reference and the programmed frequency reference lower limit (d2-03). Once a Run command is issued the Drive will accelerate immediately to the lower limit. The upper limit will be the Frequency Reference Upper Limit (d2-01), if used, otherwise it will be the maximum output frequency (E1-04).

The status of the d4-01 parameter (MOP Reference Memory) will affect the performance of the Drive after power is cycled to the Drive and a fresh Run command is issued. If d4-01= "0: Disabled", the Run command will cause the Drive to ramp to the frequency reference lower limit. However, if d4-01= "1: Enabled", the Run command will cause the Drive to ramp to the last frequency referenced by the MOP function before the Run command was removed and the power cycled. Even if d4-01= "1: Enabled", the previous frequency reference can be reset to the frequency reference lower limit automatically by closing either the UP or Down input without having a Run command active.

IMPORTANT

Be sure to set b1-01= "1: Terminals", (frequency reference Source =Terminals) if the MOP function is to be used. If b1-01= "0: Operator", then the MOP is disabled even if it is programmed. The Jog inputs have priority over the MOP function.

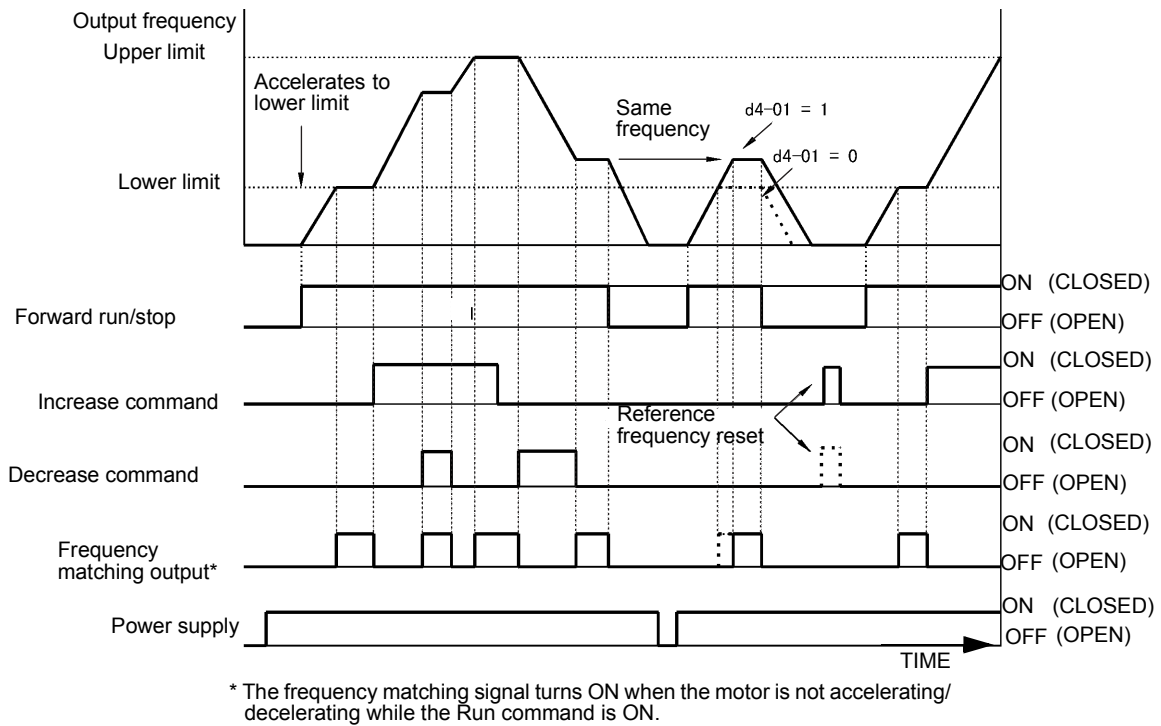

Fig. 48 Floating Point Control Time Chart

Function: Forward Jog

Setting: 12

Function: Reverse Jog

Setting: 13

Digital inputs programmed as Forward Jog (H1-0x= 12) and Reverse Jog (H1-0x= 13) will be Jog inputs that do not require a Run command. Closing the Forward Jog input will cause the Drive to ramp to the Jog Frequency Reference (d1-17) in the Fwd direction. The Reverse Jog will cause the same action in the Rev direction. The Forward Jog and Reverse Jog can be set independently.

The Forward and Reverse Jog inputs will have priority over other frequency references but the Reverse Jog input will not function if Reverse Operation is disabled (b1-04= "1: Reverse Disabled").

If both the Forward Jog and Reverse Jog are input simultaneously for 500 ms or more an external fault will occur and the Drive will stop, using the method set by b1-03.

Function: Fault Reset

Setting: 14

Whenever the Drive detects a fault condition, the fault output contact will close and the Drive's output will shut OFF causing the motor to coast (specific stopping methods can be selected for some faults such as L1-04 for motor overheat). Once the Run command is removed, the fault can be reset by either the RESET key on the digital operator or by closing a digital input configured as a Fault Reset (H1-0x= 14).

Function: Fast Stop N.O.

Setting: 15

The Fast Stop function operates much like an emergency stop input to the drive. While in the Run mode, if a Fast Stop is input to the Drive (CLOSED for H1-0x= 15 or OPEN for H1-0x= 17), the Drive will decelerate to a stop with the deceleration time determined by C1-09 (Fast Stop Time). The Run command can remain closed during the Fast Stop operation. The Drive will not run, from either the terminals or the digital operator, while the Fast Stop is being input to the Drive. To restart the Drive, the Fast Stop input must be removed and the Run command must be cycled.

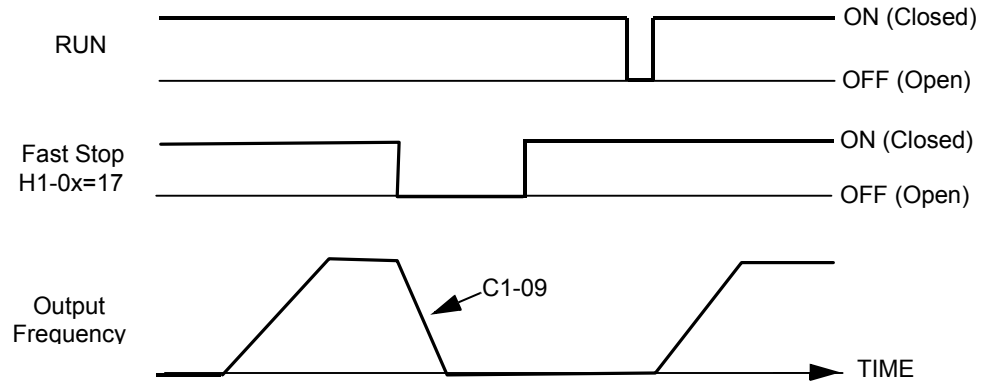

Fig. 49 Fast Stop Commands Time Chart

IMPORTANT

Be aware that during rapid deceleration the Drive may fault on an over voltage condition. When faulted, the Drive output shuts off allowing the motor to coast. The result is an uncontrolled motor state. Therefore, be sure to set an acceptable deceleration time in parameter C1-09 when using the fast stop feature.

Function: Motor 2 Selection

Setting: 16

The Drive has the capability to control 2 different motors independently. Motor 2 may be selected by closing the multi-function contact input programmed for motor 2 selection (H1-0x = 16). When motor 2 is selected E3 and E4 parameters set the V/f pattern, control method, and motor specifications.

Function: Fast Stop N.C.

Setting: 17

See setting 15 for details.

Function: Timer Function

Setting: 18

The Timer Function works independently from the Drive. For Timer operation a digital input must be configured for a Timer Function start (H1-0x= 18), a digital output must be configured as a Timer Function output (H2-0x= 12), and the Timer Function ON-Delay and OFF-Delay parameters (b4-01 and b4-02, respectively) must be programmed.

Once the applicable parameter are programmed the Timer Function start digital input must be closed at least as long as the setting of b4-01 before the Timer Function output will close. The Timer Function input must be open for at least as long as the setting of b4-02 before the Timer Function output will re-open.

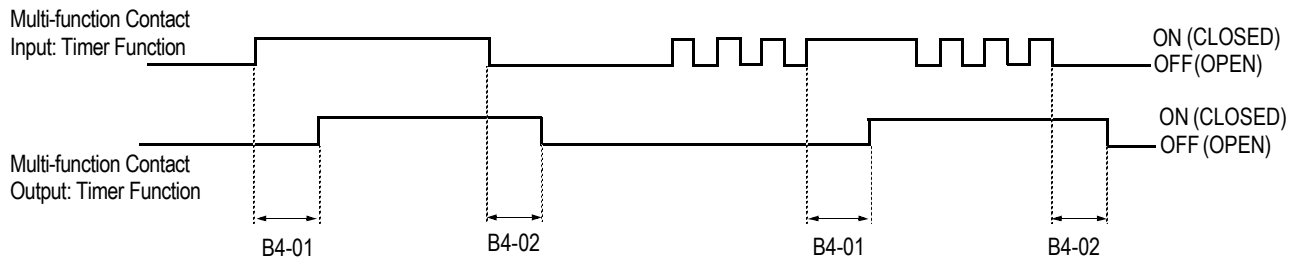

Fig. 50 Timer Function Time Chart

Function: PID Disable

Setting: 19

When the PID Function has been enabled by b5-01 (PID Mode Selection), it can be indefinitely disabled by closing a digital input configured as a PID Disable input (H1-0x= 19). When disabled, the Drive operates as a standard drive that does not have PID enabled

Function: Multi-Acceleration/Deceleration 2

Setting: 1A

See setting 7 for details.

Function: Program Lockout

Setting: 1B

A Program Lockout digital input will allow changing of parameter values when the input is closed but prevent changing of any Drive parameter value except the frequency reference when it is open. Parameter values can be viewed even when a Program Lockout is active.

Function: Trim Control Increase

Setting: 1C

Function: Trim Control Decrease

Setting: 1D

The Trim Control Increase and Trim Control Decrease must be used together and cannot be set independently. An OPE03 fault will occur if one is configured without the other. Once both are configured they can be used to trim the frequency reference by adding or subtracting a set frequency (d4-02) from the currently commanded speed. Once the input is cleared the frequency reference will return to the pre-Trim Control level. Refer to parameter d4-02.

The Trim Control Function is not effective when the frequency reference is coming from the digital operator.

Function: Reference Sample Hold

Setting: 1E

The Ref Sample Hold function will allow the user to sample an analog signal being input to A1, A2, or A3 and change the frequency reference to the sampled level. Once the digital input that is configured for the Ref Sample Hold function (H1-0x= 1E) is held for at least 100 ms, the Drive reads the analog input and changes the frequency reference to the newly sampled speed. If the digital input is not held for at least 100 ms, the analog input will not be sampled.

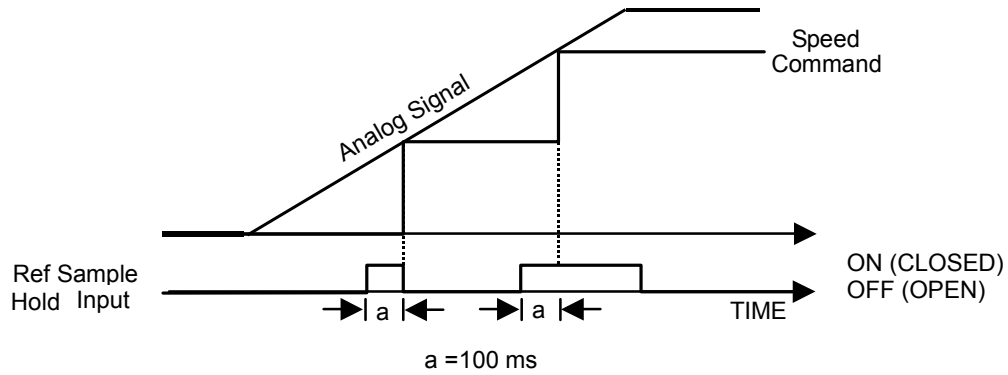

Fig. 51 Reference Sample Hold Time Chart

The Ref Sample Hold function cannot be programmed at the same time as the following digital input functions:

- Acc/Dec Ramp Hold
- MOP Increase/Decrease
- Trim Control Increase/Decrease

Doing so will cause an OPE03 fault to occur.

Cycling the input power will erase the sampled analog reference and the frequency reference will begin again from zero.

Function: External Fault

Setting: 20 through 2F

External Fault functionality can be programmed into the digital inputs of the Drive. The External Fault inputs can be used to signal to the Drive that other equipment related to the operation of the Drive has experienced problems. If the External Fault is input to the Drive the digital operator will display:

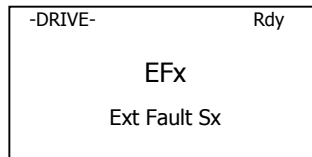

with the x in EFx and Sx represent the terminal number of the digital input that the fault was received on.

To program an External Fault the value input into the H1-0x parameter will determined by:

- Contact type wired to the terminal (Normally Open or Normally Closed)
- Detection profile (Always Detected or Only Detected while Running)
- Drive operation after fault (stopping Method or Continue Operation)

The following table shows the programming choices.

Table 16 Programming Choices								
Set Value	Input Contact Type		Detection Mode		stopping Method			
	N.O. contact	N.C. contact	Always Detected	Detected while Running	Decel to stop (major fault)	Coast to stop (major fault)	Fast stop (major fault)	Continue operation (minor fault)
20	X		X		X			
21		X	X		X			
22	X			X	X			
23		X		X	X			
24	X		X			X		
25		X	X			X		
26	X			X		X		
27		X		X		X		
28	X		X				X	
29		X	X				X	
2A	X			X			X	
2B		X		X			X	
2C	X		X					X
2D		X	X					X
2E	X			X				X
2F		X		X				X

Function: PID Integral Reset

Setting: 30

By configuring one of the digital inputs as an Integral Reset Input, (H1-0x= 30), the value of the integral component of PID control can be reset to zero whenever the configured input is CLOSED. The integral component of PID control will be held at zero as long as the configured digital input is held CLOSED.

Resetting the Integral component of PID control can be useful in cases where an excessively large Integral value prevents the PID control from responding quickly to changes in the system being regulated by the Drive (e.g. duct pressure, water temperature).

Function: PID Integral Hold

Setting: 31

By configuring a digital input as an Integral Hold input (H1-0X= 31), the value of the Integral component of the PID control can be forced to clamp at the value it was at when the input is CLOSED. The Integral component of the PID control returns to accumulating the error when the digital input is OPEN again.

Holding the Integral Value can be useful during periods when the error can build up naturally, such as during long accelerations. Not allowing Integral wind-up produces a more stable PID control.

Function: Multi-step Reference 4

Setting: 32

See setting 3, 4, and 5 for description.

Function: PID SFS Cancel

Setting: 34

SFS means softstart, also referred to as accel/decel in this description.

By configuring a digital input as a PID SFS (softstart) Cancel input (H1-0x= 34), the operator will be able to use a contact closure to remove the acceleration and deceleration times that are applied to changes in the PID setpoint by the b5-17 parameter. If the digital input configured as PID SFS Cancel is closed, the PID setpoint Accel/Decel (Parameter b5-17) will be ignored. Immediate updating of any change to the setpoint will apply.

Function: Input Level Selection

Setting: 35

When using the PID Function built into the Drive, the chosen set point is compared with the measured feedback. The difference is called the Error. The proportional and integral function are applied to this error. For some applications it may be appropriate to invert the input to the PID block. This can be accomplished by setting one of the digital inputs up as an Input Level Sel

(H1-0x=35). When an Input Level Sel digital input is closed the Error will be inverted before it is passed to the PID block.

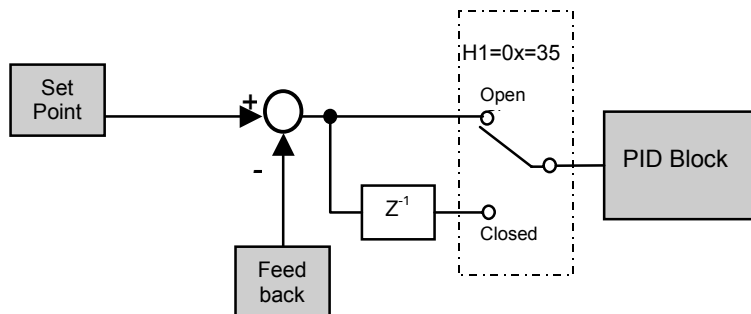

Fig. 52 PID Error signal Inversion Block Diagram

Function: DC Injection Braking

Setting: 60

When a DC injection braking command is input while the Drive is stopped, DC injection braking operation is activated. When a run command or a jog command is input, DC injection braking is released to start operation (jog operation has priority).

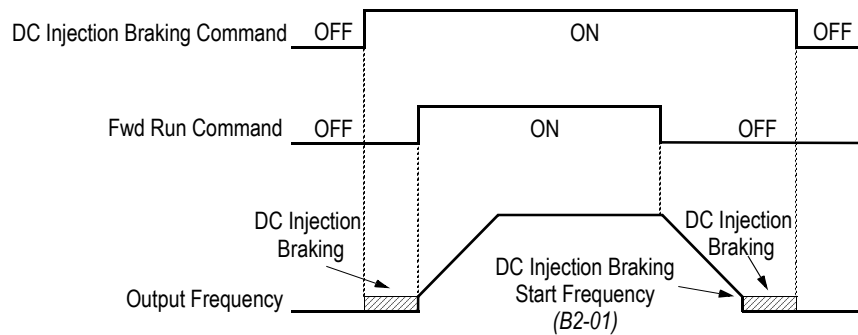

Fig. 53 DC Injection Braking Input Timing Diagram

Function: Speed Search 1

Setting: 61

Function: Speed Search 2

Setting: 62

Table 17 Digital Input Functions	
Setting of b3-01	Speed Search Method Used for Multi-function inputs
0	Speed Estimation
1	
2	Current Detection
3	

The Speed Search function can be turned on for all starts with parameter b3-01. If, however, it is beneficial to only use Speed Search at certain starts, a digital input can be programmed to turn on Speed Search only when it is closed.

Speed Search 1 will start searching for the rotor speed from the maximum frequency (E1-04). Speed Search 2 will begin searching for the rotor speed from the existing frequency reference. Speed Search 3 will cause the motor to baseblock when the switch is open and then perform Speed Search when it closes.

In all cases the form of Speed Search, Speed Estimation or Current Detection, is determined by the setting of b3-01. If b3-01= “0: SpdsrchF Disable”, then the Speed Estimation form of Speed Search is used. If b3-01= “2: SpdsrchI Disable”, then the Current Detection form of Speed Search is used.

Function: Field Weakening Command

Setting: 63

When the Field Weakening Command is closed (H1-0x = 63) the Drive’s output voltage level is reduced to the level set in parameter d6-01 at the output frequency set in d6-02. Field Weakening Command can only be in V/f control methods (A1-02 = 0 or 1).

Function: Speed Search 3

Setting: 64

See setting 61 and 62 for details.

Function: KEB Ridethru N.C.

Setting: 65

Function: KEB Ridethru N.O.

Setting: 66

The Kinetic Energy Braking (KEB) control circuit attempts to maintain the DC bus voltage at an optimum level [$1.35 \times$ input voltage (E1-01)] during momentary power loss, by using load inertia to regenerate voltage back to the DC bus. The Drive decelerates at the fast-stop rate (C1-09), until power is restored, or until the time runs out and an undervoltage fault (UV) occurs. The larger the inertia, the longer the deceleration rate can be extended. If the inertia is small, then the Drive must decelerate quickly to regenerate voltage back to the DC bus, and thus the ride-through time is shorter.

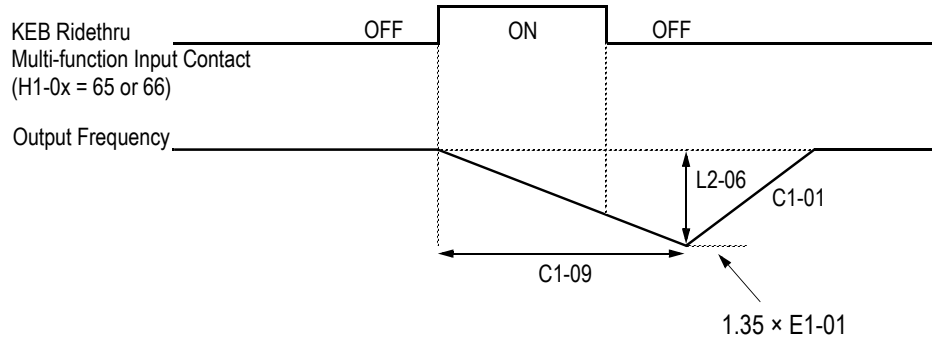

Fig. 54 KEB Ridethru Timing Diagram

Note: Larger model inverters (F7U2022 and above, F7U4018 and above) require a separate uninterruptible power supply (UPS) for control power, in order for load inertia ridethru to be effective.

Function: Communication Test Mode
Setting: 67

The Drive has a built-in function for self-diagnosing the serial communications operation. The test involves wiring the send and receive terminals of the RS-485/422 port together. The Drive transmits data and then confirms the communications are received normally.

In order to perform the serial communications self-diagnosis, terminal S7 must be programmed as the Comm Test Mode digital input (H1-05= "67: Com Test Mode") and then power removed from the Drive and the following steps performed:

1. Wire the S7 and SC terminals of the control circuit terminals together

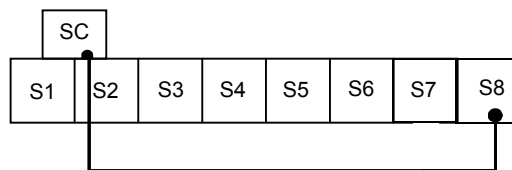

2. Wire the R+ and S+ terminals of the RS-485/422 port together
3. Wire the R- and S- terminals of the RS-485/422 port together

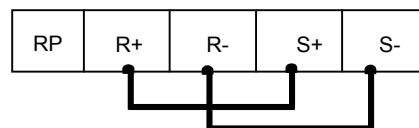

4. Turn On the terminating resistance (Move Switch 1 of Dip Switch 1 to the ON position).

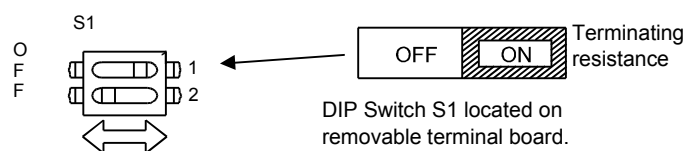

Fig. 55 DIP Switch Setting for Terminating Resistor
 Programming 84

5. Turn on power to the Drive.

After step 5 above the Drive will either display “Pass” if everything is okay or a CE alarm will be displayed. If the CE alarm occurs, the fault output contact will energize.

Function: High Slip Braking

Setting: 68

A digital input can be configured as a High Slip Braking (HSB) command (H1-0x= 68). The HSB feature is intended to be used in applications where the load is high inertia and actual stopping time is not critical. The HSB feature does not “brake” the motor at a predetermined rate, but rather, creates a braking effect based on applied voltage and frequency to the motor. The result is reduced deceleration time as compared to a coasting load, yet the actual deceleration time is unknown (trial and error basis). The HSB feature does not require braking resistors. When the High Slip Braking input is closed during Run mode, the Drive will begin the High Slip Braking function. A braking time can be achieved that is approximately 50% of the time required to decelerate the load normally even without using braking resistors. The High Slip Braking function cannot be exited until the Drive is completely stopped.

The High Slip Braking function manipulates the output frequency while monitoring the output current and DC Bus to create a large slip condition. The regenerative energy caused by the shortened stopping is changed to heat by the motor windings. The increased motor heating limits the HSB duty cycle to 5% and stopping time should be limited to 90 seconds or less.

Function: Jog 2

Setting: 69

The Jog2 function applies to 3-Wire control only. If a digital input is configured as Jog2 (H1-0x= 69) when the drive is not in 3-Wire Control, an OPE03 fault will occur.

The Jog2 input will cause the Drive to ramp to the Jog Frequency Reference (d1-17) in the direction dictated by the Fwd/Rev input of the 3-Wire Control mode. Accelerating to and from the Jog Frequency Reference will be determined by the active Accel/Decel parameters.

Function: Drive Enable

Setting: 6A

A digital input configured as a Drive Enable input (H1-0x= 6A) will prevent the Drive from executing a Run command until it is closed. When the Drive Enable input is open the digital operator will display:

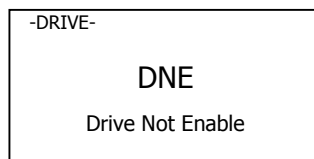

If a Run command is closed prior to the Drive Enable input being closed the Drive will not run until the Run command is cycled.

If the Drive Enable input is opened while the Drive is running, the Drive will stop, using the method set by parameter b1-03.

Function: Speed / Torque Control Selection

Setting: 71

This multi-function digital input is used to switch the Drive between speed control and torque control. The function is only available in flux vector control method (A2-01 = 3). Parameter D5-01 must be set to 0 and an analog input terminal (A2 or A3) must be programmed for function “13: torque reference”.

When the programmed terminal is open (off), the Drive will operate in speed control. The speed reference source is determined by parameter b1-01. The torque limit used is the smaller of the analog input limit (if an analog input is programmed for function 10, 11, 12, or 15), the torque limit parameter value (L7 group), or the absolute value of the analog input programmed for function “13: torque reference”, which acts as a 4-quadrant torque limit. There are multiple torque limits for each quadrant. If the run command is removed during speed control, the Drive will stay in speed control and stop according to parameter b1-03. For ramp to stop, the Drive will use the active torque limit as described above.

When the programmed terminal is closed (on), the Drive will operate in torque control. The torque reference will come from the analog input terminal (A2 or A3) programmed for function “13: torque reference”. The speed limit is determined by parameter d5-03. If d5-03 = 1, the speed limit used is the output of the soft starter as determined by b1-01, the analog input settings for A2 or A3, the active accel/decel time, and the s-curve settings. If d5-03 = 2, the speed limit is determined by parameter d5-04. If a stop command is received during torque control, the Drive will automatically switch to speed control and stop according to parameter b1-03. For ramp to stop, the Drive will use the active torque limit as described above.

Function: Zero Servo Command

Setting: 72

Zero-servo function provides position control capability at zero speed. When zero-servo is enabled by closing the programmed multi-function input, and the output frequency is less than the DC injection start frequency (b2-01), the shaft position is maintained by monitoring PG feedback pulses and correcting the position error. However, this function does not have the same capabilities of a position controller because there is no marker pulse feedback. Therefore, the motor will not stop in the same position every time the zero servo command is enabled.

Function: ASR Gain Switch

Setting: 77

This multi-function digital input is used to switch between ASR Gain 1 (C5-01) and ASR Gain 2 (C5-03). The function is only available in Flux Vector control method (A1-02 = 3). The ASR gain switch function has priority over the ASR switchover frequency parameter (C5-07). It will ramp from one gain to the other using the active ASR integral time. The use of the ASR gain switch allows for two different machine/motor responsiveness set-ups. This can be used for breaking loose a high friction load at start, acceleration versus constant speed, two different products running on the same machine, etc.

Function: Polarity Reversing Command

Setting: 78

This multi-function digital input is used to switch the polarity of the analog torque reference command (multi-function analog input function “13: Torque Reference / Limit”). The function is only available in Flux Vector control method (A1-02 = 3). The Drive must be in torque control by either setting D5-01 = 1 or setting D5-01 = 0 and closing the multi-function digital input function “71: Speed / Torque Changeover”. This function does not affect the signal when the Speed / Torque Changeover input is open (speed mode with the analog signal acting as a torque limit). This function is valid for either analog input terminal (A2 or A3) and any input signal level (4 to 20 mA, 0 to 10V, +/- 10V). When in torque control, the direction of the motor rotation is determined solely by the polarity of the torque reference command. This function provides for easy switching of the motor direction.

◆ H2 Digital Outputs

- H2-01 Terminal M1-M2 Function Selection
- H2-02 Terminal M3-M4 Function Selection
- H2-03 Terminal M5-M6 Function Selection

Setting Range: 0 to 38

Factory Default: H2-01 = “0: During Run 1”

H2-02 = “1: Zero Speed”

H2-03 = “2: Fref/Set Agree 1”

The Drive has two multi-function outputs. By programming parameters H2-01 and H2-02, the user can assign specific functions to each output. Below is a table with a complete list of all of the digital output functions. Following the table is a more detailed description of each of the functions.

Parameter Setting	Function	Control Method (A1-02)			
		V/f	V/f with PG	Open Loop Vector	Flux Vector
0	During Run 1 (<i>factory default, H2-01</i>)	0	0	0	0
1	Zero Speed (<i>factory default, H2-02</i>)	0	0	0	0
2	Fref/Fout Agree 1 (<i>factory default, H2-03</i>)	0	0	0	0
3	Fref/Set Agree 1	0	0	0	0
4	Frequency Detection 1	0	0	0	0
5	Frequency Detection 2	0	0	0	0
6	Inverter Ready	0	0	0	0
7	DC Bus Undervoltage	0	0	0	0
8	Base Block 1 N.O.	0	0	0	0
9	Operator Reference	0	0	0	0
A	Local/Remote Operation	0	0	0	0
B	Torque Detection 1 N.O.	0	0	0	0
C	Loss of Reference	0	0	0	0
D	Braking Resistor Fault	0	0	0	0
E	Fault	0	0	0	0
F	Not Used	0	0	0	0
10	Alarm	0	0	0	0
11	Reset Command Active	0	0	0	0
12	Timer Output	0	0	0	0
13	Fref/Fout Agree 2	0	0	0	0
14	Fref/Set Agree 2	0	0	0	0
15	Frequency Detection 3	0	0	0	0
16	Frequency Detection 4	0	0	0	0
17	Torque Detection 1 N.C.	0	0	0	0
18	Torque Detection 2 N.O.	0	0	0	0
19	Torque Detection 2 N.C.	0	0	0	0
1A	Reverse Direction	0	0	0	0
1B	Baseblock 2 N.C.	0	0	0	0
1C	Motor 2 Selection	0	0	0	0

Table 18 Digital Output Functions (Continued)						
Parameter Setting	Function	Control Method (A1-02)				
		V/f	V/f with PG	Open Loop Vector	Flux Vector	
1D	Regenerating	X	X	X	O	
1E	Restart Enabled	O	O	O	O	
1F	Overload (OL1)	O	O	O	O	
20	OH Alarm	O	O	O	O	
30	During Torque Limit (when in speed control)	X	X	O	O	
31	During Speed Limit	X	X	X	O	
32	During Speed Limit (when in torque control)	X	X	X	O	
33	Zero Servo Complete	X	X	X	O	
37	During Run 2	O	O	O	O	
38	Drive Enable	O	O	O	O	

Function: During Run 1

Setting: 0

A During Run 1 output will close whenever the Run command is provided and the Drive is outputting voltage. This includes deceleration and DC Injection.

Function: Zero Speed

Setting: 1

The “Zero Speed” output will close whenever the output frequency falls below the Minimum Frequency (E1-09).

Function: Fref/Fout Agree 1

Setting: 2

The “Fref/Fout Agree 1” output will close whenever the actual output frequency is within the Speed Agree Width (L4-02) of the current frequency reference regardless of the direction.

Function: Fref/Set Agree 1

Setting: 3

The “Fref/Set Agree 1” output will close whenever the actual output frequency and the frequency reference are within the Speed Agree Width (L4-02) of the programmed Speed Agree Level (L4-01).

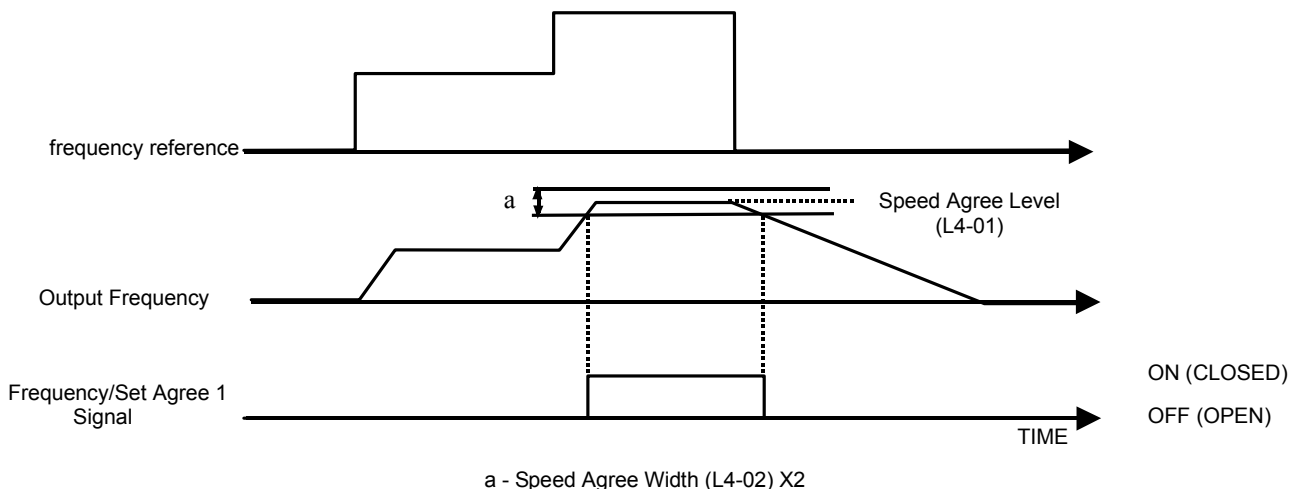

a - Speed Agree Width (L4-02) X2
 Fig. 56 Fref/Set Agree 1 Timing Diagram
 Programming 88

Function: Frequency Detect 1

Setting: 4

A “Freq Detect 1” output will be closed whenever the output frequency is equal to or below the value of the programmed Speed Agree Level (L4-01). The Speed Agree Width (L4-02) is the hysteresis to the Freq Detect 1 function. Whenever the output frequency approaches the Speed Agree Level while accelerating it will need to be equal to or exceed the Speed Agree Level (L4-01) plus the Speed Agree Width (L4-02) before the Freq Detect 1 output will energize.

As the output frequency approaches the Speed Agree Level while decelerating, the Freq Detect 1 output will de-energize exactly at the Speed Agree Level.

The Freq Detect 1 function is effective during both forward and reverse operation.

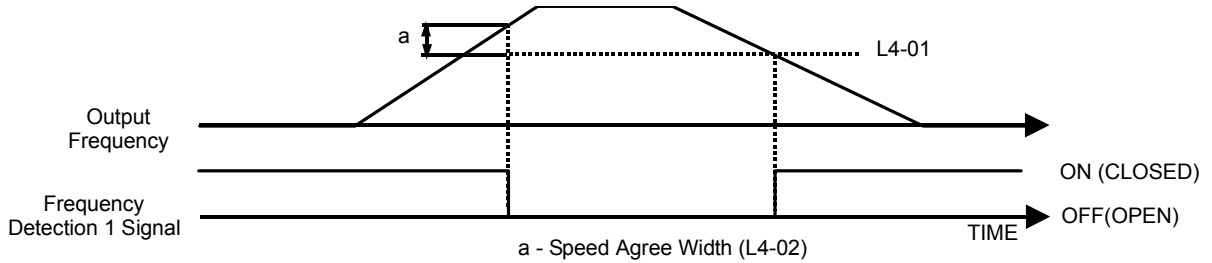

Fig. 57 Freq Detect 1 Timing Diagram

Function: Frequency Detect 2

Setting: 5

A Freq Detect 2 output will be closed whenever the output frequency is equal to or above the value of the programmed Speed Agree Level (L4-01). The Speed Agree Width (L4-02) is the hysteresis to the Freq Detect 2 function. Whenever the output frequency approaches the Speed Agree Level (L4-01) while accelerating it will de-energize exactly at the Speed Agree Level.

As the output frequency approaches the Speed Agree Level while decelerating, the Freq Detect 2 output will de-energize when the output frequency is equal to or below the Speed Agree Level (L4-01) minus the Speed Agree Width (L4-02).

The Freq Detect 2 function is effective during both forward and reverse operation.

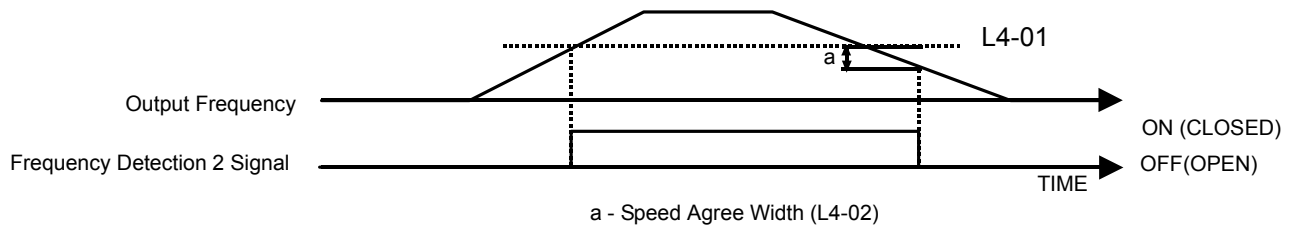

Fig. 58 Freq Detect 2 Timing Diagram

Function: Inverter Ready

Setting: 6

The Inverter Ready output will be closed whenever the Drive is not in a fault state and not being programmed. If b1-08 = “1: Enabled”, a Drive that is in an active Run state that is also being programmed will have the Inverter Ready output closed.

Function: DC Bus Undervoltage

Setting: 7

The DC Bus Undervoltage output will close whenever the main circuit DC Bus voltage or control circuit power supply drop below their respective trip level. The undervoltage trip level is determined by parameter L2-05. An open soft charge contactor answer back signal will also cause the DC Bus Undervoltage output to close.

Function: Base Block 1 N.O.

Setting: 8

A BaseBlk 1 programmed output will close to indicate that the Drive is in baseblocked state. While in a baseblock state the Drive’s output transistors are prevented from firing. A BaseBlk 1 output contact can also serve as notice that the Drive has a charged DC Bus, no fault and can start at any time.

Function: Operator Reference

Setting: 9

When an output is configured as an Operator Reference output, the output will close to show that the frequency reference is being sourced from the digital operator. If the Operator Reference output is open, it indicates the frequency reference is coming from the control circuit terminals or an optional communications card.

Function: Local/Remote Operation

Setting: A

When an output is configured as a Local/Remote Operation output, the output will close to show that the Run command is being sourced from the digital operator. If the Local/Remote Operation output is open, it indicates the Run command is coming from the control circuit terminals or an optional communications board.

Function: Torque Detection 1 N.O.

Setting: B

The Torque Detection 1 function ties a digital output to the overtorque/undertorque sensing capabilities of the Drive. If a digital output is configured as Torque Detection 1 N.O., whenever the output current differs from the level of L6-02 for at least the length of time set in L6-03, the digital output will close.

The torque detection function has a built-in hysteresis of 10% of the Drive rated output current.

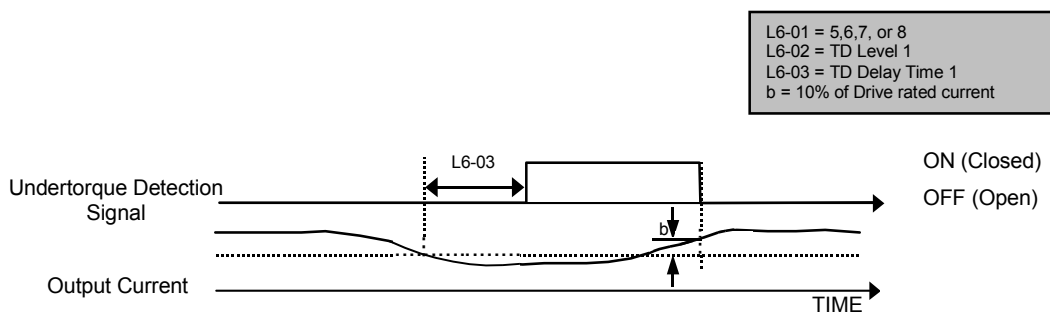

Fig. 59 Torque Detection 1 N.O. Timing Diagram

Function: Loss of Reference

Setting: C

The Loss of Reference configured digital output will close when the Drive has detected a loss of the analog frequency refer-

ence. The frequency reference is considered lost when the voltage level drops 90% in 0.4 seconds. Parameter L4-05 determines the Drive's reaction to a loss of reference state in addition to turning on the Loss of Reference digital output.

The Loss of Reference digital output will only initiate if the Drive is configured for the frequency reference to be via one of the analog inputs (A1, A2, or A3).

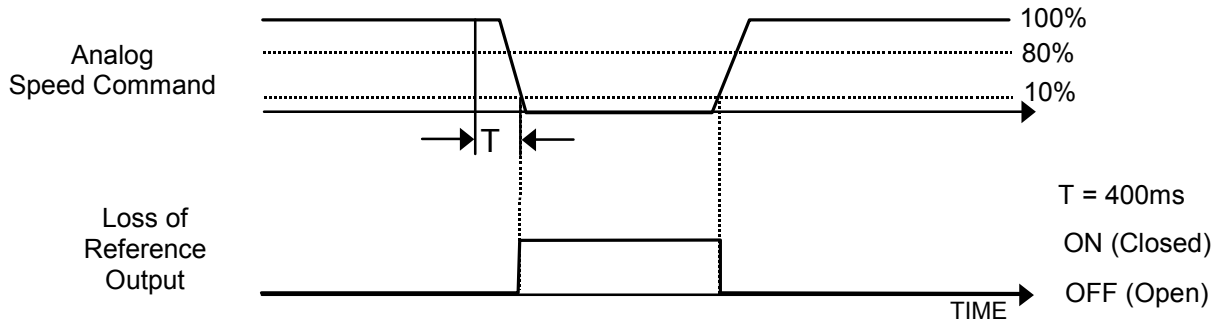

Fig. 60 Loss of Reference Function Characteristics

Function: DB Overheat

Setting: D

When the dynamic braking resistor (DB) overheats or the braking transistor is in a fault condition, the DB Overheat configured digital output will close.

Function: Fault

Setting: E

The Fault configured digital output will close whenever the Drive experiences a major fault with the exception of the CPF00 and CPF01 (Digital Operator Communications Faults).

Function: Not Used

Setting: F

The Not Used setting can be used to disable the digital output.

Function: Minor Fault

Setting: 10

A Minor Fault, also referred to as an alarm, indicates that a condition exists that may be critical to the Drive or application but does not require the Drive to stop. A minor fault will be flashed on the digital operator but neither the Fault output (MA-MB) nor any digital output configured as a Fault output (H2-0x= E) will close. Any digital output configured as Minor Fault will close whenever a minor fault of alarm condition exists.

Function: Reset Command Active

Setting: 11

A Reset Command Active digital output will close to signal that a fault reset is being attempted from terminals, serial communication, or communication option board.

Function: Timer Output**Setting: 12**

This Timer function, that is built into the Drive, is independent of the rest of the Drive operation, i.e. there is no requirement for a Run command for the timer to operate. A Timer digital output will close b4-01 seconds after a digital input configured as Timer Input (H1-0x= 18) closes and remains closed. The Timer digital output will remain closed for b4-02 seconds after the Timer digital input opens and remains open.

Refer to the descriptions of parameters b4-01 and b4-02 for a timing chart of the Timer function.

Function: Fref/Fout Agree 2**Setting: 13**

The “Fref/Fout Agree 2” output will close whenever the actual output frequency is within the Speed Agree Width (L4-04) of the current frequency reference regardless of the direction.

Function: Fref/Fset Agree 2**Setting: 14**

The “Fref/Set Agree 2” output will close whenever the actual output frequency and the frequency reference are within the Speed Agree Width (L4-04) of the programmed Speed Agree Level (L4-03). This Fref/Fset Agree 2 output is direction sensitive according to the direction programmed in L4-03.

Function: Freq Detect 3**Setting: 15**

A “Freq Detect 3” output will be closed whenever the output frequency is equal to or below the value of the programmed Speed Agree Level (L4-03). The Speed Agree Width (L4-04) is the hysteresis to the Freq Detect 3 function. Whenever the output frequency approaches the Speed Agree Level while accelerating it will need to be equal to or exceed the Speed Agree Level (L4-03) plus the Speed Agree Width (L4-04) before the Freq Detect 3 output will energize.

As the output frequency approaches the Speed Agree Level while decelerating, the Freq Detect 3 output will de-energize exactly at the Speed Agree Level.

This Freq Detect 3 output is direction sensitive according to the direction programmed in L4-03.

Function: Frequency Detection 4**Setting: 16**

A Frequency Detect 4 output will be closed whenever the output frequency is equal to or above the value of the programmed Speed Agree Level (L4-03). The Speed Agree Width (L4-04) is the hysteresis to the Freq Detect 4 function. Whenever the output frequency approaches the Speed Agree Level (L4-03) while accelerating it will de-energize exactly at the Speed Agree Level.

As the output frequency approaches the Speed Agree Level while decelerating, the Freq Detect 4 output will de-energize when the output frequency is equal to or below the Speed Agree Level (L4-03) minus the Speed Agree Width (L4-04).

This Freq Detect 3 output is direction sensitive according to the direction programmed in L4-03.

Function: Torque Detection 1 N.C.

Setting: 17

The Torque Detection 1 function ties a digital output to the overtorque/undertorque sensing capabilities of the Drive. If a digital output is configured as Torque Detection 1 N.C., whenever the output current exceeds the level of L6-02 for at least the length of time set in L6-03, the digital output will open.

The torque detection function has a built-in hysteresis of 10% of the Drive rated output current.

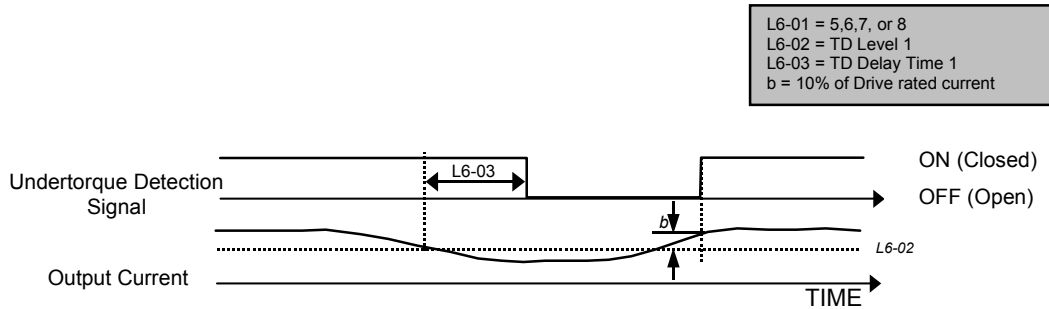

Fig. 61 Torque Detection 1 N.C. Timing Diagram

Function: Torque Detection 2 N.O.

Setting: 18

Function: Torque Detection 2 N.C.

Setting: 19

The Torque Detection 2 N.O. and Torque Detection 2 N.C. functions tie the digital output to the overtorque/undertorque sensing capabilities of the Drive. If a digital output is configured as Torque Detection 2 N.O. or Torque Detection 2 N.C., whenever the output current exceeds the level of L6-05 for at least the length of time set in L6-06, the digital output will close or open, respectively.

Function: Reverse Direction

Setting: 1A

The Reverse Direction digital output will close whenever the Drive is turning the motor in the direction that corresponds to the reverse direction (CW or CCW). The Reverse Direction digital output will remain closed during deceleration when the rotation is in the reverse direction.

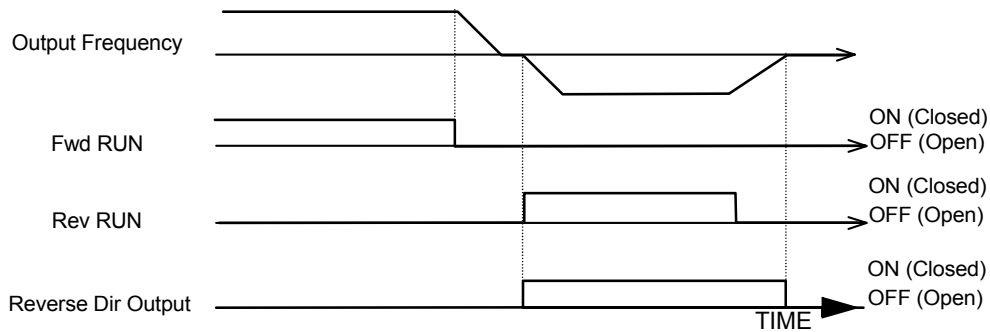

Fig. 62 Reverse Direction Timing Diagram

Function: BaseBlock 2 N.C.**Setting: 1B**

A BaseBlock 2 N.C. programmed output will open to indicate that the Drive is in baseblocked state. While in a baseblock state the Drive's output transistors are prevented from firing. A BaseBlk 2 output contact can also serve as notice that the Drive has a charged DC Bus, no fault and can start at any time.

Function: Motor 2 Selected**Setting: 1C**

A Motor 2 Selected programmed output will close when multi-function input programmed for motor 2 selection (H1-0x = 16) is closed.

Function: Regenerating**Setting: 1D**

A Regenerating programmed output will close during regenerative operation. Regenerative operation is when the slip of the motor is in the negative direction of normal motoring operation, i.e. deceleration. This function can only be used in flux vector control (A1-02 = 3)

Function: Restart Enabled**Setting: 1E**

Depending on the setting of parameter L5-01, the Drive may be configured to automatically attempt to restart itself after certain faults. The Restart Enabled output will be closed once the restarts begin and will remain closed until a successful restart is accomplished or the number of Auto Restart attempts as specified by L5-01 is reached.

A timing diagram for the Auto Restart function is contained in the parameter L5-01 description.

Function: Overload (OL1) Alarm**Setting: 1F**

The OL1 fault function is designed to protect the motor. It estimates the motor's winding temperature based on the output current, output frequency, and time. The OL1 time is determined by the setting of parameters E2-01 (or E4-01), L1-01, and L1-02. An Overload digital output will close whenever 90% of the programmed OL1 time is exceeded.

Function: OH Prealarm**Setting: 20**

The Overheat fault function (OH) is designed to protect the Drive from excessive temperature damage. Thermistors attached to the heatsink of the Drive monitor the temperature near the devices attached to the heatsink (e.g. input diode modules, output transistor modules) and will fault the drive if the temperature reaches 105°C.

An OH Prealarm digital output will close whenever the heatsink temperature reaches the level specified by parameter L8-02. Parameter L8-03 will determine the Drive's response to reaching the OH Prealarm level, in addition to closing the configured digital output.

Function: During Torque Limit**Setting: 30**

When the Drive's torque reference reaches the torque limit set in L7-01 to L7-04, the output programmed for During Torque Limit is closed. This setting is only valid when in open loop vector or flux vector control method (A1-02 = 2 or 3).

Function: During Speed Limit**Setting: 31**

The Speed Limit output closes when the speed limit level set according to parameter d5-03 (speed limit level set by either parameter d5-04 or analog input A1, A2, or A3) is reached. This setting is only valid when running in speed control mode (d5-01 = 0) and in flux vector control method (A1-02 = 3).

Function: During Speed Limit (when in torque control)**Setting: 32**

The Speed Limit output closes when the speed limit level set according to parameter d5-03 (speed limit level set by either parameter d5-04 or analog input A1, A2, or A3) is reached. This setting is only valid when running in torque control mode (d5-01 = 1) and in flux vector control method (A1-02 = 3).

Function: Zero-Servo Complete**Setting: 33**

The Zero-Servo Complete output closes when zero-servo function is completed. The zero-servo function is activated by closing the multi-function input programmed for zero-servo command (H1-0x = 72).

Function: During Run 2**Setting: 37**

A During Run 2 output will close whenever the Run command is provided and the Drive is outputting voltage. This does not include baseblock, DC Injection, and initial excitation.

Function: Drive Enabled**Setting: 38**

A Drive Enable digital output will reflect the status of a digital input configured as a Drive Enable input (H1-0x= 6A). If the Drive Enable digital input is closed then the Drive Enabled digital output will also close.

◆ H3 Analog Inputs

■ H3-01 Terminal A1 Signal Level Selection

Setting	Description
0	0 to 10 Vdc
1	-10 to +10 Vdc (<i>factory default</i>)

The H3-01 parameter (Terminal A1 Signal Level) allows the programmer to specify the signal that will be applied to the A1 analog input. The A1 analog input can accept either a 0 to 10 Vdc or -10 to +10 Vdc signal as a reference.

■ H3-02 Terminal A1 Gain Setting

Setting Range: 0.0 to 1000.0%

Factory Default: 100.0%

■ H3-03 Terminal A1 Bias Setting

Setting Range: -100.0% to +100.0%

Factory Default: 0.0%

In order to have the Drive properly interpret an analog input, it may be necessary to apply a gain and/or a bias to the signal. The analog inputs have a resolution of 10 bits (1024 steps). Using the factory default settings for the analog input's gain and bias, the 0 to 10Vdc or -10 to +10 Vdc signal at the analog input will yield a 0-100% frequency reference span.

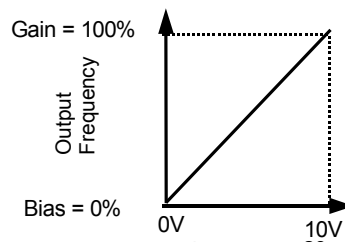

Fig. 63 Output Frequency as Commanded Via Analog Input

If a different span of analog input signal is desirable, it will be necessary to adjust the gain, the bias, or both to allow the analog input level to generate the desired frequency command. Adjustment of the gain setting will change the frequency reference that is equivalent to the maximum analog input (10 Vdc). If, for instance, the gain is increased to 200%, then 10Vdc will be equivalent to a 200% frequency reference and 5 Vdc will be equivalent to a 100% frequency reference. Since the Drive output is limited by the maximum frequency parameter (E1-04), 0-5Vdc will now be equivalent to 0-100% frequency reference span.

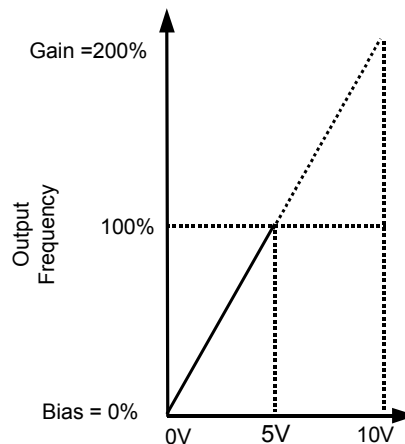

Fig. 64 Output Frequency as Commanded via Analog Input with Increased Gain Setting

Adjustment of the bias setting will likewise adjust the frequency reference that is equivalent to the minimum analog input level (0Vdc). If, for instance, the bias is set to -25%, then 0Vdc will be equivalent to a -25% frequency reference. Since the minimum frequency reference is 0% an analog input of 2.5 to 10Vdc will now be equivalent to 0-100% speed command span.

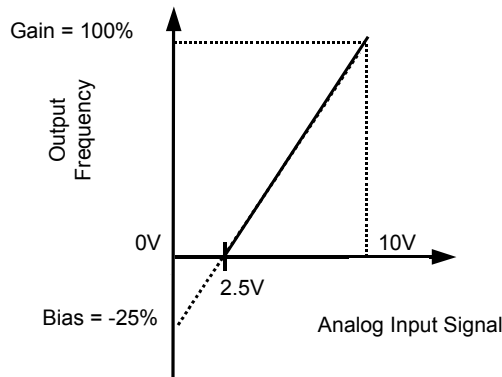

Fig. 65 Output Frequency with Reduced Bias Setting

As a further example, for an inverse-acting frequency reference, set the bias= 100% and the gain= 0%. The minimum analog input level (0Vdc) will produce a 100% frequency reference and the maximum analog input level (10Vdc) will produce a 0% frequency reference.

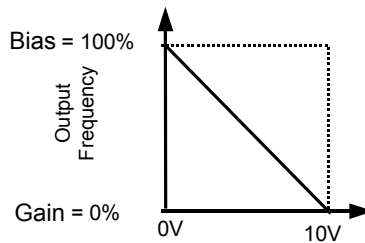

Fig. 66 Output Frequency with Inverted Gain and Bias Settings

■ H3-04 Terminal A3 Signal Level Selection

Setting	Description
0	0 to 10 Vdc
1	-10 to +10 Vdc (<i>factory default</i>)

The H3-04 parameter (Terminal A3 Signal Level) allows the programmer to specify the signal that will be applied to the A3 analog input. The A3 analog input can accept either a 0 to 10 Vdc or -10 to +10 Vdc signal as a reference.

■ H3-05 Terminal A3 Function Selection

Setting Range: 0 to 1F

Factory Default: 2: Auxiliary Frequency Reference 1

Parameter H3-05 performs the same function for the A3 analog input that parameter H3-09 performs for A2 analog input. Please refer to the parameter description for H3-09 for details. The level of the A3 analog input, as a percentage of the maximum input, can be viewed by the U1-17 monitor.

■ H3-06 Terminal A3 Gain Setting

Setting Range: 0.0 to 1000.0%

Factory Default: 100.0%

■ H3-07 Terminal A3 Bias Setting

Setting Range: -100.0% to +100.0%

Factory Default: 0.0%

Parameters H3-06 and H3-07 perform the same function for the A3 analog input that parameters H3-02 and H3-03 perform for the A1 analog input. Please refer to the parameter description for H3-02 and H3-03 for details.

■ H3-08 Terminal A2 Signal Level

Setting	Description
0	0 to 10VDC
1	-10 to 10VDC
2	4 to 20mA (<i>factory default</i>)

The H3-08 parameter (Terminal A2 Signal Level) allows the programmer to specify the signal that will be applied to the A2 analog input. The A2 analog input can accept either a 0 to 10 Vdc, -10 to +10 Vdc, or 4-20 mA signal as a reference. The Drive also has a dipswitch (S1) on the removable terminal board that must be set for the proper reference signal into the A2 analog input. The S1-2 dipswitch setting determines the internal resistance of the A2 input but parameter H3-08 determines how the Drive interprets the measured signal.

DIP Switch S1 and Jumper CN15

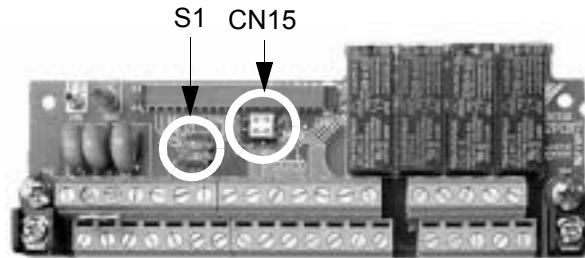

Fig. 67 DIP Switch S1 and Jumper CN15 Location

DIP Switch S1 is described in this section. The functions of DIP switch S1 are shown in Table 19.

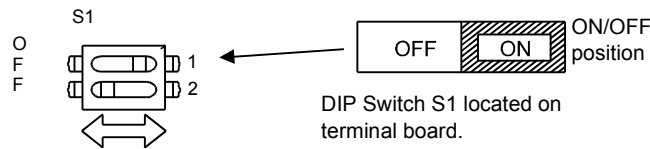
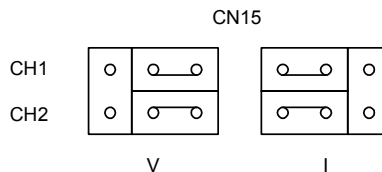

Fig. 67a DIP Switch S1 Function

Name	Function	Setting
S1-1	RS-485 and RS-422 terminating resistance	OFF: No terminating resistance ON: Terminating resistance of 110 Ω Factory Default = OFF
S1-2	Input method for analog input A2	OFF: 0 to 10Vdc or -10 to 10Vdc (internal resistance: 20KΩ) ON: 4-20mA (internal resistance: 250 Ω) Factory Default = ON

Jumper CN15 is described in this section. The jumper position of CH1 and CH2 determines the signal level of the multi-function analog output FM and AM, respectively. The functions and positions of CN15 are shown in Table 19a.



Name	Multi-function Analog Output	Output Range
CH1	FM	V: 0 to 10V or -10V to +10V (default) I: 4 to 20mA
CH2	AM	V: 0 to 10V or -10V to +10V (default) I: 4 to 20mA

■ H3-09 Terminal A2 Function Selection

Table 20 Analog Input Functions					
Parameter Setting	Function	Control Method (A1-02)			
		V/f	V/f with PG	Open Loop Vector	Flux Vector
0	Adds to Terminal A1 (<i>factory default, H3-09</i>)	0	0	0	0
1	Frequency Reference Gain	0	0	0	0
2	Aux. Frequency Reference 1 (<i>factory default, H3-05</i>)	0	0	0	0
3	Aux. Frequency Reference 2	0	0	0	0
4	Output Voltage Bias	0	0	X	X
5	Accel / Decel Time Coefficient	0	0	0	0
6	DC Injection Braking Current	0	0	0	X
7	Overtorque / Undertorque Detection Level	0	0	0	0
8	Stall Prevention Level During Run	0	0	X	X
9	Frequency Reference Lower Limit	0	0	0	0
A	Jump Frequency 4	0	0	0	0
B	PID Feedback	0	0	0	0
C	PID Set Point	0	0	0	0
D	Frequency Reference Bias 2	0	0	0	0
E	Motor Temperature	0	0	0	0
10	FWD Torque Limit	X	X	0	0
11	REV Torque Limit	X	X	0	0
12	Regenerative Torque Limit	X	X	0	0
13	Torque Reference	X	X	X	0
14	Torque Compensation	X	X	X	0
15	FWD/ REV Torque Limit	X	X	0	0
1F	Not Used	0	0	0	0

The A2 or A3 analog input can be programmed to perform many different functions. The setting of parameter H3-09 and H3-05 determines which of the following functions the A2 or A3 analog input will respectively perform. The level of the A2 analog input, as a percentage of the maximum input, can be viewed by the U1-16 monitor.

Function: Adds to Terminal A1

Setting: 0

By setting analog input to 0 the level of the analog input will be summed with the level of the frequency reference analog input A1.

Function: Frequency Gain

Setting: 1

Setting analog input to 1 allows the analog input to act as a gain to the frequency reference.

1: Frequency Reference Gain

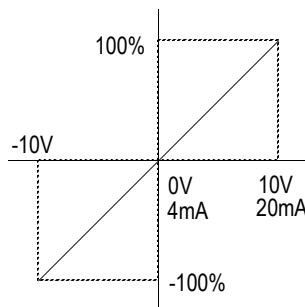

Fig. 68 Frequency Reference Gain

Function: Aux Reference 1

Setting: 2

Function: Aux Reference 2

Setting: 3

Aux reference 1 and aux reference 2 works in conjunction with preset reference 2 and 3. In order for the analog input A2 or A3 to be used as the master frequency reference, the analog input must be set for Aux Reference 1 or Aux Reference 2 and the digital input programmed for Multi-Step Ref 1 (H1-0x= 3) or Multi-Step Ref 1 (H1-0x= 3), respectively, must be selected by a contact closure. See parameter d1-xx for details.

Function: Voltage Bias

Setting: 4

Voltage bias boosts the output voltage of the V/f curve as a percentage of motor rated voltage (E1-05).

Function: Acceleration / Deceleration Change

Setting: 5

Acc / Dec change functions as a gain for the active acceleration and deceleration time (C1-01 to C1-08).

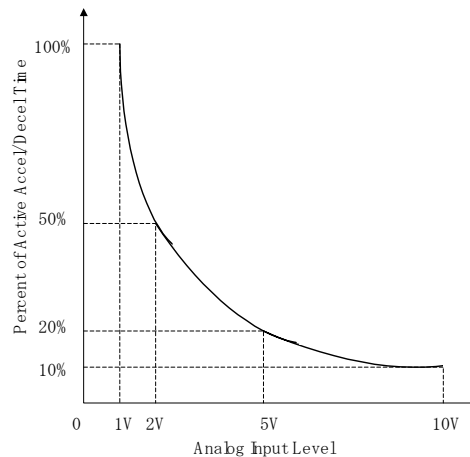

Fig. 69 Accel / Dece; Time Change

Function: DC Brake Current

Setting: 6

DC brake current allows the analog input level to set the DC injection braking current level as a percentage of Drive rated current.

Function: Overtorque Level

Setting: 7

Overtorque level sets the overtorque/undertorque detection level using the analog input. This works with torque detection selection 1 (L6-01) and will take the place of the torque detection level 1 (L6-02). For open loop vector and flux vector control methods (A1-02 = 2 or 3) 100% = motor rated torque. For V/f without PG and V/f with PG (A1-02 = 0 or 1) 100% = Drive rated current.

Function: Stall Prevention Level

Setting: 8

Stall prevention level allows the analog input to change the stall prevention level during run (L3-06) as a percentage of the set value. Either the analog input stall prevention level or L3-06 setting, whichever is lower, becomes effective.

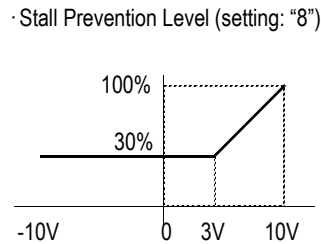

Fig. 70 Stall Prevention Level

Function: Reference Lower Limit

Setting: 9

Reference lower limit allows the analog input to adjust the frequency lower limit level as a percentage of maximum output frequency (E1-04). This works in conjunction with frequency reference lower limit d2-02. Either the analog input reference lower limit level or d2-02 setting, whichever is greater, becomes effective.

Function: Jump Frequency

Setting: A

Jump Frequency allows the analog input to set a fourth jump frequency level in addition to jump frequency 1, 2, and 3 (d3-01, d3-02, and d3-03, respectively) as a percentage of maximum output frequency (E1-04).

Function: PID Feedback

Setting: B

Configuring the analog input as PID feedback is a requirement of setting the Drive up for PID operation. The analog input is the only source for feedback for PID operation though the setpoint can come from a number of different sources. Refer to the section covering the PID parameters for more information regarding specifying the setpoint source.

Analog input gain and bias for terminals A2 (H3-10 and H3-11) and A3 (H3-06 and H3-07) can be used to configure the analog input to match the signal from the Feedback Transmitter.

The U1-24 monitor (PID Feedback) can be used to check the PID Feedback level with the digital operator.

Function: PID Set Point

Setting: C

Setting the analog input to PID set point allows the analog input level to be the PID set point as a percentage of maximum output frequency (E1-04). The frequency reference selected in parameter b1-01 no longer becomes the PID set point.

Function: Frequency Bias 2

Setting: D

By setting the analog input to frequency bias 2, a bias signal to the active frequency reference set via A1, A2, or A3.

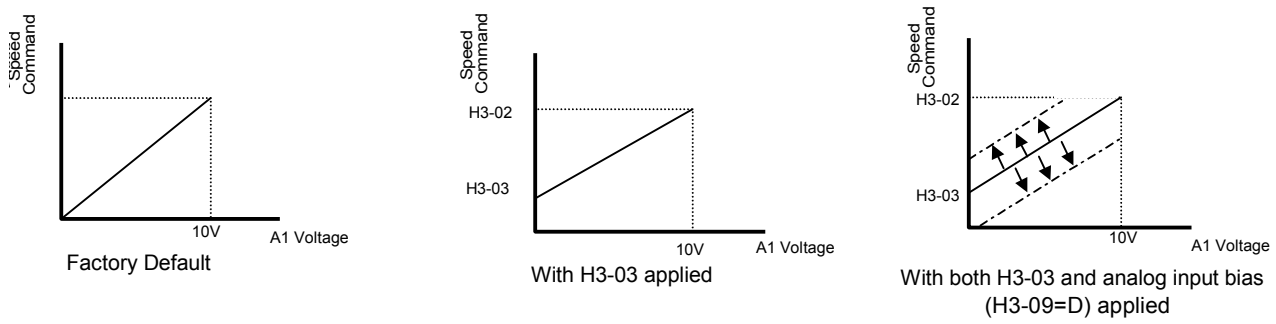

Fig. 71 Frequency Bias 2 Applied to Analog frequency reference

Function: Motor Temperature

Setting: E

In addition to or in place of the OL1 (Motor Overload) fault of the Drive, it is possible to use a PTC (Positive Temperature Coefficient) thermistor for motor insulation protection. The PTC thermistors are built into the windings of some motors and will vary their resistance based on temperature. An example PTC characteristic is show below.

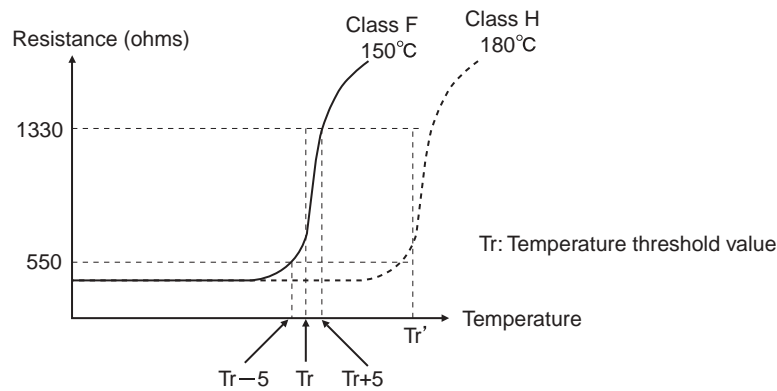
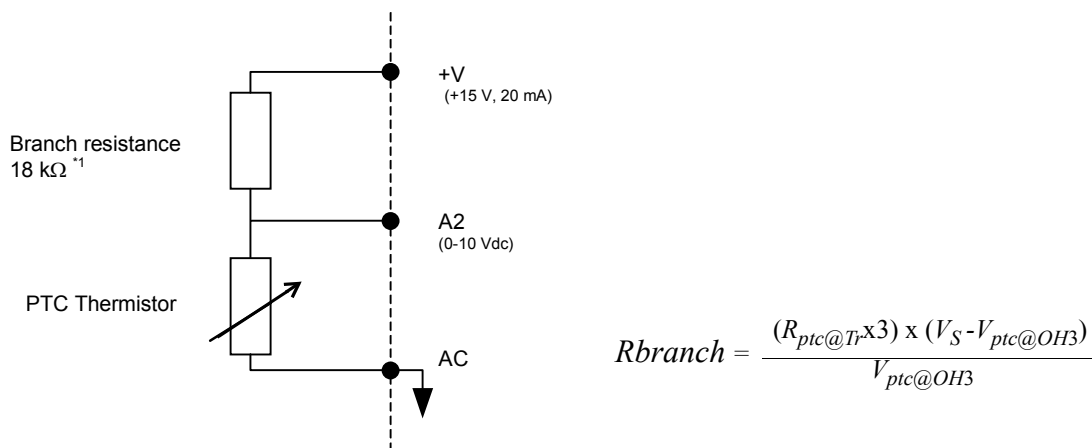

Fig. 72 PTC Thermistor Temperature-Resistance Value Characteristics

Connection of the thermistor to the Drive is shown below, in addition make sure Dip Switch S1-2 is in the OFF position, see Figure 55.



*1 The resistance value of 18 kΩ is only valid for using a 3-phase PTC with the characteristics shown in the figure above.

Fig. 73 Thermistor To Drive Connection Diagram
Programming 102

After the connections are made, configure the A2 analog input for motor temperature protection by setting H3-09= “E: Motor Temperature”. Parameters L1-03, L1-04, and L1-05 set the response to the alarm level being exceeded, response to the fault level being exceeded, and temperature sensing delay time, respectively.

The proper value of the branch resistance is approximated by the formula:

$$R_{branch} = \frac{(R_{ptc@Tr \times 3}) \times (V_S - V_{ptc@OH3})}{V_{ptc@OH3}}$$

Where: $(R_{ptc@Tr} \times 3)$ = The resistance value of the thermistor at either the alarm or fault level adjusted for three phase (three thermistors in series, refer to typical PTC thermistor characteristic in Figure 72).

V_S = The supply voltage (+15Vdc)

$V_{ptc@OH3}$ = The rated voltage for the over-temperature alarm or fault

Function: Fwd Torque Limit
Setting: 10

Function: Rev Torque Limit
Setting: 11

Function: Regen Torque Limit
Setting: 12

Torque limit can be independently set by the analog input programmed for the proper motoring condition (quadrants 1, 2, 3, and 4) as a percentage of motor rated torque.

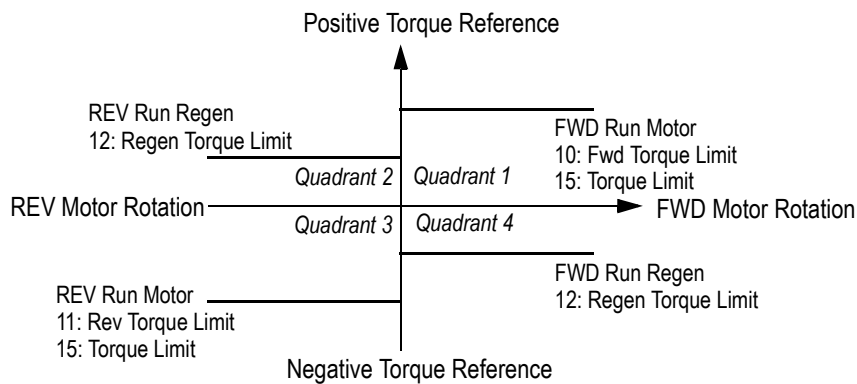

Fig. 74 Analog Input Torque Limit - 4 Quadrant Operation

Function: Torque Reference
Setting: 13

Torque reference (in torque control, d5-01 = 1) or torque limit (in speed control, d5-01 = 0) can be set by the analog input as a percentage of motor rated torque. Torque reference can be set in positive or negative direction.

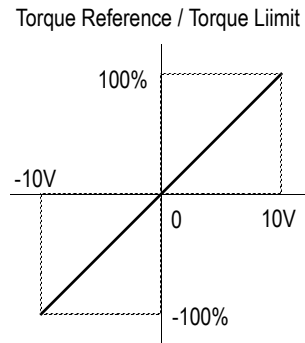

Fig. 75 Torque Reference / Torque Limit

Function: Torque Compensation

Setting: 14

Torque compensation can be utilized by selecting torque compensation for the analog input as a percentage of motor rated torque. See torque control parameters (d5-0x) for details.

Function: Torque Limit

Setting: 15

Torque limit can be set by the analog input programmed torque limit for forward and reverse motoring conditions (quadrants 1 and 3) as a percentage of motor rated torque.

Function: Not Used

Setting: 1F

When H3-09= “1F: Not Used”, any signal applied to the A2 analog input will be ignored by the Drive.

■ **H3-10 Terminal A2 Gain Setting**

Setting Range: 0.0 to 1000.0%
 Factory Default: 100.0%

■ **H3-11 Terminal A2 Bias Setting**

Setting Range: -100.0% to +100.0%
 Factory Default: 0.0%

Parameters H3-10 and H3-11 perform the same function for the A2 analog input that parameters H3-02 and H3-03 perform for the A1 analog input. Please refer to the parameter description for H3-02 and H3-03 for details.

■ **H3-12 Analog Input Filter Time Constant**

Setting Range: 0.0 to 2.00 Seconds
 Factory Default: 0.30 Seconds

An analog input filter can be used to prevent erratic Drive control when a “noisy” analog reference is used. Parameter H3-12 sets the time constant for a first order filter that will be applied to both the A1, A2, and A3 analog inputs. The Drive operation becomes more stable the longer the time programmed, but it becomes less responsive to rapidly changing analog signals.

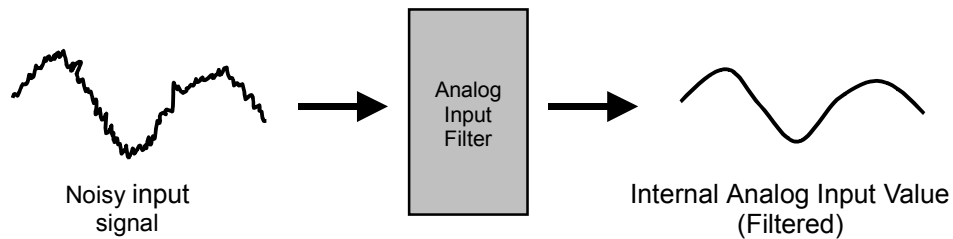

Fig. 76 Analog Input Filter Time Constant Effect on “Noisy” Signal

◆ H4 Analog Outputs

■ H4-01 Terminal FM Monitor Selection

Setting Range: 1 to 45

Factory Default: 2: Output Freq

The FM and AM analog output terminals can be programmed to output a 0 to 10 Vdc, -10 to +10 Vdc, or 4 to 20 mA signal proportional to any one of functions detailed in the table below.

Table 21 Analog Output Functions					
Parameter Setting	Function	Control Method (A1-02)			
		V/f	V/f with PG	Open Loop Vector	Flux Vector
1	Frequency Reference	0	0	0	0
2	Output Frequency	0	0	0	0
3	Output Current	0	0	0	0
5	Motor Speed	X	0	0	0
6	Output Voltage	0	0	0	0
7	DC Bus Voltage	0	0	0	0
8	Output kWatts	0	0	0	0
9	Torque Reference	X	X	0	0
15	Terminal A1 Input Level	0	0	0	0
16	Terminal A2 Input Level	0	0	0	0
17	Terminal A3 Input Level	0	0	0	0
18	Motor Secondary Current	0	0	0	0
19	Motor Excitation Current	X	X	0	0
20	SFS Output	0	0	0	0
21	ASR Input	X	0	X	0
22	ASR Output	X	0	X	0
24	PID Feedback	0	0	0	0
26	Output Voltage Reference Vq	X	X	0	0
27	Output Voltage Reference Vd	X	X	0	0
31	Not Used	0	0	0	0
32	ACR (q) Output	X	X	0	0
33	ACR (d) Output	X	X	0	0

Table 21 Analog Output Functions					
Parameter Setting	Function	Control Method (A1-02)			
		V/f	V/f with PG	Open Loop Vector	Flux Vector
36	PID Input	O	O	O	O
37	PID Output	O	O	O	O
38	PID Setpoint	O	O	O	O
44	ASR Output Without Filter	X	X	X	O
45	Feedforward Control Output	X	X	X	O

The analog output function selections above correspond to one of the same number U1-xx monitors in the Drive.

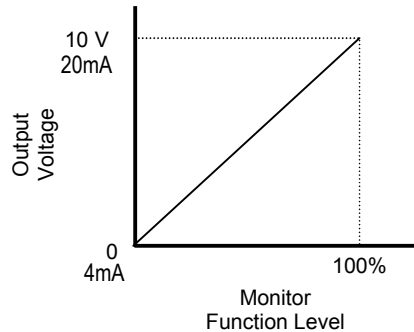

Fig. 77 Analog Output Signal Level as a Function of the Monitor Value

Function: Frequency Reference

Setting: 1

The analog output level will correspond to the chosen frequency reference input whether it is input via the digital operator, analog input, serial communication, option board, or pulse input. 100% will be equivalent to the maximum output frequency of the Drive (E1-04).

Function: Output Frequency

Setting: 2

The analog output level will correspond to the actual Speed being output by the Drive and will include the acceleration and deceleration ramps. 100% will be equivalent to the maximum output frequency of the Drive (E1-04).

Function: Output Current

Setting: 3

The analog output level will correspond to the output current level of the Drive. 100% will be equivalent to the Drives rated output current which is based on the rated capacity of the Drive (o2-04).

Function: Motor Speed

Setting: 5

The analog output level will correspond to the motor speed. 100% will be equivalent to the maximum output frequency of the Drive (E1-04).

Function: Output Voltage

Setting: 6

The analog output level will correspond to the output voltage level of the Drive. 100% will be equivalent to either 200Vac or 400Vac depending on the input voltage rating of the Drive.

Function: DC Bus Voltage

Setting: 7

The analog output level will correspond to the voltage level of the Drive's DC Bus. 100% will correspond to 400Vdc for the 240Vac input Drive and 800Vdc for the 480Vac input Drive.

Function: Output kWatts

Setting: 8

The analog output level will correspond to an internally calculated output power level based on the measured output current and output voltage. 100% will correspond to the kilowatt rating of the Drive as determined by o2-04.

Function: Torque Reference

Setting: 9

The analog output level will correspond to the torque reference. 100% will correspond to the Drive's rated power as determined by o2-04.

Function: Terminal A1 Level

Setting: 15

The analog output level will correspond to the analog input to the Drive's A1 terminal. 100% will be equivalent to 10Vdc.

Function: Terminal A2 Level

Setting: 16

The analog output level will correspond to the analog input to the Drive's A2 terminal. 100% will be equivalent to 10Vdc or 20mA.

Function: Terminal A3 Level

Setting: 17

The analog output level will correspond to the analog input to the Drive's A3 terminal. 100% will be equivalent to 10Vdc.

Function: Motor SEC Current

Setting: 18

The analog output level will correspond to the calculated secondary (torque producing) current. 100% will be equivalent to motor's full load secondary current as calculated by:

$$\begin{aligned} I_{\text{sec}} &= \sqrt{I_{\text{Nameplate}}^2 - I_{\text{no load}}^2} \\ &= \sqrt{(E2-01)^2 - (E2-03)^2} \end{aligned}$$

Function: Mot EXC Current

Setting: 19

The analog output level will correspond to the calculated motor excitation (magnetizing) current. 100% will be equivalent to motor rated magnetizing current.

Function: SFS (Softstart) Output**Setting: 20**

The analog output level will correspond to the frequency reference after the applicable acceleration and deceleration rates are applied. The SFS (Softstart) Output monitor will not include variations to the frequency reference other than the acceleration and deceleration ramps. 100% will be equivalent to the maximum output frequency of the Drive (E1-04).

Function: ASR Input**Setting: 21**

The analog output level will correspond to the automatic speed regulator input. 100% will be equivalent to the maximum output frequency of the Drive (E1-04).

Function: ASR Output**Setting: 22**

The analog output level will correspond to the automatic speed regulator output. 100% will be equivalent to the maximum output frequency of the Drive (E1-04).

Function: PID Feedback**Setting: 24**

The analog output level will correspond to the analog input to the Drive's A2 terminal during normal PID operation but will correspond to the A1 analog input when the A2 analog input is configured as a PID Differential input (H3-09= "16: PID Differential"). The output will function even if PID operation is not selected (b5-01= "0: Disabled"). Parameter b5-20 will apply a gain to the measured analog output voltage before the monitor is displayed. (i.e. with b5-20 = 5 the 2 Vdc feedback signal will generate 10 Vdc on the analog output).

Function: Voltage Ref (Vq)**Setting: 26**

The analog output level will correspond to the voltage reference for the motor secondary current control. 100% will be equivalent to the maximum output voltage of the Drive (E1-05).

Function: Voltage Ref (Vd)**Setting: 27**

The analog output level will correspond to the internal voltage reference for motor excitation current. 100% will be equivalent to the maximum output voltage of the Drive (E1-05).

Function: Not Used**Setting: 31**

When H4-01= "31: Not Used" no voltage is output by the analog output.

Function: ACR (q) Output**Setting: 32**

The analog output level will correspond to the current control output value for the secondary (torque producing) current. 100% will be equivalent to the motor rated secondary current.

Function: ACR (d) Output**Setting: 33**

The analog output level will correspond to the internal voltage reference for motor excitation (magnetizing) current. 100% will be equivalent to the motor rated magnetizing current.

Function: PID Input

Setting: 36

The analog output will correspond to the measured error of the PID function. The measured error of normal PID operation is the setpoint minus the feedback. The measured error of the differential PID is the difference between the A1 and A2 analog inputs summed with the PID differential setpoint). The output will not function unless PID operation is selected (b5-01≠0).

Function: PID Output

Setting: 37

The analog output will correspond to the output of the PID function. The PID output will be measured after any gains, offsets, or limits are applied to the output of the Proportional and Integral factors. The output will not function unless PID operation is selected (b5-01¼0) and there is an active Run command. 100% will be equivalent to maximum frequency (E1-04).

Function: PID Setpoint

Setting: 38

The analog output will correspond to the level of the chosen setpoint of the PID function. Please refer to table 1 included in the section PID Control (b5 parameters) for more information about selecting the PID setpoint source. The output will not function unless PID operation is selected (b5-01¼0).

Function: ASR Out w/o Filter

Setting: 44

The analog output level will correspond to the ASR output level before filtering. 100% will be equivalent to the rated secondary current of the motor.

Function: FF Count Output

Setting: 45

The analog output level will correspond to the feedforward control output. 100% will be equivalent to the rated secondary current of the motor.

■ **H4-02 Terminal FM Gain Setting**

Setting Range: 0.0 to 1000.0%

Factory Default: 100.0%

Refer to parameter H4-03 for description details.

■ **H4-03 Terminal FM Bias Setting**

Setting Range: -110.0% to +110.0%

Factory Default: 0.0%

The gain and bias parameters for the analog outputs of the Drive allow the programmer to customize the output signal for the equipment connected to the output. The analog outputs are adjustable over a range of 0 to 10 Vdc, -10 to +10Vdc, or 4 to 20 mA. The gain settings for the analog outputs determine the output voltage level that will be equivalent to 100% of the Monitor Function Level. A gain setting greater than 100% will produce 10Vdc on the analog output when the monitor function is less than 100%.

For example, if H4-02= 150%, then the FM analog output will produce 6.7Vdc when the assigned output function initially reached the 100% level.

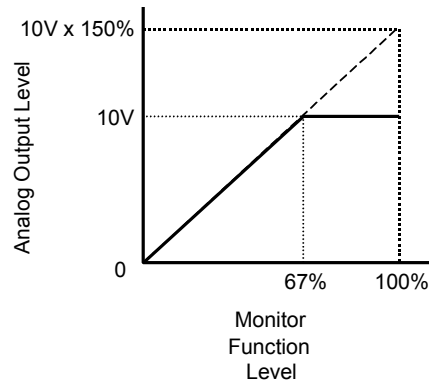

Fig. 78 Analog Output gain Setting Adjustment

Like the bias settings for the analog inputs (H3-03 and H3-11), the bias settings for the analog outputs determine the output function level that will be equivalent to 0Vdc or 4mA.

For example, if H4-03= -25%, then when the output function level is at 0% the FM analog output will output 2Vdc.

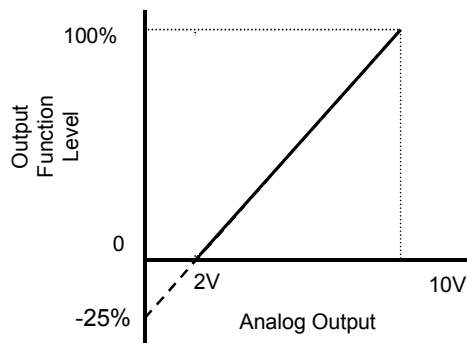

Fig. 79 Analog Output Bias

■ **H4-04 Terminal AM Monitor Selection**

Setting Range: 1 to 45
 Factory Default: 3: Output Current

Refer to parameter H4-01 for description details.

■ **H4-05 Terminal AM Gain Setting**

Setting Range: 0.0 to 1000.0%
 Factory Default: 50.0%

■ **H4-06 Terminal AM Bias Setting**

Setting Range: -110.0% to +110.0%
 Factory Default: 0.0%

Refer to parameters H4-02 & H4-03 for description details.

■ **H4-07 Terminal FM Signal Level Selection**

H4-08 Terminal AM Signal Level Selection

Setting	Description
0	0 to 10 Vdc (<i>factory default</i>)
1	-10 to +10 Vdc
2	4 - 20 mA

Parameters H4-07 and H4-08 determine whether analog outputs are configured as 0 to 10Vdc, -10 to +10Vdc, or 4-20mA. The jumper position of CN15 on the removable terminal board must correspond to the parameter setting for the proper voltage or current level output.

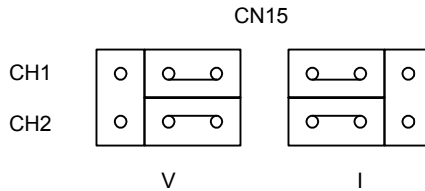

Fig. 80 Jumper CN15

Table 22 Jumper CN15		
Name	Multi-function Analog Output	Output Range
CH1	FM	V: 0 to 10V or -10V to +10V (default) I: 4 to 20mA
CH2	AM	V: 0 to 10V or -10V to +10V (default) I: 4 to 20mA

◆ **H5 Serial Communication Setup**

This section explains the parameters associated with Modbus Serial Communication. Serial communication can be performed with Programmable Logic Controllers (PLCs) or similar devices using the Modbus protocol. Modbus communication is configured using 1 master (PLC) and a maximum of 31 slaves. Serial communication between master and slave is normally initiated by the master and responded to by the slaves. The master performs serial communication with one slave at a time. Consequently, the slave address of each slave must be initially set, so that the master can perform serial communication using that address. Slaves receiving commands from the master perform the specified functions, and send a response back to the master.

See F7 Drive Users Manual TM.F7.01 Appendix D for further details on setting up Modbus Communication.

■ **H5-01 Drive Node Address**

Setting Range: 0 to 20 hex

Factory Default: 1F hex

In order for a master to be able to communicate with the Drive using serial communications, the Drive must have a unique node address. The Drive is given a node address if H5-01≠0. The node addresses do not have to be assigned in sequential order but they must be unique, i.e. no two Drives on the same serial network can be assigned the same address. After setting the Drive address with the H5-01 parameter, the power to the Drive must be cycled for the addressing to take effect.

Leaving H5-01= 0 will disable responses to MEMOBUS communications.

■ H5-02 Communications Speed Selection

Setting	Description
0	1200 Baud
1	2400 Baud
2	4800 Baud
3	9600 Baud (<i>factory default</i>)
4	19200 Baud

■ H5-03 Communications Parity Selection

Setting	Description
0	No Parity (<i>factory default</i>)
1	Even Parity
2	Odd Parity

Parameters H5-02 and H5-03 configure the Drives MEMOBUS communications via the RS-485/422 terminals on the removable terminal block. Configure H5-02 and H5-03 to match the settings of the master controller of the serial network. After changing the H5-02 or H5-03 parameter, the power to the Drive must be cycled for the change to take effect.

If either the speed or parity value is changed via the serial communications, the serial communications will cease to operate until the Drive power is cycled.

It may be necessary to avoid the 19.2 K baud setting if frequent serial communications errors occur at that baud rate.

■ H5-04 Stopping Method After Communication Error

Setting	Description
0	Ramp to Stop
1	Coast to Stop
2	Fast-Stop
3	Alarm Only (<i>factory default</i>)

The setting of parameter H5-04 will determine the Drive's reaction to a serial communications fault such as the CE fault. The Drive can be programmed to either ramp to a stop in the time specified by C1-02 (H5-04= "0: Ramp to stop"), coast to a stop (H5-04= 1), ramp to a stop at the special fast stopping time specified by C1-09 (H5-04= "2: Fast-Stop"), or continue operating using the commands received before the serial communication fault and flashing an alarm on the digital operator (H5-04= "3: Alarm Only").

■ **H5-05 Communications Error Detection Selection**

Setting	Description
0	Disabled
1	Enabled (<i>factory default</i>)

The Drive can be configured by parameter H5-05 to recognize a CE fault whenever serial communications time-out. If H5-05= “1: Enabled”, the Drive will fault if serial communication responses are not received within 2 seconds. Drive power should be cycled after a change is made to this parameter.

■ **H5-06 Drive Transit Wait Time**

Setting Range: 5 to 65 ms
 Factory Default: 5 ms

Parameter H5-06 will set the delay time between the receiving of a message from the master and the sending of a response from the Drive back to the master. Drive power should be cycled after a change is made to this parameter.

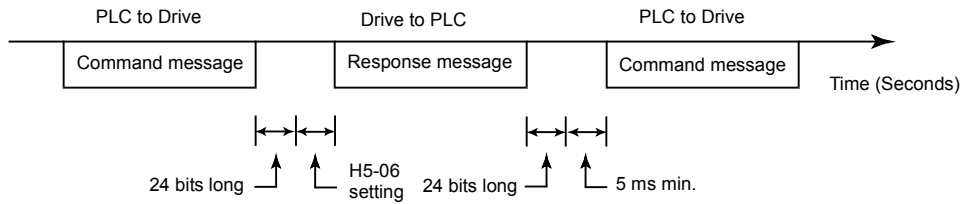

Fig. 81 Message Spacing

■ **H5-07 RTS Control Selection**

Setting	Description
0	Disabled (RTS is always on)
1	Enabled (RTS turns on only when sending) (<i>factory default</i>)

RTS or Request To Send control is a method of flow control applied to messaging in serial communications. Parameter H5-07 configures whether the Drive will implement RTS messaging all the time (H5-07= “0: Disabled”) or only when sending (H5-07= “1: Enabled”). It is recommended to set H5-07= “0: Disabled”, when using RS-485 and set H5-07= “1: Enabled”, when using RS-422. Drive power should be cycled after a change is made to this parameter.

◆ H6 Pulse I/O Setup

The Drive has the ability to receive and output a single-ended pulse train. The pulse train input and output is not quadrature and therefore cannot be used to sense or transmit direction (phase) information. Please pay attention to the wiring diagrams in the F7 Drive User's Manual (TM.F7.01) to avoid potential damage to the Drive and external circuitry. Proper circuit impedance must be used to avoid either an unrecognizable pulse train signal or a high current condition that could damage equipment.

The input, which can handle up to a 32 kHz signal, is scalable and can be programmed for frequency reference and PID functions. To use the pulse input as the frequency reference, set b1-01 = 4 and H6-01 = 0. For PID functions, set H6-01 = 1 for PID feedback or H6-01 = 2 for PID setpoint.

The output monitor, which can be used in sinking or sourcing installations, is also scalable up to a 32 kHz frequency and can be programmed to be proportional to the Drive's monitors relating to frequency, speed, and the PID functions. To program the output, set the appropriate U1 monitor number in H6-06. The monitor can also be synchronized in phase with the Drive's T1-phase output frequency by setting H6-06 = 2 and H6-07 = 0.

■ H6-01 Pulse I/O Setup

Setting	Description
0	Frequency Reference (<i>factory default</i>)
1	PID Feedback Value
2	PID Setpoint Value

This parameter selects the function of the pulse train terminal RP. If pulse train is to be used as the frequency reference (H6-01 = 0) parameter b1-01 must be set to 4: Pulse Input.

■ H6-02 Pulse In Scaling

Setting Range: 1000 to 3200 Hz

Factory Default: 1440 Hz

Pulse train input scaling parameter sets the number of pulses (in Hz) that is equal to the maximum output frequency E1-04.

■ H6-03 Pulse Input Gain

Setting Range: 0.0 to 1000.0 %

Factory Default: 100.0 %

Pulse train input gain sets the output level with the pulse train input is at 100% as a percentage of maximum output frequency (E1-04).

■ H6-04 Pulse Input Bias

Setting Range: -100.0 to 100.0 %

Factory Default: 0.0 %

Pulse train input bias sets the output level when the pulse train input is 0 Hz as a percentage of maximum output frequency (E1-04).

■ H6-05 Pulse In Filter

Setting Range: 0.00 to 2.00 sec

Factory Default: 0.10 sec

Sets the pulse train input filter time constant in seconds.

■ H6-06 Pulse Monitor Selection

Setting Range: 1, 2, 5, 20, 24, 31, 36

Factory Default: 2

Selects the pulse train monitor output terminal MP function (value of the xx part of monitor U1-xx). See Appendix A for a complete list of monitors.

■ H6-07 Pulse Monitor Scale

Setting Range: 0 to 32000 Hz

Factory Default: 1440 Hz

Pulse train monitor scaling sets the number of output pulses when the monitor is 100% (in Hz). Set H6-06 to 2 and H6-07 to 0 to make the pulse train monitor output synchronous to the output frequency.

◆ L1 Motor Overload

■ L1-01 Motor Overload Protection Selection

Setting	Description
0	Disabled
1	Std Fan Cooled (< 10:1 motor) (<i>factory default</i>)
2	Standard Blower Cooled (\geq 10:1 motor)
3	Vector Motor (\geq 1000:1 motor)

The Drive has an electronic overload protection function (OL1) for protecting the motor from overheating. The Drive bases the protection on time, output current, and output frequency. The electronic thermal overload function is UL-recognized, so an external thermal overload relay is not required for single motor operation.

This parameter selects the motor overload curve used according to the type of motor applied.

Setting L1-01 = 1 selects a motor with limited cooling capability below rated (base) speed when running at 100% load. The OL1 function derates the motor any time it is running below base speed.

Setting L1-01 = 2 selects a motor capable of cooling itself over a 10:1 speed range when running at 100% load. The OL1 function derates the motor when it is running at 1/10 of its rated speed or less.

Setting L1-01 = 3 selects a motor capable of cooling itself at any speed when running at 100% load. This includes zero speed. The OL1 function does not derate the motor at any speed.

If the Drive is connected to a single motor, the motor overload protection should be enabled (L1-01=1, 2, or 3) unless another means of preventing motor thermal overload is provided. When the electronic thermal overload function is activated, an OL1 fault occurs, shutting OFF the Drive's output thus preventing additional overheating of the motor. The motor temperature is continually calculated as long as the Drive is powered up.

IMPORTANT

If the Drive is connected to more than one motor for simultaneous operation, the electronic overload protection should be disabled (L1-01= "0: Disabled") and each motor should be wired with its own motor thermal overload.

■ **L1-02 Motor Overload Protection Time**

Setting Range: 0.1 to 20.0 Minutes
 Factory Default: 8.0 Minutes

The L1-02 parameter will set the allowed operation time before the OL1 fault will occur when the Drive is running at 60 Hz and 133% of the motor’s full load amp rating (E2-01). Adjusting the value of L1-02 can shift the set of OL1 curves up the Y-axis of the diagram below but will not change the shape of the curves.

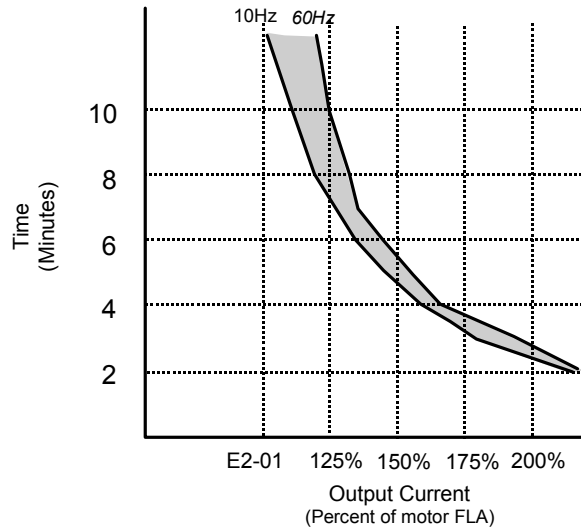

Fig. 82 Motor Overload Protection Time based on Output frequency and Load

■ **L1-03 Motor Overheat Alarm Operation Selection**

Setting	Description
0	Ramp to Stop
1	Coast to Stop
2	Fast-Stop
3	Alarm Only (<i>factory default</i>)

■ **L1-04 Motor Overheat Fault Operation Selection**

Setting	Description
0	Ramp to Stop
1	Coast to Stop (<i>factory default</i>)
2	Fast-Stop

■ **L1-05 Motor Temperature Input Filter Time**

Setting Range: 0.00 to 10.00 Seconds
 Factory Default: 0.20 Seconds

The Drive can be programmed to accept a PTC (Positive Temperature Coefficient) Thermistor input for monitoring motor temperature. By setting parameter H3-09= “E: Motor Temperature”, and attaching the PTC thermistor per the figure below, the Drive can react to the increasing motor winding temperature with both an alarm (L1-03) and a fault (L1-04).

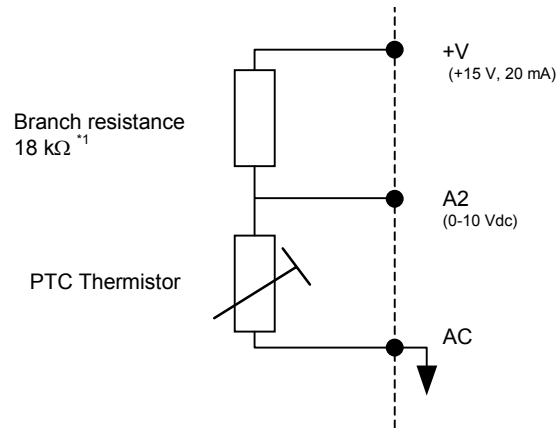

*1 The resistance value of 18 kΩ is only valid for using a 3-phase PTC with the characteristics shown in the figure on following page.

Fig. 83 Thermistor Wiring

A typical PTC Thermistor characteristic shown on the following page.

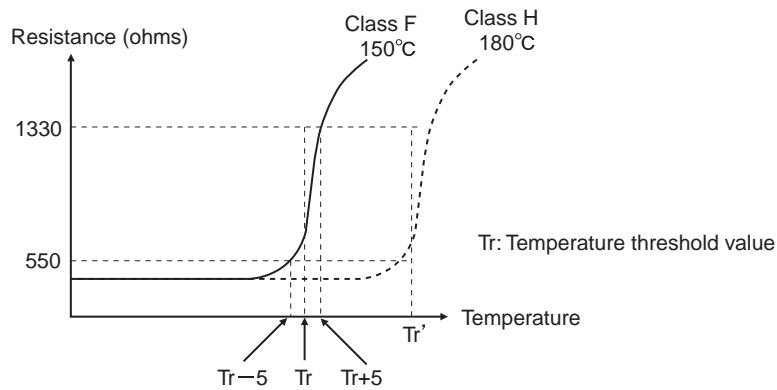

Fig. 84 PTC Thermistor Temperature-Resistance Value Characteristics

Using the changing voltage drop across the thermistor the voltage into the A2 analog input will vary according to the motor's winding temperature. If the measured voltage into A2 exceeds 1.17Vdc the Drive will flash an OH3 alarm on the digital operator and will either ramp to a stop in the time specified by C1-02 (L1-03= "0: Ramp to Stop"), coast to a stop (L1-03= "1: Coast to Stop"), ramp to a stop at the special fast stopping time specified by C1-09 (L1-03= "2: Fast-Stop"), or continue operating using the commands received before the OH3 alarm (L1-03= "3: Alarm Only"). The Drive's fault contact, MA-MB, will not close.

If the measured voltage into the A2 analog input exceeds 2.34Vdc the Drive will fault (OH4) and either ramp to a stop in the time specified by C1-02 (L1-04= "0: Ramp to Stop"), coast to a stop (L1-04= "1: Coast to Stop"), ramp to a stop at the special fast stopping time specified by C1-09 (L1-04= "2: Fast-Stop"). The Drive's fault contact, MA-MB, will close.

Parameter L1-05 will apply a time delay filter to the A2 analog input when it is configured as the thermistor input. The greater the time programmed into L1-05 the less responsive the Drive will be to quick changes to the input voltage but the more stable the input will be. A noisy input will benefit from a greater L1-05 time.

◆ L2 Momentary Power Loss Ride-thru Function

When momentary power loss recovery is enabled (L2-01≠0), a speed search is executed to catch the potentially spinning motor shaft. This speed search will occur regardless of the setting of b3-01 “Speed Search Selection”.

■ L2-01 Momentary Power Loss Detection Selection

Setting	Description
0	Disabled
1	Power Loss Ride Thru Time
2	CPU Power Active (<i>factory default</i>)

■ L2-02 Momentary Power Loss Ride-Thru Time

Setting Range: 0.0 to 25.5 Seconds

Factory Default: Model Dependent

The Drive allows different responses to momentary power losses. The setting of L2-01 determines whether the Drive attempts to restart after a short loss of incoming AC power and for what length of time this capability remains active.

If L2-01= “0: Disabled”, the Drive detects a UV1 fault 15ms after power loss and automatic restarting is disabled. The Drive cannot restart until the external run command is removed and the UV1 fault is reset.

If L2-01= “1: PwrL Ride Thru t”, the Drive restarts without the UV1 fault if power is returned within the time specified in L2-02, the Momentary Power Loss Ride-thru Time. During the power loss but before the fault trip, the digital operator will display a UV alarm. If L2-02 is set for a time longer than the control power supply can be sustained, a UV1 fault will not occur and the Drive restarts upon the return of AC power. The time that the control power supply can be maintained varies with Drive size. The larger the Drive is, the greater the potential ride-thru time.

If L2-01= “2: CPU Power Active”, the Drive ignores L2-02 and attempts a restart as long as the control power supply is still able to maintain a minimal voltage level. In effect, setting L2-01= “2: CPU Power Active” (factory default) is programming the Drive for maximum Power Loss Ride-thru. An equivalent setting is L2-01= “1: PwrL Ride Thru t”, with L2-02 set to a time longer than the control power supply can be maintained after power is lost.

Note: The run command must be held during power loss for any power loss ride-thru capability to be possible. It is for this reason that 3-wire control is not recommended for use with the Momentary Power Loss function.

■ L2-03 Momentary Power Loss Minimum Baseblock Time

Setting Range: 0.1 to 5.0 Seconds

Factory Default: Model Dependent

When momentary power loss recovery is enabled (L2-01≠0) the Drive will baseblock for a period of time specified by the L2-03 parameter. The baseblock time will be executed just prior to the speed search function in order to allow any residual magnetic fields in the motor windings to decay before any new voltage is applied to the motor.

If the motor’s secondary circuit time constant is known, set L2-03= 0.7x (value of time constant). If an OC or OV fault occurs during momentary power loss recovery, increase the setting of L2-03.

The L2-03 parameter also sets the baseblock time for the DC Injection Braking function (b1-03= “2: DC Injection to Stop”). If an OC or OV fault occurs during DC Injection Braking to Stop, increase the setting of L2-03.

■ L2-04 Momentary Power Loss Voltage Recovery Ramp Time

Setting Range: 0.0 to 5.0 Seconds

Factory Default: Model Dependent

When momentary power loss recovery is enabled (L2-01≠0), a speed search is executed to catch the potentially spinning motor shaft. As part of the speed search function full voltage is not immediately applied to the motor but is ramped up.

The setting of parameter L2-04 determines the ramp time for increasing the output voltage from zero to maximum voltage (E1-05).

If a UV1 fault occurs during the current detection speed search function, increase the setting of L2-04.

■ L2-05 Undervoltage Detection Level

Setting Range: 150 to 210 Vdc (240V Class), 300 to 420 Vdc (480V Class)

Factory Default: 190 Vdc (240V Class), 380 Vdc (480V Class)

The L2-05 parameter sets the DC Bus undervoltage level. The setting of L2-05 affects the voltage at which a UV alarm or a UV1 fault will occur. If the setting of L2-05 is lowered below the factory default level (190Vdc for a 240Vac drive and 380Vdc for a 480Vac drive), then an AC Input Reactor must be installed on the input AC line to prevent inrush current from damaging the Drive's input diodes. An AC Line dip and fast voltage recovery can potentially cause a large inrush current.

■ L2-06 KEB Deceleration Time

Setting Range: 0.0 to 200.0 sec

Factory Default: 0.0 sec

This parameter sets the time required to decelerate to zero speed when a KEB command is input (H1-0x = 65 or 66).

■ L2-07 UV Recovery Time

Setting Range: 0.0 to 25.5 sec

Factory Default: 0.0 sec

Sets the time to accelerate to the set speed after recovery from a momentary power loss. If this parameter is set to zero, then active accelerate time is used instead.

■ L2-08 KEB Frequency

Setting Range: 0 to 300 %

Factory Default: 100 %

This parameter allows for the setting load inertia ridethru level, as a percentage of output frequency. This setting is used in conjunction with multi-function digital input set for KEB ridethru (H1-0x = 65 or 66), after momentary power loss. When KEB frequency constant is set to zero, KEB ridethru functions as normal, to maintain a controlled deceleration rate for the longest time possible, during momentary power loss. When the KEB frequency is set to any value other than zero, KEB ridethru for systems use is enabled.

◆ L3 Stall Prevention

■ L3-01 Stall Prevention Selection During Accel

Setting	Description
0	Disabled
1	General Purpose (<i>factory default</i>)
2	Intelligent

■ L3-02 Stall Prevention Level During Acceleration

Setting Range: 0 to 200% of Drive rated output current

Factory Default: 120% of Drive rated output current

The stall prevention during acceleration function adjusts the acceleration time in order to prevent OC fault trips during acceleration. If L3-01=“0: Disabled”, stall prevention is disabled and if the load is large enough and the acceleration time short enough the Drive may fault and stop.

If L3-01=“1: General Purpose”, then the standard stall prevention function is enabled. When the output current exceeds the level set by the L3-02 parameter, the Drive will discontinue accelerating altogether and maintain speed. If, during acceleration, the output current comes within 15% of the level set by parameter L3-02, the acceleration rate is lengthened. Once the output current level has dropped below the L3-02 level, acceleration will begin again with the acceleration rate reaching the programmed rate once again 15% below the L3-02 level.

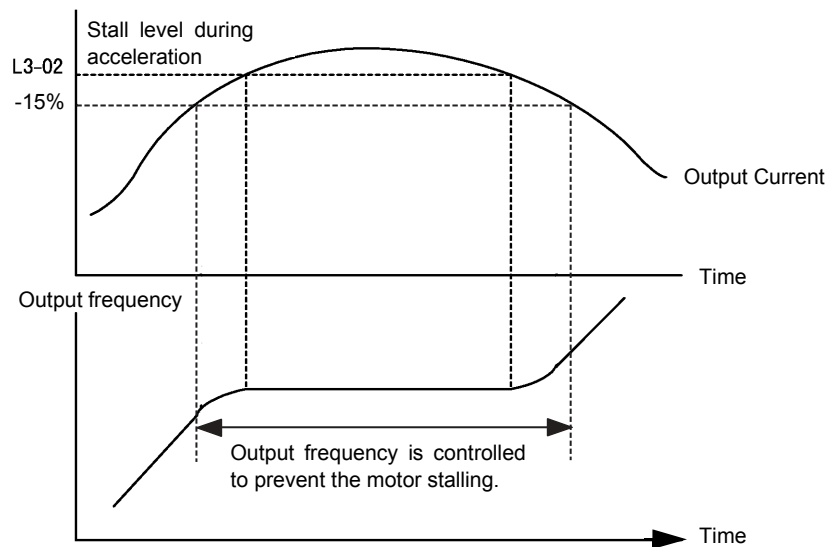

Fig. 85 Detailed Time Chart for Stall Prevention During Acceleration

If L3-01=“2: Intelligent”, the intelligent stall prevention is enabled. The active acceleration time is ignored and the Drive will attempt to accelerate as quickly as possible without exceeding the L3-02 output current level.

IMPORTANT | Stall Prevention during Acceleration is not effective when the output frequency is less than 6Hz.

The following figure demonstrates acceleration when L3-01= “1: General Purpose”.

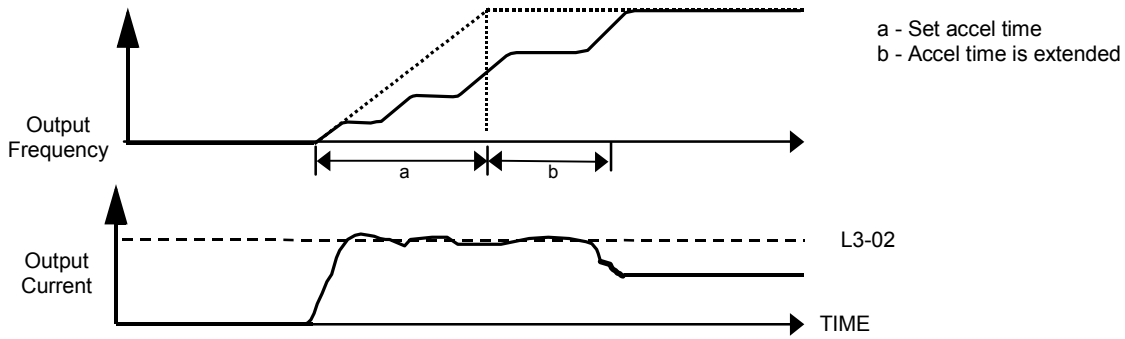

Fig. 86 Time Chart for Stall Prevention During Acceleration

The L3-02 parameter is set as a percentage of the Drive rated output current. If the motor capacity is small compared to the Drive’s capacity, or if the motor stalls during acceleration, lower the set value of L3-02.

■ **L3-03 Stall Prevention Limit During Acceleration Above Constant Horsepower Level**

Setting Range: 0 to 100 %
 Factory Default: 50 %

Sets the lower limit for stall prevention during acceleration, as a percentage of the Drive’s rated current, when operation is in the frequency range above E1-06 (constant horsepower region).

■ **L3-04 Stall Prevention Selection During Deceleration**

Setting	Description
0	Disabled
1	General Purpose (<i>factory default</i>)
2	Intelligent
3	Stall Prevention with Resistor

The stall prevention during deceleration function adjusts the deceleration time in order to prevent OV fault trips during deceleration. If L3-04=0, stall prevention is disabled, and if the load is large and the deceleration time short enough, the Drive may fault and stop.

If L3-04=1, the standard stall prevention function is enabled. If, during deceleration, the DC Bus voltage exceeds the stall prevention level (see table below), the Drive will discontinue decelerating and maintain speed. Once the DC Bus voltage has dropped below the stall prevention level, deceleration will continue. Fig 5.11 demonstrates deceleration when L3-04=1.

Drive Voltage		Stall Prevention Level during Deceleration
240Vac		380Vdc
480Vac	E1-01 ≥ 400Vac	760Vdc
	E1-01 < 400Vac	660Vdc

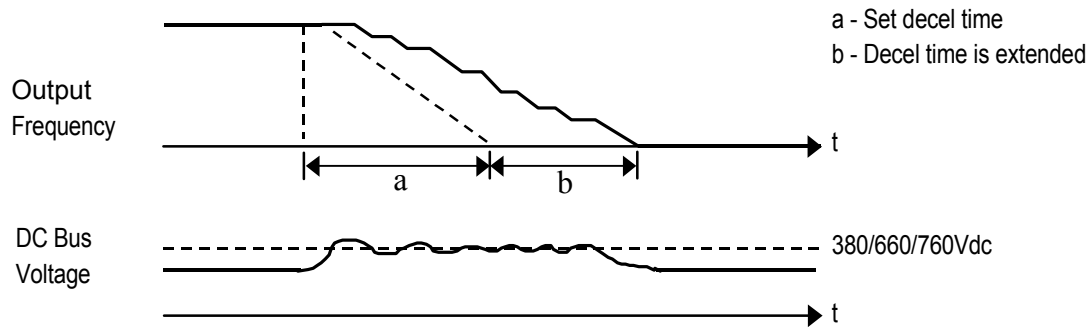

Fig. 87 Stall Prevention

If L3-04=2, the intelligent stall prevention function is enabled. The active deceleration time is used as a starting point and the Drive will attempt to decelerate as quickly as possible without causing the DC Bus voltage to exceed the stall prevention level. The fastest time possible is 1/10 the active deceleration time.

If L3-04=3, the stall prevention with braking resistor function is enabled. The DC bus voltage level is controlled during fast deceleration and allows for a faster than normal deceleration time. Use this setting with a braking resistor when overvoltage fault (OV) sometimes occurs even under settings 1 or 2.

IMPORTANT | In Flux Vector Control Mode (A1-02=3), setting stall prevention with DB resistor (L3-04=3) cannot be done.

■ L3-05 Stall Prevention Selection During Running

Setting	Description
0	Disabled
1	Decel Time 1 (<i>factory default</i>)
2	Decel Time 2

■ L3-06 Stall Prevention Level During Running

Setting Range: 30 to 200% of Drive rated output current

Factory Default: 120% of Drive rated output current

The Stall Prevention During Running function will attempt to avoid a Drive OC fault occurrence while the Drive is operating at a constant speed. If L3-05= “0: Disabled”, the Drive may fault if the load increases sufficiently to cause the output current to reach the OC fault level (180% of Drive rated output current).

If L3-05= “1: General Purpose”, the Drive is outputting a constant speed, and the Drive’s output current level exceeds the level set by parameter L3-06 for more than 100 ms the Drive will begin to decelerate at the rate specified by parameter C1-02. The Drive will continue to decelerate until the output current level drops below the L3-06 level (less a 2% hysteresis). Once the output current drops below the L3-06 – 2% level the Drive will begin to accelerate at the currently active acceleration rate (either C1-01 or C1-03).

If L3-05= “2: Decel Time 2”, the Drive will function as described above except C1-04 will be used instead of C1-02 as the deceleration rate used when the output current exceeds L3-06 for more than 100 ms.

The following figure demonstrates acceleration when L3-05≠0.

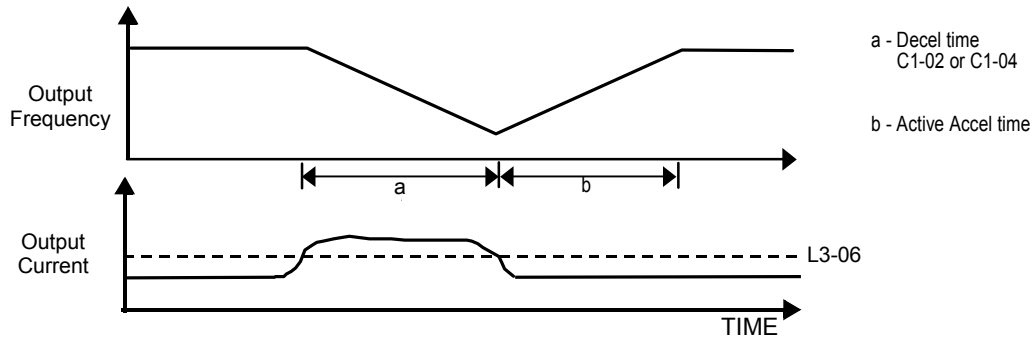

Fig. 88 Time Chart for Stall Prevention Level During Running

The L3-06 parameter is set as a percentage of the Drive rated output current. If the Drive still faults when L3-05≠0, then either lower the L3-06 or adjust the C1-02 or C1-04 settings for a quicker deceleration.

■ L3-11 OV Suppression Function Selection

Setting	Description
0	Disabled (<i>factory default</i>)
1	Enabled

■ L3-12 OV Suppression Function Voltage Level

Setting Range: 350 to 390 Vdc (240V Class), 700 to 780 Vdc (480V Class)

Factory Default: 380Vdc (240 V Class), 760Vdc (480V Class)

This function suppresses a rise in the DC bus voltage caused by applications that have a cyclic regenerative load. This is accomplished by lowering the regenerative torque limit in response to a rise in the DC bus voltage level. Parameter L3-11 enables or disables OV suppression function. When the DC bus voltage is less than the L3-12 minus 30Vdc level, the regenerative torque limit value remains as set. If the DC bus voltage equals the L3-12 minus 30Vdc level, the regenerative torque limit value is cut in half. If the DC bus voltage exceeds the L3-12 level, the regenerative torque limit is set to zero. Between the L3-12 minus 30Vdc and L3-12 levels, the regenerative torque limit value is reduced in proportion to the DC bus voltage.

The OV suppression function is enabled only for open loop vector and flux vector (A1-02 = 2 or 3). This function should be disabled for applications requiring precise speed regulation or precise stopping times as the motor speed could change based on the reduced torque limit. Use a dynamic braking transistor/resistor instead to dissipate the regenerative energy. This function works best when the motor operates in its constant torque area.

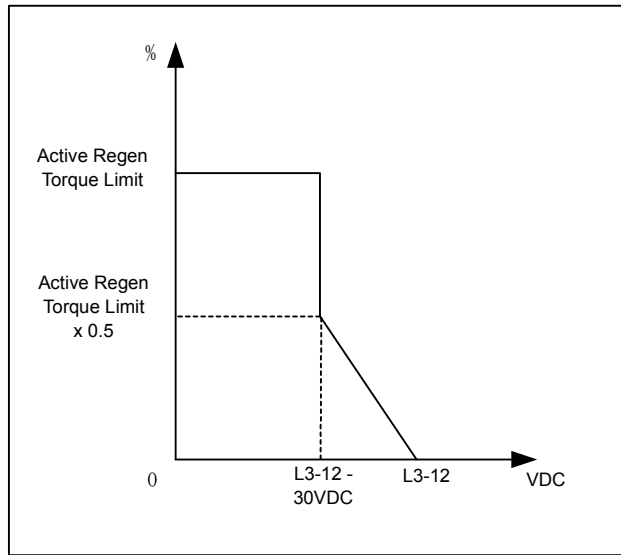

Fig. 89 Time Chart for Stall Prevention Level During Running

◆ L4 frequency reference Loss Detection

■ L4-01 Speed Agreement Detection Level

Setting Range: 0.0 to 400.0 Hz
 Factory Default: 0.0 Hz

■ L4-02 Speed Agreement Detection Width

Setting Range: 0.0 to 20.0 Hz
 Factory Default: 2.0 Hz

Parameters L4-01 and L4-02 are user specified levels for use with the Fref/Fout Agree 1, Fref/Set Agree 1, and Freq Detect 1 & 2 digital output functions. Please refer to the section regarding the H2 Digital Outputs for more information.

■ L4-03 Speed Agreement Detection Level (+/-)

Setting Range: 0.0 to 400.0 Hz
 Factory Default: 0.0 Hz

■ L4-04 Speed Agreement Detection Width (+/-)

Setting Range: 0.0 to 20.0 Hz
 Factory Default: 2.0 Hz

Parameters L4-03 and L4-04 are user specified levels for use with the Fref/Fout Agree 2, Fref/Set Agree 2, and Freq Detect 3 & 4 digital output functions. Please refer to the section regarding the H2 Digital Outputs for more information.

■ L4-05 Frequency Reference Loss Detection Selection

Setting	Description
0	Disabled
1	Enabled @ % of PrevRef (<i>factory default</i>)

■ L4-06 Frequency Reference at Loss of Frequency Reference

Setting Range: 0.0 to 100.0% of previous frequency reference

Factory Default: 80.0% of previous frequency reference

The Drive can be configured to compensate for the loss of its external frequency reference. An external frequency reference is considered lost if it drops 90% of its value in 400mS or less.

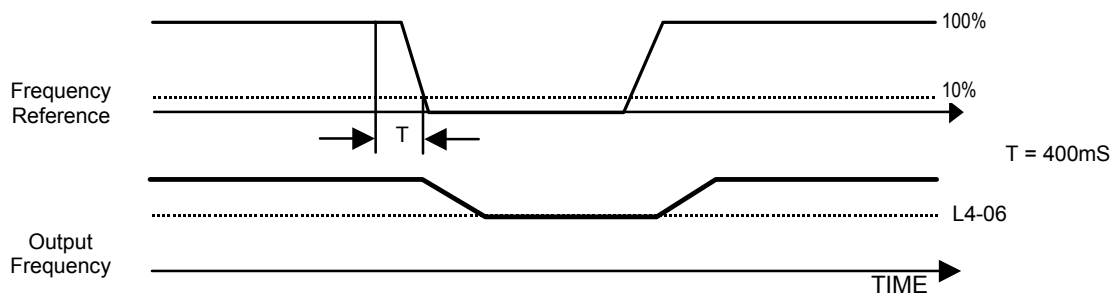

Fig. 90 Loss of Frequency Reference Timing Diagram

To enable Frequency loss detection, set L4-05= "1: Enabled @ % of PrevRef". If Frequency Reference Loss Detection is enabled and the reference is lost, the Drive continues to operate at the frequency referenced by parameter L4-06. When the frequency reference returns, the Drive again follows the frequency reference.

Setting H2-01/H2-02= "C: Loss of Ref", configures a digital output as a Frequency Reference Loss indication only when L4-05= "1: Enabled @ % of PrevRef".

◆ L5 Fault Restart

■ L5-01 Number of Auto Restart Attempts

Setting Range: 0 to 10

Factory Default: 0

■ L5-02 Auto Restart Operation Selection

Setting	Description
0	No Fault Relay (<i>factory default</i>)
1	Fault Relay Active

All major faults will cause the Drive to stop. For some faults it is possible to configure the Drive to attempt a restart automatically. After the fault occurs, the Drive baseblocks for L2-03 seconds. After the baseblock is removed the Drive checks if a fault condition still exists. If no fault condition exists the Drive will attempt to restart the motor. If the restart is successful, the

Drive performs a Speed Search (Regardless of the status of b3-01 “Speed Search Selection”) from the set frequency reference and the Auto Restart Attempts count is increased by one. Even if the restart fails the auto restart count (L5-01) is increased by one as long as the Drive attempted to rotate the motor. The auto restart count will not be incremented if the restart is not attempted due to a continuing fault condition, (i.e. an OV fault). The Drive will scan for a fault condition every 5 ms.

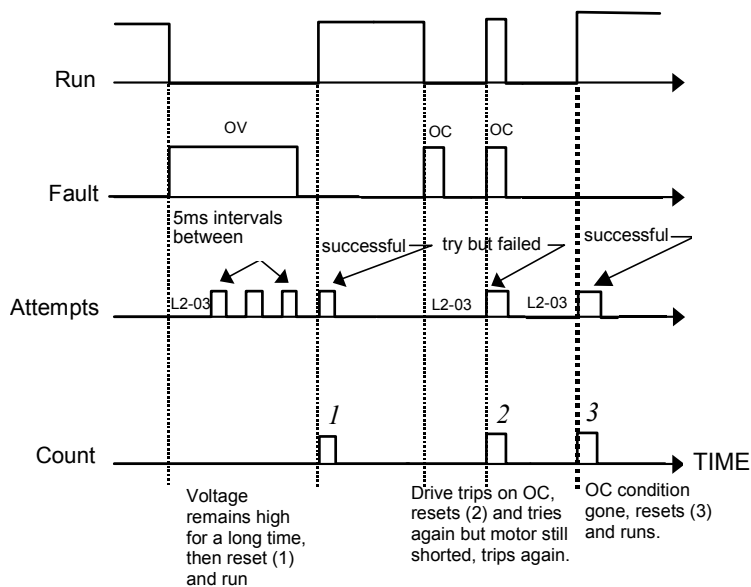

Fig. 91 Automatic Restart Timing Diagram

The auto restart count is reset back to 0 if any of the following occur:

- No further faults for ten minutes after the last retry.
- The Drives power is turned off (the Drive must be without power long enough to let control power dissipate).
- The SHIFT/RESET key is pushed after the last reset attempt.

The setting of parameter L5-02 determines whether the fault output (MA-MB) will be closed during an auto restart attempt. The setting of L5-02 can be important when interfacing the Drive with other equipment.

The following faults will allow the Auto Restart function to initiate:

- OC (Overcurrent)
- LF (Output Open Phase)
- PF (Input Phase Loss)
- PUF (DC Bus Fuse)
- OL1 (Motor Overload)
- OL3 (Overtorque 1)
- OL2 (Drive Overload)
- OL4 (Overtorque 2)
- OV (DC Bus Overvoltage)
- GF (Ground Fault)
- UV1 (DC Bus Undervoltage)
- RH (Braking Resistor)
- RR (Braking Transistor)
- OH1 (Overheat)

In order for auto restart after a UV1 fault, Momentary Power Loss Ride-thru must be enabled (L2-01= “1: PwrL Ride Thru t”, or “2: CPU Power Active”). Setting H2-01 or H2-02 equal to “1E” configures a digital output as “Restart Enabled” to signal if an impending auto restart is possible.

◆ L6 Torque Detection

■ L6-01 Torque Detection Selection 1

Setting	Description
0	Disabled (<i>factory default</i>)
1	OL3 at Speed Agree - Alarm
2	OL3 at Run - Alarm
3	OL3 at Speed Agree - Fault
4	OL3 at Run - Fault
5	UL3 at Speed Agree - Alarm
6	UL3 at Run - Alarm
7	UL3 at Speed Agree - Fault
8	UL3 at Run - Fault

■ L6-02 Torque Detection Level 1

Setting Range: 0 to 300% of Drive rated output current

Factory Default: 150% of Drive rated output current

■ L6-03 Torque Detection Time 1

Setting Range: 0.0 to 10.0 Seconds

Factory Default: 10.0 Seconds

The Drive can be programmed to indicate when either an overtorque or an undertorque conditions exist. A digital output must be programmed for torque detection 1, (H2-0x = “B: Torque Detection 1 N.O.” or “17: Torque Detection 1 N.C.”). A warning of an overtorque condition can indicate a jam and an undertorque condition can indicate a broken belt, no water in a pump, or other loss of load.

To configure Torque Detection requires the following decisions:

1. Do you wish to check for an overtorque condition or an undertorque condition?
2. Do you wish to check for the torque condition whenever the drive is running or only at speed agree? Nuisance detection during acceleration, when variable torques are normally required, can be avoided.
3. Do you want the drive to fault if the torque condition is detected or only alarm and continue operation?

The following table can help choose the proper setting for Torque Detection Selection 1 to get the wanted results.

L6-01 Setting	Overtorque	Undertorque	Fault	Alarm	Always Detected	Only Detected @ Speed Agree
0	Torque Detection Disabled					
1	X			X		X
2	X			X	X	
3	X		X			X
4	X		X		X	
5*		X		X		X
6		X		X	X	
7		X				X
8		X			X	

*Suggested settings for Loss of Load indication

After selecting the proper detection scheme the Torque Detection Level (L6-02) must be specified. If the current level read by the output current transformers rises above (overtorque) or drops below (undertorque) this level, and remains there for at least the Torque Detection Time (L6-03), then the Torque Detection Function will change the state of any digital output configured for Torque Detection (H2-0x = "B: Torque Detection 1 N.O.", or "17: Torque Detection 1 N.C.").

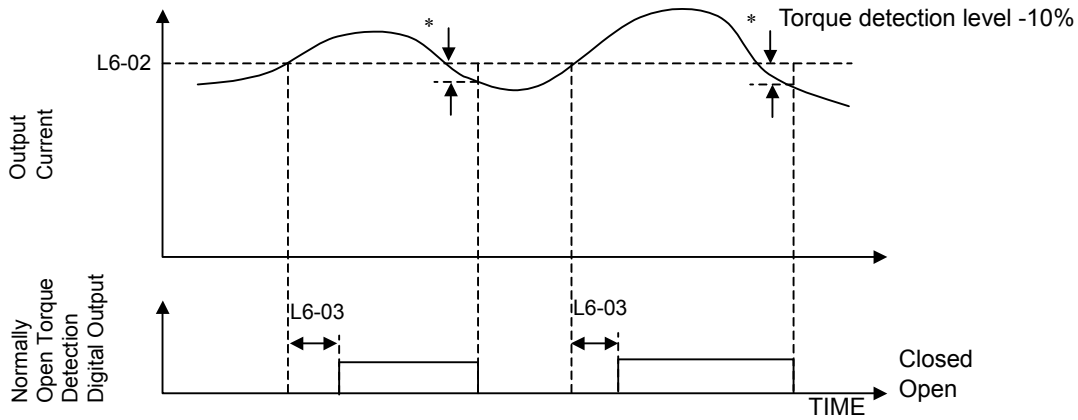

* When the output current drops below the Torque Detection Level by approximately 10% of the Drive's rated output current the digital output is reset.

Fig. 92 Over Torque Detection

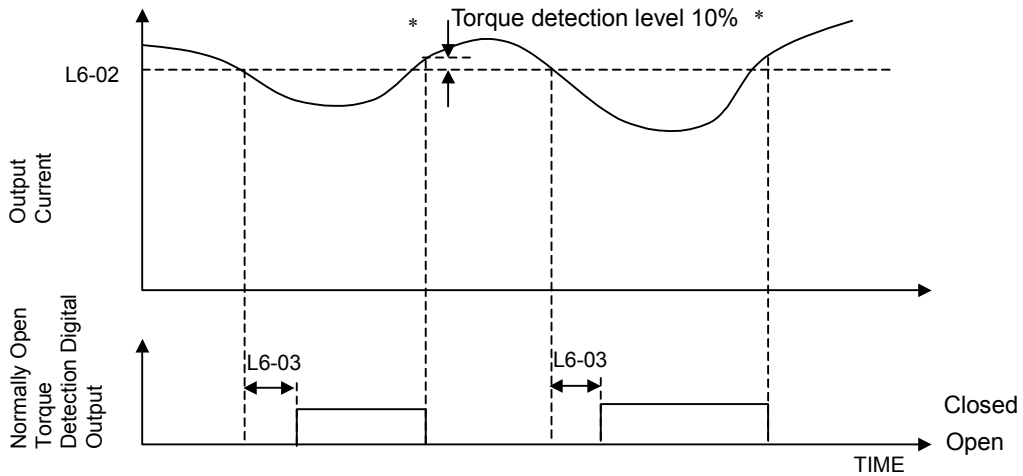

* When the output current rises above the Torque Detection Level by approximately 10% of the Drive's rated output current the digital output is reset.

Fig 93 Under Torque Detection

■ L6-04 Torque Detection Selection 2

Setting	Description
0	Disabled (<i>factory default</i>)
1	OL3 at Speed Agree - Alarm
2	OL3 at Run - Alarm
3	OL3 at Speed Agree - Fault
4	OL3 at Run - Fault
5	UL3 at Speed Agree - Alarm
6	UL3 at Run - Alarm
7	UL3 at Speed Agree - Fault
8	UL3 at Run - Fault

■ L6-05 Torque Detection Level 2

Setting Range: 0 to 300% of Drive rated output current
Factory Default: 150% of Drive rated output current

■ L6-06 Torque Detection Time 2

Setting Range: 0.0 to 10.0 Seconds
Factory Default: 10.0 Seconds

Torque detection 2 functions the same way as torque detection selection 1. The multi-function outputs associated with torque detection 2 are torque detection 2 N.O. and torque detection 2 N.C. (H2-0x = 18 and 19, respectively). See parameter description above for details.

◆ L7 Torque Limit

■ L7-01 Forward Torque Limit

■ L7-02 Reverse Torque Limit

■ L7-03 Forward Regenerative Torque Limit

■ L7-04 Reverse Regenerative Torque Limit

Setting Range: 0 to 300 %
Factory Default: 200%

The torque limit function limits the amount of motor torque in all four quadrants of vector control operation:

- Forward Motoring
- Reverse Motoring
- Forward Regenerating
- Reverse Regenerating

Torque limit is activated in both the speed and torque control when operating in open loop vector or flux vector control methods (A1-02 = 2 or 3). If the multi-function analog input is programmed for “10: Forward Torque Limit”, “11: Reverse Torque Limit”, “12: Regen Torque Limit”, or “15: FWD/REV Torque Limit”, the Drive uses the lower value of either L7-0x or analog input torque limit.

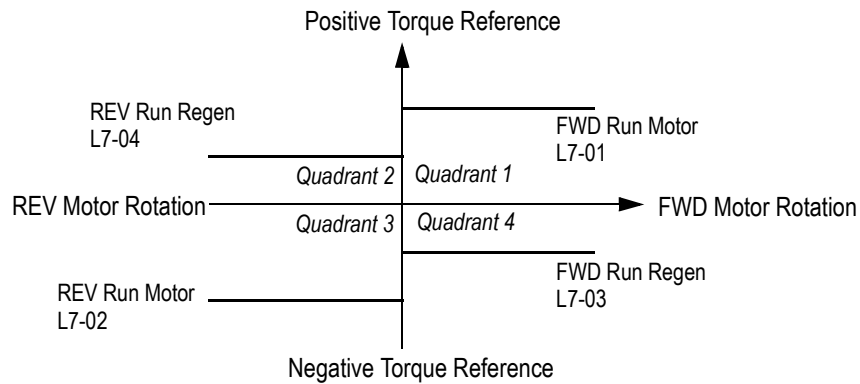

Fig. 94 Torque Limit - 4 Quadrant Operation

The following block diagram shows the relationship between torque limit using parameter settings and torque limit using multi-function analog inputs.

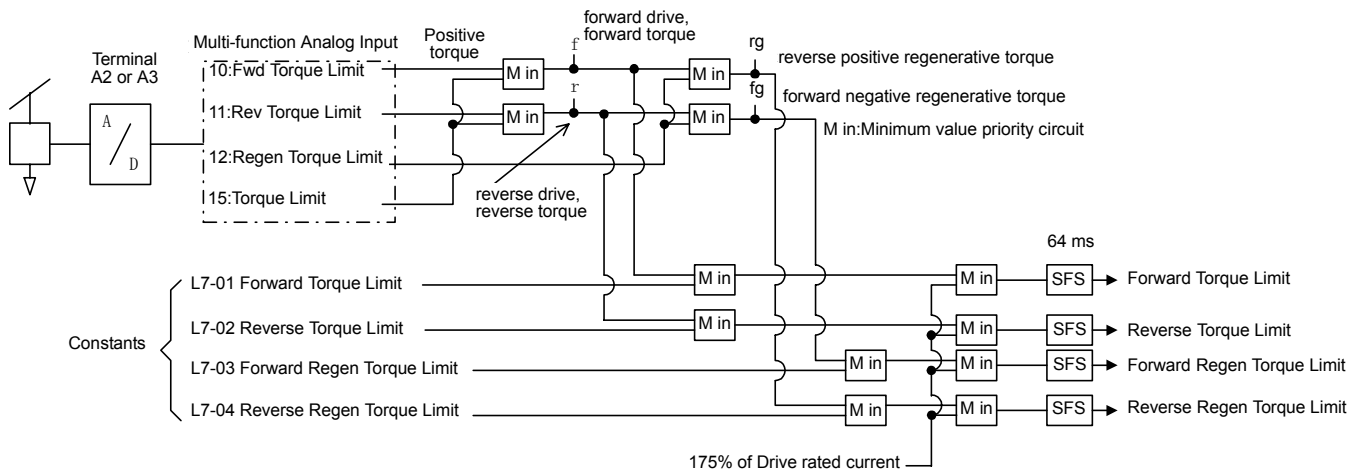

Fig. 95 Torque Limit Block Diagram

◆ L8 Hardware Protection

■ L8-01 Internal Dynamic Braking Resistor Protection Selection

Setting	Description
0	Not Provided (<i>factory default</i>)
1	Provided

This parameter selects the dynamic braking resistor protection only when using the 3% duty cycle heatsink mount Yaskawa braking resistor. This parameter does not enable or disable the general dynamic braking function of the Drive. Do not adjust this parameter when using any other braking resistors.

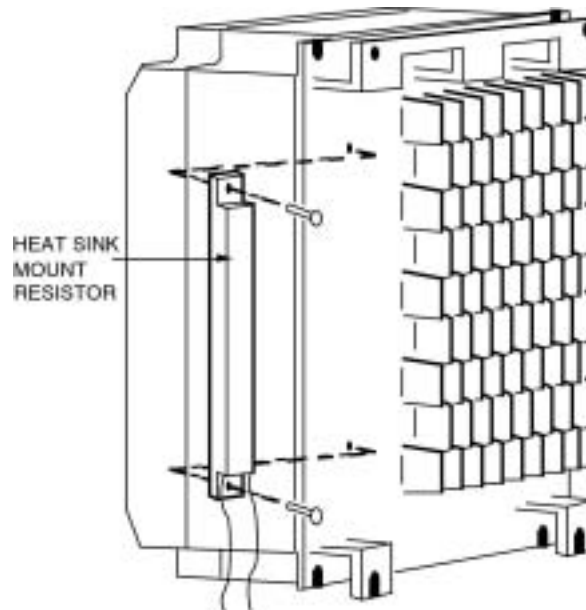

Fig. 96 Heat Sink Mount Resistor

■ L8-02 Overheat Pre-Alarm Level

Setting Range: 50 to 130°C

Factory Default: 95°C

■ L8-03 Overheat Pre-Alarm Operation Selection

Setting	Description
0	Ramp to Stop (Decel Time C1-02)
1	Coast to Stop
2	Fast-Stop (Decel Time C1-09)
3	Alarm Only (<i>factory default</i>)

The Drive is capable of warning the operator of an impending heatsink over-temperature fault via an OH pre-alarm. The level at which the pre-alarm will activate is determined by the setting of parameter L8-02. Measurement of the heatsink temperature

is done with several strategically mounted thermistors. If any of the heatsink thermistors measure a temperature in excess of the setting of L8-02, the Drive will fault (OH2) and either ramp to stop using the active deceleration rate (L8-03= “0: Ramp to Stop”), coast to stop (L8-03= “1: Coast to Stop”), ramp to stop using the C1-09 fast stop deceleration rate (L8-03= “2: Fast-Stop”), alarm (OH) and continue running (L8-03 = “3: Alarm Only”), alarm (OH) and continue running but at a reduced speed (L8-03= “4: Alarm & Reduce”). If the digital output is configured for OH Prealarm (H2-01= “20: OH PreAlarm”), it will close whenever the heatsink temperature is greater than the L8-02 level no matter what the setting is of L8-03.

■ L8-05 Input Phase Loss Protection

Setting	Description
0	Disabled
1	Enabled (<i>factory default</i>)

The input phase loss detection circuit monitors the DC bus current ripple and activates when the one of the input phases are lost. The detection circuit calculates the maximum and minimum values of the DC bus voltage in one second intervals, and compares the difference (ΔV) between these values with an internal detection level. If ΔV reaches or exceeds the detection level, then after 0.5 second, input phase loss is detected; a PF fault occurs, and the motor coasts to stop.

Input phase loss detection is disabled in the following cases:

- A Stop command is input.
- Magnetic Contactor (MC) shuts OFF.
- CPU A/D converter fault (CPF5).
- During deceleration.
- Output current $\leq 30\%$ of Inverter rated current.

■ L8-07 Output Phase Loss Protection

Setting	Description
0	Disabled
1	1-Phase Loss Detection
1	2/3-Phase Loss Detection (<i>factory default</i>)

The output phase loss detection circuit monitors the DCCT and activates when one or more of the output phases are lost. The detection circuit calculates the RMS current value (I_{RMS}) for each of the phases and compares it with an internal output detection level. If I_{RMS} decreases to or below the detection level for 10 seconds, an output phase loss (LF) fault occurs, and the motor coasts to stop.

■ L8-09 Output Ground Fault Detection Selection

Setting	Description
0	Disabled
1	Enabled (<i>factory default</i>)

The Drive has a ground fault detection circuit that activates when the current to ground exceeds 50% of the Drive’s rated output current. The current to ground is determined by comparing the measured current on each of the output phases. If the current to ground is determined to be above 50% of the Drive’s rated output current the digital operator will display a GF and the Drive will coast to stop.

■ **L8-10 Heatsink Cooling Fan Operation Selection**

Setting	Description
0	Fan On-Run Mode (<i>factory default</i>)
1	Fan Always On

■ **L8-11 Heatsink Cooling Fan Operation Delay Time**

Setting Range: 0 to 300 Seconds

Factory Default: 300 Seconds

Parameters L8-10 and L8-11 allow the Drive programmer to customize the heatsink cooling fan operation. Parameter L8-10 determines whether the cooling fans are always ON whenever the Drive is powered (L8-10= “1: Fan Always On”) or if the cooling fans are only ON when the Drive is in a Run condition (L8-10= “0: Fan On-Run Mode”).

Parameter L8-11 is a delayed OFF for the cooling fan if L8-10= “0: Fan On-Run Mode”. When the cooling fans are set to turn OFF when the Run command is removed, parameter L8-11 will cause the fans to continue cooling the Drive for the amount of time programmed into L8-11 after the Run command is actually removed. The Drive can be programmed to allow the cooling fan to run for up to 5 minutes (factory default) after the run command is removed.

Both parameters are intended to extend fan life while still providing sufficient cooling for proper Drive operation.

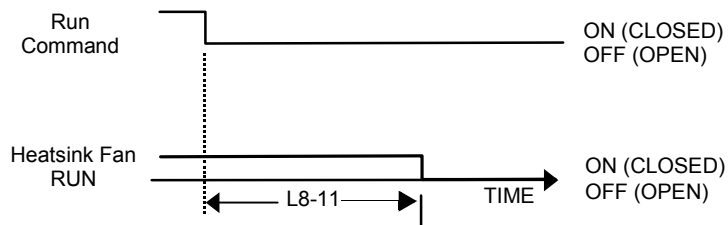

Fig. 97 Heatsink Cooling Fan Operation Timing Diagram

■ **L8-12 Ambient Temperature Setting**

Setting Range: 113 to 140°F (45 to 60°C)

Factory Default: 113°F (45°C)

Set parameter L8-12 to the temperature °F (°C) of the area in which the Drive is mounted. If L8-12 exceeds the actual rated ambient temperature of the Drive 113°F (45°C), the OL2 fault level will be de-rated as shown in the figure below. This will allow the user to trade-off lighter drive loading for operation in a higher ambient temperature.

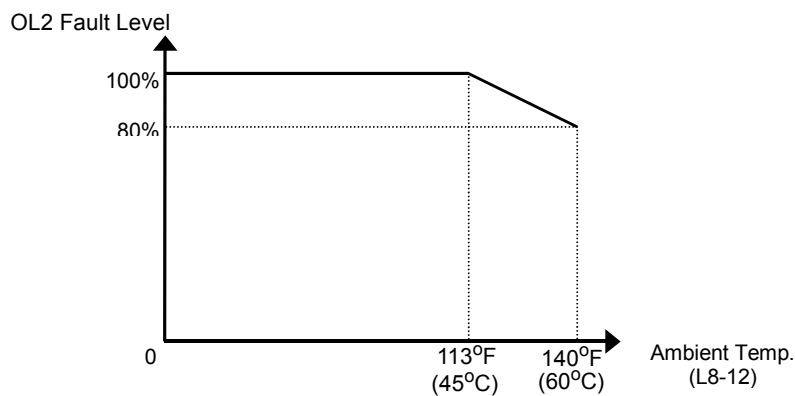

Fig. 98 Ambient Temperature Derating Curve

■ L8-15 OL2 Characteristic Selection at Low Speeds

Setting	Description
0	Disabled
1	Enabled (L8-18 is active) (<i>factory default</i>)

At very low speeds (6 Hz and below) and very high current levels it can be possible to damage output transistors. Therefore the factory default setting of L8-15 is to shorten the time before an OL2 fault will occur during low speed/high load situations (L8-15= “1: Enabled”).

■ L8-18 Soft CLA Selection

Setting	Description
0	Disabled
1	Enabled (<i>factory default</i>)

The Soft CLA (software current limit level) is a Drive protection function that will limit the Drive’s output current. The Drive limits the output current by reducing the output frequency whenever the current exceeds 110% of the inverter rated current. If the current level drops below the Soft CLA level, then normal operation will continue.

If the software current limit is disabled (L8-18= “0: Disabled”), the Drive may trip on an OC fault if the load is prohibitively large or the acceleration is too short. For proper Drive protection and operation leave the Soft CLA function enabled.

◆ n1 Hunting Prevention

■ n1-01 Hunting Prevention Selection

Setting	Description
0	Disabled
1	Enabled (<i>factory default</i>)

■ n1-02 Hunting Prevention Gain Setting

Setting Range: 0.00 to 2.50
Factory Default: 1.00

Sometimes when the Drive is lightly loaded and the carrier frequency is high, the Drive’s output current may vary, or hunt. This varying current can cause the motor to vibrate. The Drive’s Hunting Prevention function can stabilize the motor’s magnetizing current by adjusting the output voltage (n1-01= “1: Enabled”). The Hunting Prevention function can eliminate the vibration but at the cost of Drive response.

Parameter n1-02 can adjust the gain of the Hunting Prevention function if it is enabled by n1-01. Normally there is no need to adjust n1-02 from the factory default setting. Make adjustments in the following cases:

- If vibration occurs with a light load, increase the setting of n1-02.
- If the motor stalls, reduce the setting of n1-02.

An overly large Hunting Prevention Gain (n1-02) may cause the motor to stall.

◆ n2 AFR Tuning

■ n2-01 Speed Feedback Detection Control (AFR) Gain

Setting Range: 0.00 to 2.50
Factory Default: 1.00

Sets the internal speed feedback detection control gain in the AFR. Normally there is no need to adjust n2-01 from the factory default setting. Make adjustments in the following cases:

- If hunting occurs, increase the set value.
- If response is low, decrease the set value.

Adjust the setting by 0.05 units at a time while checking the response.

■ n2-02 Speed Feedback Detection Control (AFR) Time Constant

Setting Range: 0.00 to 2.50
Factory Default: 1.00

Sets the time constant to control the rate of change in the speed feedback detection control.

■ n2-03 Speed Feedback Detection Control (AFR) Time Constant 2

Setting Range: 0.00 to 2.50
Factory Default: 1.00

Sets the time constant to control the amount of change in the speed at low speed.

◆ n3 High Slip Braking

High slip braking (HSB) is a method of decreasing the stopping time of a load without using dynamic braking. The regenerated energy of the decelerating load is dissipated in the motor windings through increased motor slipping. Because of the increased temperature of the motor windings, there is a limitation on the occurrence of HSB usage (~5% duty cycle). The stopping time using HSB is approximately 50% of what can be done with the standard braking methods. HSB can be activated by closing a digital input configured as a High Slip Braking input (H1-0x=68). The HSB digital input has priority over an active Run input and will be implemented immediately. HSB is only applied to stopping the motor and load and cannot be used for changing speeds. HSB can only be activated when the output frequency is greater than 6 Hz. When a HSB command is given it is not possible to restart the Drive until the motor is stopped and the Run command is cycled.

IMPORTANT

It is very important that Auto-tuning is performed before High Slip Braking is attempted. The Drive should be Auto-tuned again if the motor or cable length is changed since the last Auto-tuning.

■ n3-01 High-Slip Braking Deceleration Frequency Width

Setting Range: 1 to 20% of maximum frequency
Factory Default: 5% of maximum frequency

Parameter n3-01 sets the amount of frequency reduction that will be applied in order to create the increase motor slip condition and lower the DC Bus voltage. Normally this parameter will not need to be adjusted from the factory default. If the OV fault occurs during HSB increase n3-01 in small increments (~2% per adjustment). n3-01 is set as a percentage of the maximum frequency (E1-04).

■ n3-02 High-Slip Braking Current Limit

Setting Range: 100 to 200% of Drive rated output current
 Factory Default: 150% of Drive rated output current

Parameter n3-02 sets the maximum current to be output during an HSB stop. The higher n3-02 is set the shorter the motor stopping time will be but the greater the motor winding heating will be. Increasing the setting of n3-02 should only be done in small increments. Parameter n3-02 is set as a percentage of motor rated current (E2-01).

■ n3-03 High-Slip Braking Dwell Time at Stop

Setting Range: 0.0 to 10.0 Seconds
 Factory Default: 1.0 Seconds

At the end of a HSB action the Drive will hold the frequency reference at the minimum frequency (E1-09) for a period of time configured by parameter n3-03. If n3-03 is set too short there may be residual motion of the motor shaft after the HSB braking has completed and the Drive output is shut off. The residual motion can be caused by machine/load inertia.

■ n3-04 High-Slip Braking Overload Time

Setting Range: 30 to 1200 Seconds
 Factory Default: 40 Seconds

The OL7 (HSB Overload) fault will occur if the Drive frequency does not change within the time specified by the n3-04 parameter. The non-changing frequency can be caused by a load with excessive inertia or a motor that is being overhauled by the load. A good test for the excessive load inertia is whether the Drive can stop the load normally (w/o a braking resistor but not with HSB) in 180 seconds or less.

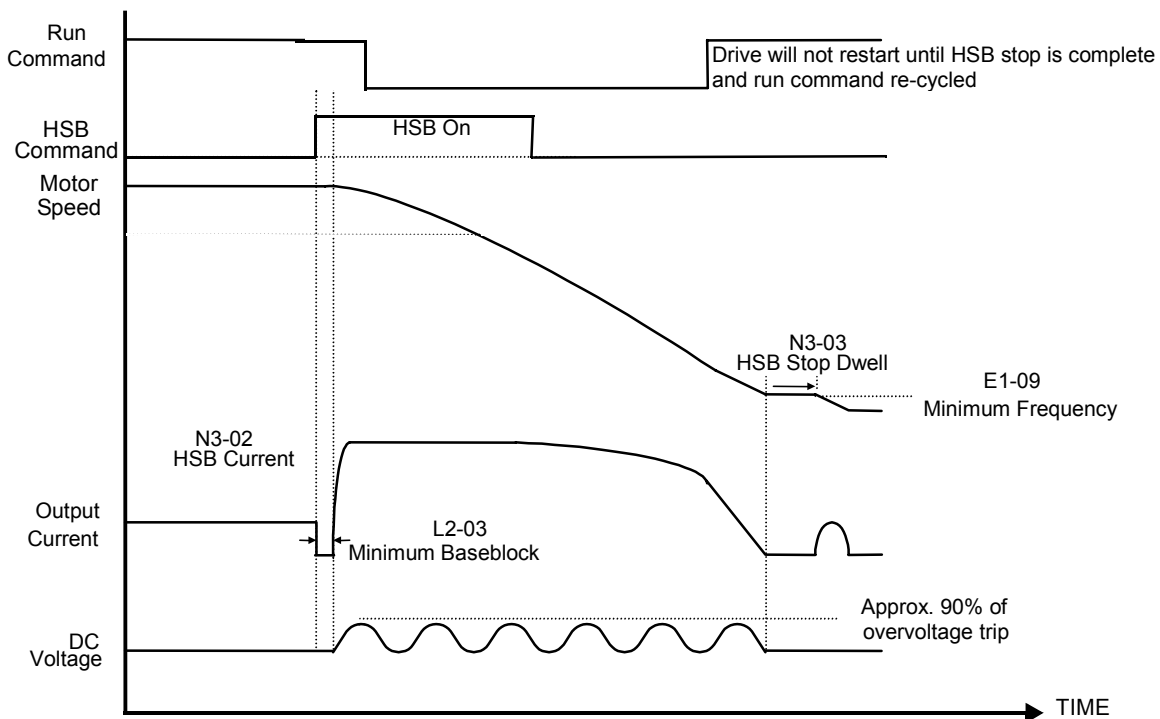

Fig. 99 High Slip Braking Timing Diagram
 Programming 136

◆ o1 Monitor Configuration

■ o1-01 User Monitor Selection

Setting Range: 4 to 45

Factory Default: 6

Setting	Description
4	Control Method
5	Motor Speed
6	Output Voltage (<i>factory default</i>)
7	DC Bus Voltage
8	Output Power
9	Torque Reference
10	Input Terminal Status
11	Output Terminal Status
12	Drive Operation Status
13	Cumulative Operation Time
14	Software Number
15	Terminal A1 Level
16	Terminal A2 Level
17	Terminal A3 Level
18	Motor Secondary Current (I_q)
19	Motor Excitation Current (I_d)
20	Output Frequency After Soft Start
21	ASR Input
22	ASR Output
24	PID Feedback Value
25	DI-16H2 Input Status
26	Output Voltage Reference (V_q)
27	Output Voltage Reference (V_d)
28	CPU Number
29	Kilowatt-Hours Low 4 Digits
30	Kilowatt-Hours High 5 Digits
32	ACR Output of q Axis
33	ACR Output of q Axis
34	First Parameter Causing an OPE
35	Zero Servo Pulse Count
36	PID Input
37	PID Output
38	PID Setpoint
39	Memobus Communication Error Code
40	Heatsink Cooling Fan Operation Time
44	ASR Output Without Filter
45	Feed Forward Control Output

■ o1-02 Power-On Monitor

Setting	Description
1	Frequency Reference (<i>factory default</i>)
2	Output Frequency
3	Output Current
4	User Monitor (set by o1-01)

When the Drive is powered up, three monitors are displayed on the digital operator. The first and largest monitor is the “Power-On” monitor. The factory default “Power-On monitor” is frequency reference (U1-01). Below the frequency reference monitor are the next two sequential monitors, Output Frequency (U1-02) and Output Current (U1-03). Pressing the INCREASE key once scrolls the monitors to show the User Monitor as selected by o1-01. The factory default for o1-01 is the Output Voltage monitor (U1-06).

The active monitor displayed when the Drive is powered on can be changed to either be U1-01 (frequency reference), U1-02 (Output Frequency), U1-03 (Output Current), or the User Monitor. Whichever monitor is selected as the Power-On top monitor, the two monitors displayed below it are the next two sequential monitors. See example below.

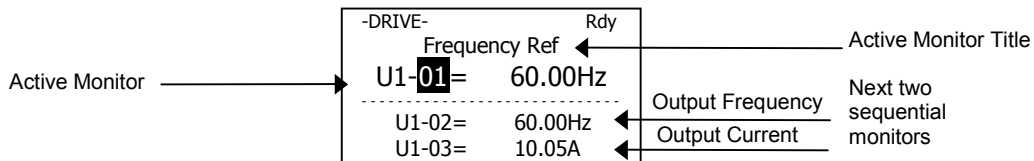

For example, if the Drive needs to display the Elapsed Timer as the Power-On monitor, then o1-01 must be set to “13” and o1-02 must be set to “4”. The next time Drive power is cycled, the digital operator displays U1-13 (Elapsed Time), U1-14 (Flash ID), and U1-15 (Term AI Level).

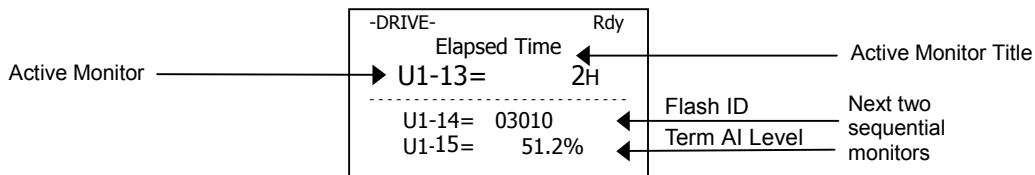

■ o1-03 Digital Operator Display Scaling

Setting	Description
0	Hz (<i>factory default</i>)
1	%
2 - 39	RPM (Enter the # of Motor Poles)
40 - 39999	User Display

Parameter o1-03 allows the programmer to change the units in which the speed monitors and some speed parameters are displayed. The o1-03 parameter will change the units of the following:

- U1-01 (Frequency Reference Monitor)
- U1-02 (Output Frequency Monitor)
- U1-20 (Output Frequency after Soft Start)
- d1-01 through d1-17 (Preset Frequency References and Jog Reference)

The table below details how the setting of o1-03 will affect the way the listed monitors and parameters will be displayed.

If o1-03 is:	The frequency format is
0	0.01 Hz
1	0.00%
2 through 39 (enter the # of motor poles)	0 RPM
40 through 39999	Engineering Units

The factory default setting (o1-03="0") sets the Drive up to display the affected monitors and parameters in terms of hertz (Hz).

If the speeds seem more natural in terms of percentage of maximum, set o1-03= "1". If the speeds are easier to work with when displaying the equivalent synchronous motor RPM, set o1-03= [the number of motor poles]. If another engineered unit, such as fpm or gpm, is desired, set o1-03= xxxx where

 X X X X X
 Digit 5 Digit 4 Digit 3 Digit 2 Digit 1

Digits 1 through 4 set the desired number to be displayed at 100% speed.
 Digit 5 determines the number of decimal places in the displayed number.

If Digit 5 = 0 number format is XXXX
 If Digit 5 = 1 number format is XXX.X
 If Digit 5 = 2 number format is XX.XX
 If Digit 5 = 3 number format is X.XXX

For example:

If o1-03= 10425, then at full speed the digital operator will display "42.5". Configuring parameter o1-03 for displaying in terms of an engineering unit is only appropriate if the actual display units have a linear relationship with the actual output speed.

■ o1-04 Display Units

Setting	Description
0	Hertz (<i>factory default</i>)
1	RPM

This parameter sets the setting units related to V/f pattern frequency related parameters (E1-04, -06, -09, -11).

■ o1-05 LCD Contrast Adjustment

Setting Range: 0 to 5

Factory Default: 3

The contrast setting of the LCD display of the digital operator can be adjusted by the setting of parameter o1-05. The higher the number programmed into o1-05, the darker the background will become. Set o1-05 to the value that makes the LCD the easiest to view at the normal viewing distance and angle.

◆ o2 Key Selections

■ o2-01 Local/Remote Key Selections

Setting	Description
0	Disabled
1	Enabled (<i>factory default</i>)

Parameter o2-01 determines whether the Local/Remote switch on the digital operator will be enabled and will switch between keypad operation and the sources specified by the b1-01 and b1-02 parameters when the Drive is stopped.

■ o2-02 STOP Key Function Selection

Setting	Description
0	Disabled
1	Enabled (<i>factory default</i>)

The factory default setting of the STOP Key Function During Auto Run parameter (o2-02= “1: Enabled”) enables the STOP key on the digital operator even if b1-02 specifies the Run command source for the Remote mode as not coming from the digital operator. In effect the STOP key becomes an alternative Stop input. Once the Drive has been stopped by the STOP key it can be restarted either by cycling the external Run command. If o2-02= “0: Disabled”, pressing the STOP key while in the Remote mode will have no effect.

■ o2-03 User Parameter Default Value

Setting	Description
0	No Change
1	Set Defaults
2	Clear All

The Drive gives the option of configuring any and all of the programming parameters and then saving the parameters as “User Initialization Values”. After configuring the Drive, set parameter o2-03= “1: Set Defaults”, to save the parameters to a User Initialization memory location. Once this has been done, the “Initialize Parameters” parameter (A1-03) will offer the choice of “1110:User Initialize”. Choosing A1-03= “1110: User Initialized”, will reset all modified parameters back to what they were the last time they were saved using o2-03.

The choice of setting A1-03= “1110: User Initialized”, is unavailable until first setting the User Initialization parameters using o2-03. Once a User Initialization is set (saved), it can be cleared by setting o2-03= “2: Clear All”. After clearing the User Initialization parameters, the choice of “1110: User Initialize” is no longer available in A1-03.

■ **o2-04 Drive / kVA Selection**

Setting Range: 0 to FF

Factory Default: Model Dependent

Parameter o2-04 matches the control board to the Drive hardware. Proper setting of o2-04 is important so that the control board can provide proper protection for the Drive hardware. This parameter is configured at the factory and does not normally require adjustment in the field. It is available primarily to accommodate control board replacement in the event of damage.

Table 25 o2-04 Selection			
208-230/240Vac		480Vac	
Model Number F7U	Proper o2-04 Setting	Model Number F7U	Proper o2-04 Setting
20P4	0	40P4	20
20P7	1	40P7	21
21P5	2	41P5	22
22P2	3	42P2	23
23P7	4	43P7	24
27P5	6	45P5	26
2011	7	47P5	27
2015	8	4011	28
2018	9	4015	29
2022	A	4018	2A
2030	B	4022	2B
2037	C	4030	2C
2045	D	4037	2D
2055	E	4045	2E
2075	F	4055	2F
2090	10	4075	30
2110	11	4090	31
		4110	32
		4132	33
		4160	34
		4185	35
		4220	36
		4300	37

The factory defaults of the following parameters may be changed when the setting of o2-04 is changed:

- b8-04 (Energy Saving Coefficient Value)
- C6-02 (Carrier Frequency Selection)
- E2-01 (Motor Rated Current)
- E2-03 (Motor No-Load Current)
- E2-05 (Motor Line-to-Line Resistance)
- L2-02 (MPL Ride-Thru Time)
- L2-03 (MPL Minimum Base Block Time)
- L2-04 (MPL Voltage Recovery Ramp Time)
- L8-02 (Overheat Pre-Alarm Level)
- L8-06 (Input Phase Loss Detection Level)

■ o2-05 Frequency Reference Setting Method Selection

Setting	Description
0	Disabled
1	Enabled (<i>factory default</i>)

The factory default setting of the Frequency Reference Setting Method parameter (o2-05= “1: Enabled”) dictates that when setting a frequency reference via the digital operator (Local mode), it is not necessary to press the DATA/ENTER key before the Drive will begin to accelerate or decelerate to the new set speed. This is referred to as MOP (Motor Operated Potentiometer) type functionality. When o2-05= “1: Enabled”, the frequency reference is stored to memory 5 seconds after the INCREASE or DECREASE keys are released.

When o2-05= “0: Disabled”, the digital operator INCREASE and DECREASE keys will change the frequency reference but the Drive will not accelerate or decelerate to the new frequency reference until the DATA/ENTER key is pressed. In order to change the frequency reference in the HAND mode, U1-01 must be the top monitor and then the ENTER key must be pressed in order to access the frequency reference function. This is not to be confused with pressing the ENTER key in order to achieve a change in speed using the INCREASE and DECREASE keys, which is the subject of parameter o2-05.

■ o2-06 Operation Selection when Digital Operator is Disconnected

Setting	Description
0	Disabled
1	Enabled (<i>factory default</i>)

Leaving o2-06 enabled will cause the Drive to fault, when the digital operator is removed, even if it’s not outputting to the motor. The reset key on the digital operator will need to be pressed after reconnecting the digital operator to reset the fault and continue normal operation.

If o2-06 = “0: Disabled” then the Drive will not fault if the digital operator is disconnected, but the Drive will discontinue motor operation. If full Drive operation is required while the digital operator is removed set o2-06 = “0: Disabled”.

■ o2-07 Cumulative Operating Time Setting

Setting Range: 0 to 65535 Hours

Factory Default: 0 Hours

■ o2-08 Cumulative Operation Time Selection

Setting	Description
0	Power-On Time
1	Running Time (<i>factory default</i>)

The Drive features an Elapsed Timer monitor that records in units of hours. The Elapsed Timer monitor is U1-13. Parameter o2-08 programs this function to either accumulate elapsed hours based on time the Drive is powered (o2-08= “0: Power-On Time”) or time the Drive is running (o2-08= “1: Running Time”). The Drive is considered “running” any time there is an active run command or when the Drive is outputting voltage (i.e. including during deceleration).

-DRIVE-	Rdy
Elapsed Time	
U1-13= 0H	

U1-14= 03010	
U1-15= 34.1%	

Parameter o2-07 allows manual adjustment of the Elapsed Timer, primarily to accommodate maintenance or control board replacement in the event of damage. To reset the Elapsed Timer back to zero, set o2-07= 0.

■ o2-09 Initialization Specification Selection

Setting	Description
1	American Spec (<i>factory default</i>)
2	European Spec

Different regions of the world have different electrical standards. The Drive’s factory defaults may be perfect for one region and improper for another. The o2-09 parameter allows the programmer to change en mass most parameter defaults to reflect best the region where the Drive will be installed and operated.

After a change has been made in parameter o2-09, the Drive should be re-initialized by parameter A1-03 to complete the change to a new specification.

The parameters that are changed by o2-09 are:

Parameter Number	Parameter Description	European Specifications (o2-09=2)	American Specifications (o2-09=1)
b1-04	Reverse Operation Sel	0 (Reverse Enabled)	1 (Reverse Disabled)
b2-04	DCInj Time @ Stop	0.5sec	0.0sec
b5-02	PID(D) P gain	1	2
b5-03	PID(D) I time	1.0sec	5.0sec
C1-01	Accel time 1	10.0sec	30.0sec

Parameter Number	Parameter Description	European Specifications (o2-09=2)	American Specifications (o2-09=1)
C1-02	Decel time 1	10.0sec	30.0sec
C1-03	Accel time 2	10.0sec	30.0sec
C1-04	Decel time 2	10.0sec	30.0sec
C1-09	Fast stop	10.0sec	30.0sec
E1-01	Input voltage	200/400VAC	240/480VAC
E1-04	Max. Frequency	50.0Hz	60.0Hz
E1-05	Max. Voltage	200/400VAC	240/480VAC
E1-06	Base Frequency	50.0Hz	60.0Hz
H2-02	M3-M4 function	1 (Zero speed)	A (Run from operator)
H3-09	A2 function	0 (Freq. Bias)	2 (Aux. Ref.)
L2-01	Momentary UV detection	0 (Disabled: UV1)	2 (As long as possible)
L5-03	Fault retry cont. time	10.0sec	180.0sec
L6-01	Torque detection Sel. 1	6 (UL1 warning)	0 (Disabled)
o2-05	Freq. Ref setting method	0 (with ENTER key)	1 (without ENTER key)

■ o2-10 Cumulative Cooling Fan Operation Time Setting

Setting Range: 0 to 65535 Hours

Factory Default: 0 Hours

The elapsed time of heatsink cooling fan operation is tracked by the U1-40 monitor. Much like the o2-07 parameter can be used to adjust or reset the Drive operation elapsed timer, parameter o2-10 can be used to adjust the time displayed by the U1-40 monitor in the event of fan replacement.

-DRIVE-	Rdy
FAN Elapsed Time	
U1-40=	152H

U1-51=	52.33%
U1-52=	57.60%

■ o2-12 Fault Trace / Fault History Clear Function

Setting	Description
0	Disabled (No Effect) (<i>factory default</i>)
1	Enabled

The operator can clear the Fault Trace (U2) and Fault History logs by setting o2-12= “1: Enabled”. Clearing the Fault Trace and Fault History logs erases all the information.

■ o2-14 kWh User Monitor Initialization

Setting	Description
0	Disabled (No Change) (<i>factory default</i>)
1	Clear All

The kWh monitors (U1-29 and U1-30) track the power usage of the Drive and are not reset by powering down the Drive. To reset the monitors back to zero, set o2-14= “1: Clear all”.

◆ o3 Digital Operator Copy Function

■ o3-01 Copy Function Selection

Setting	Description
0	COPY SELECT (<i>factory default</i>)
1	INV→OP READ
2	OP→INV WRITE
3	OP↔INV VERIFY

■ o3-02 Read Allowed Selection

Setting	Description
0	Disabled (<i>factory default</i>)
1	Enabled

The digital operator has parameter COPY capabilities via built in non-volatile memory. The digital operator can READ all of the parameters in the Drive and store them for later WRITE back to the Drive or into a Drive with the same product code and software number. In order to read the parameter values and store them in the digital operator, select o3-02= “1: Enabled”. If you attempt to READ the data, which overwrites any previously stored data, without first setting o3-02= “1: Enabled”, you will get the following error:

-ADV- PRE READ IMPOSSIBLE

After setting o3-02= “1: Enabled”, it is possible to store parameter values in the digital operator by setting o3-01=1 (INV→OP READ).

A successful READ of the parameter values will display:

-ADV- READ READ COMPLETE

An error may occur while saving the parameter values to the digital operator’s memory. If an error is displayed, press any key to cancel the error display and return to parameter o3-01. Error displays and their meanings are covered in Chapter 6: Diagnostics and Troubleshooting of the F7 Users Manual (TM.F7.01). To COPY parameter values into a Drive, set o3-01= “2: OP->INV WRITE”. During the writing of the parameter values into the Drive the digital operator will display:

-ADV-
COPY
OP→INV COPYING

A successful COPY of the parameter values will display:

-ADV-
COPY
COPY COMPLETE

An error may occur while writing the parameter values to the Drive. If an error is displayed, press any key to cancel the error display and return to parameter o3-01. Error displays and their meanings are covered in Chapter 6: Diagnostics and Troubleshooting of the F7 Users Manual (TM.F7.01).

It is possible to compare the parameter values stored in the digital operator with the parameter values currently in the Drive by using the VERIFY function. This VERIFY function should not be confused with the “-VERIFY-“that is displayed on the digital operator when viewing the “Modified Constants” menu. To VERIFY the parameter values in the Drive as compared with those stored in the digital operator, set o3-01= “3: OP<-->INV VERIFY”. During the comparing of the parameter values into the Drive the digital operator will display:

-ADV-
VERIFY
DATA VERIFYING

A successful VERIFY of the parameter values will display:

-ADV-
VERIFY
VERIFY COMPLETE

If all the parameter values stored in the digital operator do not match those programmed in the Drive, the digital operator displays the following:

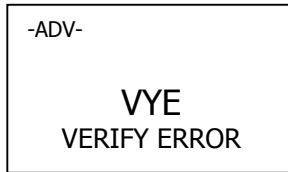

The digital operator will not display which parameters did not match, only that the verification found discrepancies in some parameter values.

NOTE: In order to properly use the COPY or VERIFY functions, the following Drive specifications must be identical between the Drive that the parameters were read from and the Drive that the parameters are to be written to:

- Model Number (e.g. CIMR-F7U2015)
- Software Number (e.g. 03011 as known as FLASH ID)

Yaskawa offers DriveWizard™ software that can also READ, COPY, and VERIFY Drive parameter values. DriveWizard™ lists all discrepancies between the Drive and a pre-saved parameter file when verifying is performed.

To use DriveWizard first select o2-15= “0: Disabled” and select o2-06= “0: Disabled” then remove the digital operator/keypad and attach the DriveWizard cable in its place.

◆ T1 Auto-Tuning

Auto-tuning the Drive is recommended to achieve optimum performance. The T1 parameters are found under the Auto-Tuning menu. Step-by-step instructions on auto-tuning is covered in Chapter 4: Start Up of the F7 Users Manual (TM.F7.01).

■ T1-00 Motor Selection 1 / 2

Setting	Description
1	1st Motor - E1 to E2 Parameters (<i>factory default</i>)
2	2nd Motor - E3 to E4 Parameters

This auto-tuning parameter selects which set of motor parameters to used and set during auto-tuning. If motor 2 selection (H1-0x = 16) is not selected, this parameter will not be displayed.

■ T1-01 Auto-Tuning Mode Selection

Setting	Description
0	Rotational Auto-Tuning (<i>factory default</i>)
1	Stationary Auto-Tuning
2	Terminal Resistance Only

The Drive has the capability to perform three kinds of auto-tuning.

Rotational auto-tuning with the load uncoupled from the motor is strongly recommended whenever possible. Stationary auto-tuning is used whenever it is not possible to disconnect the motor from the load. Rotational and stationary auto-tuning can be selected only when in open loop vector or flux vector control modes (A1-02 = 2 or 3). If terminal resistance auto-tuning is selected, only parameters T1-02 and T1-04 need to be set. Terminal Resistance auto-tuning can be selected in all control modes (A1-02 = 0, 1, 2, or 3).

■ T1-02 Motor Rated Power

Setting Range: 0.00 to 650.00 kW
Factory Default: Model Dependent

Set the rated power in kilowatts (kW) of the motor attached to the Drive. If the motor nameplate lists the rated power in terms of horsepower (HP), use the following formula to convert to kW before setting the value of T1-02:

$$\text{kW} = \text{HP} \times 0.746$$

■ T1-03 Motor Rated Voltage

Setting Range: 0.0 to 255.0 Vac (240V Class), 0.0 to 510.0 (480V Class)
Factory Default: 240 Vac (240V Class), 460Vac (480V Class)

Set the motor rated voltage.

■ T1-04 Motor Rated Current

Setting Range: Model Dependent
Factory Default: Model Dependent

Set the motor rated current (FLA) as stamped on the motor's nameplate.

■ T1-05 Motor Base Frequency

Setting Range: 0.0 to 400.0 Hz
Factory Default: 60.0 Hz

Set the motor base frequency (in Hz) as stamped on the motor's nameplate.

■ T1-06 Number of Motor Poles

Setting Range: 2 to 48
Factory Default: 4

Set the number of motor poles as stamped on the motor's nameplate. If this is not found on the nameplate, use the following formula to determine the number of motor poles

$$\text{Number of Motor Poles} = 120 \times \text{Frequency in Hz} / \text{RPM}$$

Example:

An 1800 RPM, 60Hz motor is $(120 \times 60\text{Hz} / 1800\text{RPM} = 4)$ a 4 pole motor.

■ T1-07 Motor Base Speed

Setting Range: 0 to 2400 RPM

Factory Default: 1750 RPM

Set the base speed of the motor in revolutions per minute (RPM).

■ T1-08 Number of PG Pulses

Setting Range: 0 to 60,000 PPR

Factory Default: 1024 PPR

Set the number of pulses per revolution (PPR) for the encoder (pulse generator) being used without any multiplication factor. This parameter is only set in flux vector control method (A1-02 = 3).

After the last T1 auto-tuning parameter is set, press the INCREASE key once to display this:

-ATUNE-	Rdy
Auto-Tuning	

0Hz/ 0.00A	
Tuning Ready ?	
Press RUN key	

If ready, press the RUN key once to start auto-tuning. This process will last for approximately 15 seconds. Once auto-tuning is finished, the digital operator will display this:

-ATUNE-
Tune Successful

0Hz/ 0.00A

To exit the Auto-Tuning menu, press the MENU key once.

NOTE: It is possible to get a "Data Invalid" error if the T1 auto-tuning parameters fall outside the range of what the Drive will accept as reasonable levels for the programmed size of drive (o2-04). If faults are displayed during auto-tuning, check their meanings covered in Chapter 6: Diagnostics and Troubleshooting of the F7 Users Manual (TM.F7.01).

Notes:

Appendix A

Parameters

This appendix lists all the parameter numbers and names, along with a description of each. The abbreviated name as it appears on the Digital Operator display/keypad is shown in bold type.

F7 Parameter List.....	153
F7 Monitor List.....	189
F7 Fault Trace List.....	192
F7 Fault History List	192

Some parameters in the following tables are not available for all Control Methods (A1-02). Use the key below to determine which parameters are available for the selected Control Method.

V/F	V/F w/PG	Open Loop Vector	Flux Vector
Q	Q	A	-

Q: Parameters which can be monitored and set in either Quick Setting or Advanced Programming Menu

A: Parameters which can be monitored and set in only Advanced Programming Menu

-: Parameters which cannot be monitored or set for the selected Control Method.

F7 Parameter List

Table A.1 F7 Parameter List								
Parameter No.	Parameter Name Digital Operator Display	Description	Setting Range	Factory Setting	Control Method			
					V/F	V/F w/ PG	Open Loop Vector	Flux Vector
Initialization								
A1-00 ◆	Language Selection Select Language	Language selection for the Digital Operator. This parameter is not reset to the factory setting by A1-03. 0: English 1: Japanese 2: Deutsch 3: Francais 4: Italiano 5: Espanol 6: Portugues	0 to 6	0	A	A	A	A
A1-01 ◆	Access Level Selection Access Level	Selects which parameters are accessible via the Digital Operator. 0: Operation Only 1: User Level (only available if A2 parameters have been set) 2: Advanced Level	0 to 2	2	A	A	A	A
A1-02	Control Method Selection Control Method	Selects the Control Method of the Drive. 0: V/F control without PG 1: V/F control with PG 2: Open Loop Vector 3: Flux Vector (Closed Loop Vector)	0 to 3	2	Q	Q	Q	Q
A1-03	Initialize Parameters Init Parameters	Used to return all parameters to their factory or user default settings. (Initializes and then returns A1-03 to zero.) 0: No Initialize 1110: User Initialize (The user must first set their own parameter values and then store them using parameter o2-03.) 2220: 2-Wire Initialization 3330: 3-Wire Initialization	0 to 3330	0	A	A	A	A
A1-04	Password 1 Enter Password	When the value set into A1-04 does NOT match the value set into A1-05, parameters A1-01 thru A1-03 and A2-01 thru A2-32 cannot be changed. All other parameters as determined by A1-01 can be changed. Parameter A1-05 can be accessed by pressing the MENU key while holding the RESET key.	0 to 9999	0	A	A	A	A
A1-05	Password 2 Select Password		0 to 9999	0	A	A	A	A
User Parameters								
A2-01	User Parameter 1 User Param 1	Selects the parameters to be available in the User Access Level (A1-01 = 1). These parameters are not related to the User Initialize function.	b1-01 to o3-02	—	A	A	A	A
A2-02	User Parameter 2 User Param 2			—	A	A	A	A
A2-03	User Parameter 3 User Param 3			—	A	A	A	A
A2-04	User Parameter 4 User Param 4			—	A	A	A	A
A2-05	User Parameter 5 User Param 5			—	A	A	A	A
A2-06	User Parameter 6 User Param 6			—	A	A	A	A
A2-07	User Parameter 7 User Param 7			—	A	A	A	A
A2-08	User Parameter 8 User Param 8			—	A	A	A	A
A2-09	User Parameter 9 User Param 9			—	A	A	A	A
◆Denotes that parameter can be changed when the Drive is running.								

Table A.1 F7 Parameter List (Continued)

Parameter No.	Parameter Name Digital Operator Display	Description	Setting Range	Factory Setting	Control Method			
					V/F	V/F w/ PG	Open Loop Vector	Flux Vector
A2-10	User Parameter 10 User Param 10	Selects the parameters to be available in the User Access Level (A1-01 = 1). These parameters are not related to the User Initialize function.	b1-01 to o3-02	—	A	A	A	A
A2-11	User Parameter 11 User Param 11			—	A	A	A	A
A2-12	User Parameter 12 User Param 12			—	A	A	A	A
A2-13	User Parameter 13 User Param 13			—	A	A	A	A
A2-14	User Parameter 14 User Param 14			—	A	A	A	A
A2-15	User Parameter 15 User Param 15			—	A	A	A	A
A2-16	User Parameter 16 User Param 16			—	A	A	A	A
A2-17	User Parameter 17 User Param 17			—	A	A	A	A
A2-18	User Parameter 18 User Param 18			—	A	A	A	A
A2-19	User Parameter 19 User Param 19			—	A	A	A	A
A2-20	User Parameter 20 User Param 20			—	A	A	A	A
A2-21	User Parameter 21 User Param 21			—	A	A	A	A
A2-22	User Parameter 22 User Param 22			—	A	A	A	A
A2-23	User Parameter 23 User Param 23			—	A	A	A	A
A2-24	User Parameter 24 User Param 24			—	A	A	A	A
A2-25	User Parameter 25 User Param 25			—	A	A	A	A
A2-26	User Parameter 26 User Param 26			—	A	A	A	A
A2-27	User Parameter 27 User Param 27			—	A	A	A	A
A2-28	User Parameter 28 User Param 28			—	A	A	A	A
A2-29	User Parameter 29 User Param 29			—	A	A	A	A
A2-30	User Parameter 30 User Param 30			—	A	A	A	A
A2-31	User Parameter 31 User Param 31			—	A	A	A	A
A2-32	User Parameter 32 User Param 32			—	A	A	A	A

◆Denotes that parameter can be changed when the Drive is running.

Table A.1 F7 Parameter List (Continued)

Parameter No.	Parameter Name Digital Operator Display	Description	Setting Range	Factory Setting	Control Method			
					V/F	V/F w/ PG	Open Loop Vector	Flux Vector
Sequence								
b1-01	Frequency Reference Selection Reference Source	Selects the frequency reference input source. 0: Operator - Digital preset speed U1-01 or d1-01 to d1-17. 1: Terminals - Analog input terminal A1 (or terminal A2 based on parameter H3-09). 2: Serial Com - Modbus RS-422/485 terminals R+, R-, S+, and S-. 3: Option PCB - Option board connected on 2CN. 4: Pulse Input (Terminal RP)	0 to 4	1	Q	Q	Q	Q
b1-02	Run Command Selection Run Source	Selects the run command input source. 0: Operator - RUN and STOP keys on Digital Operator. 1: Terminals - Contact closure on terminals S1 or S2. 2: Serial Com - Modbus RS-422/485 terminals R+, R-, S+, and S-. 3: Option PCB - Option board connected on 2CN.	0 to 3	1	Q	Q	Q	Q
b1-03	Stopping Method Selection Stopping Method	Selects the stopping method when the run command is removed. 0: Ramp to Stop 1: Coast to Stop 2: DC Injection to Stop 3: Coast with Timer (A new run command is ignored if received before the timer expires).	0 to 3	0	Q	Q	Q	Q
b1-04	Reverse Operation Selection Reverse Oper	Determines the forward rotation of the motor, and if reverse operation is disabled. 0: Reverse Enabled 1: Reverse Disabled 2: Exchange Phase - Change direction of forward motor rotation.	0 to 2	0	A	A	A	A
b1-05	Minimum Output Frequency (E1-09) or Less Operation Selection Zero-Speed Oper	Operation method when frequency reference is less than minimum output frequency set in E1-09. 0: Operates according to frequency reference (E1-09 is disabled) 1: Output shuts off (coast to stop if less than E1-09) 2: Operates according to E1-09 (frequency reference set to E1-09) 3: Zero speed (frequency reference of zero is less than E1-09)	0 to 3	0	-	-	-	A
b1-06	Digital Input Scan Time Cntl Input Scans	Sets the scan rate of terminals S1 to S8. 0: 2ms - 2 scans (for quick response) 1: 5ms - 2 scans (for noisy environments)	0 to 1	1	A	A	A	A
b1-07	Local/Remote Run Selection LOC/REM RUN Sel	0: Cycle External RUN - If the run command is closed when switching from local mode to remote mode, the Drive will not run. 1: Accept External RUN - If the run command is closed when switching from local mode to remote mode, the Drive WILL run.	0 to 1	0	A	A	A	A
b1-08	Run Command Selection During Program RUN CMD at PRG	0: Disabled - Run command accepted only in the operation menu. 1: Enabled - Run command accepted in all menus (except when b1-02 = 0).	0 to 1	0	A	A	A	A
DC Injection Braking								
b2-01	DC Injection Braking Start Frequency DCInj Start Freq	Sets the frequency at which DC injection braking starts when ramp to stop (b1-03 = 0) is selected. If b2-01 < E1-09, DC Injection braking starts at E1-09.	0.0 to 10.0	0.5Hz	A	A	A	A
b2-02	DC Injection Braking Current DCInj Current	Sets the DC injection braking current as a percentage of the Drive rated current.	0 to 100	50%	A	A	A	-
b2-03	DC Injection Braking Time at Start DCInj Time @Start	Sets the time of DC injection braking at start in units of 0.01 seconds.	0.00 to 10.00	0.00sec	A	A	A	A
b2-04	DC Injection Braking Time at Stop DCInj Time @Stop	Sets the time length of DC injection braking at stop in units of 0.01 seconds. 1. When b1-03 = 2, actual DC Injection time is calculated as follows: b2-04 * 10 * Output Frequency / E1-04. 2. When b1-03 = 0, this parameter determines the amount of time DC Injection is applied to the motor at the end of the decel ramp. 3. This should be set to a minimum of 0.50 seconds when using HSB. This will activate DC injection during the final portion of HSB and help ensure that the motor stops completely.	0.00 to 10.00	0.00sec	A	A	A	A
b2-08	Magnetic Flux Compensation Capacity Field Comp	Sets the magnetic flux compensation as a percentage of the no-load current value (E2-03).	0 to 1000	0%	-	-	A	-
◆ Denotes that parameter can be changed when the Drive is running.								

Table A.1 F7 Parameter List (Continued)

Parameter No.	Parameter Name Digital Operator Display	Description	Setting Range	Factory Setting	Control Method			
					V/F	V/F w/ PG	Open Loop Vector	Flux Vector
Speed Search								
b3-01	Speed Search Selection SpdSrch at Start	Enables/disables and selects the speed search function at start. 0: Speed Estimation Speed Search Disable - Speed search at start is disabled (however the estimated speed method is used for multi-function input, power loss ride thru, auto fault retry) 1: Speed Estimation Speed Search Enable - The speed estimation method of speed search is enabled at run command. 2: Current Detection Speed Search Disable - Speed search at start is disabled (however the current detection method is used for multi-function input, power loss ride through, auto fault retry) 3: Current Detection Speed Search Enable - The current detection method of speed search is enabled at run command. Speed Estimation Method: Motor speed and direction are measured using residual motor flux. Current Detection Method: Motor speed is measured using current feedback levels (unidirectional only).	0 to 3	2	A	A	A	-
b3-02	Speed Search Deactivation Current SpdSrch Current	Used only when b3-01 = 2 or 3. Sets the speed search operation current as a percentage of Drive rated current.	0 to 200	120%	A	-	A	-
b3-03	Speed Search Deceleration Time SpdSrch Dec Time	Used only when b3-01 = 2 or 3. Sets the deceleration time during speed search.	0.1 to 10.0	2.0sec	A	-	A	-
b3-05	Speed Search Delay Time Search Delay	Delays the speed search operation after a momentary power loss to allow time for an external output contactor to re-energize.	0.0 to 20.0	0.2sec	A	A	A	A
b3-10	Speed Search Detection Compensation Gain Srch Detect Comp	Sets the gain for the frequency at which the Drive starts speed estimation speed search. Use only when b3-01 = 0 or 1.	1.00 to 1.20	1.10	A	-	A	-
b3-14	Bi-directional Speed Search Selection Bidir Search Sel	This parameter enables the Drive to detect the direction of rotation of the motor during speed search. 0: Disable - Drive uses frequency reference direction. 1: Enable - Drive uses detected direction	0 to 1	1	A	A	A	-
Delay Timers								
b4-01	Timer Function ON-Delay Time Delay-ON Timer	Used in conjunction with a multi-function digital input and a multi-function digital output programmed for the timer function. This sets the amount of time between when the digital input is closed, and the digital output is energized.	0.0 to 3000.0	0.0sec	A	A	A	A
b4-02	Timer Function OFF-Delay Time Delay-OFF Timer	Used in conjunction with a multi-function digital input and a multi-function digital output programmed for the timer function. This sets the amount of time the output stays energized after the digital input is opened.	0.0 to 3000.0	0.0sec	A	A	A	A
PID Control								
b5-01	PID Function Setting PID Mode	This parameter determines the function of the PID control. 0: Disabled 1: D = Feedback 2: D = Feed-Forward 3: Freq. Ref. + PID output (D = Feedback) 4: Freq. Ref. + PID output (D = Feed-Forward)	0 to 4	0	A	A	A	A
b5-02 ◆	Proportional Gain Setting PID Gain	Sets the proportional gain of the PID controller.	0.00 to 25.00	1.00	A	A	A	A
b5-03 ◆	Integral Time Setting PID I Time	Sets the integral time for the PID controller. A setting of zero disables integral control.	0.0 to 360.0	1.0sec	A	A	A	A
b5-04 ◆	Integral Limit Setting PID I Limit	Sets the maximum output possible from the integrator. Set as a percentage (%) of maximum frequency.	0.0 to 100.0	100.0%	A	A	A	A
b5-05 ◆	Derivative Time PID D Time	Sets D control derivative time. A setting of 0.00 disables derivative control.	0.00 to 10.00	0.00sec	A	A	A	A
b5-06 ◆	PID Output Limit PID Limit	Sets the maximum output possible from the entire PID controller. Set as a percentage (%) of maximum frequency.	0.00 to 100.0	100.0%	A	A	A	A

◆Denotes that parameter can be changed when the Drive is running.

Table A.1 F7 Parameter List (Continued)

Parameter No.	Parameter Name Digital Operator Display	Description	Setting Range	Factory Setting	Control Method			
					V/F	V/F w/ PG	Open Loop Vector	Flux Vector
b5-07 ◆	PID Offset Adjustment PID Offset	Sets the amount of offset of the output of the PID controller. Set as a percentage (%) of maximum frequency. The offset is summed with the PID output. This can be used to artificially kick-start a slow starting PID loop.	-100.0 to +100.0	0.0%	A	A	A	A
b5-08 ◆	PID Primary Delay Time Constant PID Delay Time	Sets the amount of time for the filter on the output of the PID controller.	0.00 to 10.00	0.00sec	A	A	A	A
b5-09	PID Output Level Selection Output Level Sel	Determines whether the PID controller will be direct or reverse acting. 0: Normal Output (direct acting) 1: Reverse Output (reverse acting)	0 to 1	0	A	A	A	A
b5-10	PID Output Gain Setting Output Gain	Sets the output gain of the PID controller.	0.0 to 25.0	1.0	A	A	A	A
b5-11	PID Output Reverse Selection Output Rev Sel	0: 0 limit (when PID output goes negative, Drive stops). 0 limit is automatic when reverse prohibit is selected using b1-04. 1: Reverse (when PID goes negative, Drive reverses).	0 to 1	0	A	A	A	A
b5-12	PID Feedback Reference Missing Detection Selection Fb los Det Sel	0: Disabled 1: Alarm 2: Fault	0 to 2	0	A	A	A	A
b5-13	PID Feedback Loss Detection Level Fb los Det Lvl	Sets the PID feedback loss detection level as a percentage (%) of maximum frequency (E1-04).	0 to 100	0%	A	A	A	A
b5-14	PID Feedback Loss Detection Time Fb los Det Time	Sets the PID feedback loss detection delay time in terms of seconds.	0.0 to 25.5	1.0sec	A	A	A	A
b5-15	PID Sleep Function Start Level PID Sleep Level	Sets the sleep function start frequency.	Varies by Duty Rating*	0.0Hz	A	A	A	A
b5-16	PID Sleep Delay Time PID Sleep Time	Sets the sleep function delay time in terms of seconds.	0.0 to 25.5	0.0sec	A	A	A	A
b5-17	PID Accel/Decel Time PID Acc/Dec Time	Applies an accel/decel time to the PID setpoint reference. The Drive's standard softstarter (C1-XX and S-curve) still affects the output of the PID algorithm.	0.0 to 25.5	0.0sec	A	A	A	A
b5-18	PID Setpoint Selection PID Setpoint Sel	Allows the b5-19 setting to be the PID target setpoint value. 0: Disabled 1: Enabled	0 to 1	0	A	A	A	A
b5-19	PID Setpoint Value PID Setpoint	Sets the PID target value. Use only when b5-18 = 1	0.0 to 100.0	0.0%	A	A	A	A

◆Denotes that parameter can be changed when the Drive is running.
* For Heavy Duty (HD) Rating (C6-01=0): Setting Range=0.0 to 300.0. For Normal Duty (ND) Rating (C6-01=2): Setting Range=0.0 to 400.0.

Table A.1 F7 Parameter List (Continued)

Parameter No.	Parameter Name Digital Operator Display	Description	Setting Range	Factory Setting	Control Method			
					V/F	V/F w/ PG	Open Loop Vector	Flux Vector
Reference Hold (Dwell)								
b6-01	Dwell Reference at Start Dwell Ref @Start	Temporarily holds the frequency reference. 	0.0 to 400.0	0.0Hz	A	A	A	A
b6-02	Dwell Time at Start Dwell Time @Start		0.0 to 10.0	0.0sec	A	A	A	A
b6-03	Dwell Frequency at Stop Dwell Ref @Stop		0.0 to 400.0	0.0Hz	A	A	A	A
b6-04	Dwell Time at Stop Dwell Time @Stop		0.0 to 10.0	0.0sec	A	A	A	A
Droop Control								
b7-01 ◆	Droop Control Level Droop Quantity	Sets the speed decrease as a percentage of motor base speed (E1-06) when the motor is at 100% load torque. Setting of 0.0 disables droop control.	0.0 to 100.0	0.0%	-	-	-	A
b7-02 ◆	Droop Control Delay Time Droop Delay Time	Determines the droop control delay time in response to a load change.	0.03 to 2.00	0.05sec	-	-	-	A
Energy Saving								
b8-01	Energy Saving Control Selection Energy Save Sel	Energy Savings function enable/disable selection. 0: Disabled 1: Enabled	0 to 1	0	A	A	A	A
b8-02	Energy Saving Gain Energy Save Gain	Sets energy savings control gain when in vector control method.	0.0 to 10.0	1.0	-	-	A	A
b8-03	Energy Saving Control Filter Time Constant Energy Saving FT	Sets energy saving control filter time constant when in vector control method.	0.00 to 10.00	Varies by kVA	-	-	A	A
b8-04	Energy Saving Coefficient Value Energy Save COEF	Used to fine-tune the energy savings function when in V/F control method.	0.0 to 655.00	Varies by kVA	A	A	-	-
b8-05	Power Detection Filter Time kW Filter Time		0 to 2000	20ms	A	A	-	-
b8-06	Search Operation Voltage Limit Search V Limit		0 to 100	0%	A	A	-	-
Zero Servo								
b9-01	Zero Servo Gain Zero Servo Gain	Sets the position loop gain for Zero Servo command. This function is effective when multi-function input "zero servo command" is set.	0 to 100	5	-	-	-	A
b9-02	Zero Servo Completion Width Zero Servo Count	Sets number of pulses used for the multi-function output of "zero servo completion".	0 to 16383	10 pulses	-	-	-	A
◆Denotes that parameter can be changed when the Drive is running.								

Table A.1 F7 Parameter List (Continued)

Parameter No.	Parameter Name Digital Operator Display	Description	Setting Range	Factory Setting	Control Method			
					V/F	V/F w/ PG	Open Loop Vector	Flux Vector
Accel / Decel								
C1-01 ◆	Acceleration Time 1 Accel Time 1	Sets the time to accelerate from zero to maximum frequency.	0.0 to 6000.0	10.0sec	Q	Q	Q	Q
C1-02 ◆	Deceleration Time 1 Decel Time 1	Sets the time to decelerate from maximum frequency to zero.			Q	Q	Q	Q
C1-03 ◆	Acceleration Time 2 Accel Time 2	Sets the time to accelerate from zero to maximum frequency when selected via a multi-function input.			A	A	A	A
C1-04 ◆	Deceleration Time 2 Decel Time 2	Sets the time to decelerate from maximum frequency to zero when selected via a multi-function input.			A	A	A	A
C1-05	Acceleration Time 3 Accel Time 3	Sets the time to accelerate from zero to maximum frequency when selected via a multi-function input.			A	A	A	A
C1-06	Deceleration Time 3 Decel Time 3	Sets the time to decelerate from maximum frequency to zero when selected via a multi-function input.			A	A	A	A
C1-07	Acceleration Time 4 Accel Time 4	Sets the time to accelerate from zero to maximum frequency when selected via a multi-function input.			A	A	A	A
C1-08	Deceleration Time 4 Decel Time 4	Sets the time to decelerate from maximum frequency to zero when selected via a multi-function input.			A	A	A	A
C1-09	Fast Stop Time Fast Stop Time	Sets the time to decelerate from maximum frequency to zero for the multi-function input "Fast Stop" function.	0.0 to 6000.0	10.0sec	A	A	A	A
C1-10	Accel/Decel Time Setting Unit Acc/Dec Units	Sets the setting resolution of C1-01 to C1-09 0: 0.01 sec (0.00 to 600.00 sec) 1: 0.1 sec (0.0 to 600.0 sec)	0 to 1	1	A	A	A	A
C1-11	Accel/Decel Switch Frequency Acc/Dec SW Freq	Sets the frequency for automatic switching of accel / decel times. Fout < C1-11: Accel/Decel Time 4 Fout ≥ C1-11: Accel/Decel Time 1 Multi-function inputs "Multi-Acc/Dec 1" and "Multi-Acc/Dec 2" have priority over C1-11.	Varies by Duty Rating*	0.0Hz	A	A	A	A
S-Curve Accel/Decel								
C2-01	S-Curve Characteristic at Accel Start SCrv Acc @ Start	<p>S-curve is used to further soften the starting and stopping ramp. The longer the S-curve time, the softer the starting and stopping ramp.</p>	0.00 to 2.50	0.20sec	A	A	A	A
C2-02	S-Curve Characteristic at Accel End SCrv Acc @ End			0.20sec	A	A	A	A
C2-03	S-Curve Characteristic at Decel Start SCrv Dec @ Start			0.20sec	A	A	A	A
C2-04	S-Curve Characteristic at Decel End SCrv Dec @ End			0.00sec	A	A	A	A
<p>◆ Denotes that parameter can be changed when the Drive is running. * For Heavy Duty (HD) Rating: Setting Range=0.0 to 300.0. For Normal Duty (ND) Rating: Setting Range=0.0 to 400.0.</p>								

Table A.1 F7 Parameter List (Continued)

Parameter No.	Parameter Name Digital Operator Display	Description	Setting Range	Factory Setting	Control Method			
					V/F	V/F w/ PG	Open Loop Vector	Flux Vector
Motor-Slip Compensation								
C3-01 ◆	Slip Compensation Gain Slip Comp Gain	This parameter is used to increase motor speed to account for motor slip by boosting the output frequency. If the speed is lower than the frequency reference, increase C3-01. If the speed is higher than the frequency reference, decrease C3-01.	0.0 to 2.5	1.0	A	-	A	A
C3-02	Slip Compensation Primary Delay Time Slip Comp Time	This parameter adjusts the filter on the output of the slip compensation function. Increase to add stability, decrease to improve response.	0 to 10000	200ms	A	-	A	-
C3-03	Slip Compensation Limit Slip Comp Limit	This parameter sets the upper limit for the slip compensation function. It is set as a percentage of motor rated slip (E2-02).	0 to 250	200%	A	-	A	-
C3-04	Slip Compensation Selection During Regeneration Slip Comp Regen	Determines whether slip compensation is enabled or disabled during regenerative operation. 0: Disabled 1: Enabled	0 to 1	0	A	-	A	-
C3-05	Output Voltage Limit Operation Selection V/F Slip Cmp Sel	Determines if the motor magnetic flux is automatically decreased when output voltage saturation occurs. 0: Disabled 1: Enabled	0 to 1	0	-	-	A	A
Torque Compensation								
C4-01 ◆	Torque Compensation Gain Torq Comp Gain	This parameter sets the gain for the Drive's automatic torque boost function to match the Drive's output voltage to the motor load. This parameter helps to produce better starting torque. It determines the amount of torque or voltage boost based upon motor current, motor resistance, and output frequency.	0.00 to 2.50	1.00	A	A	A	-
C4-02	Torque Compensation Primary Delay Time Torq Comp Time	This parameter adjusts the filter on the output of the torque compensation function. Increase to add stability, decrease to improve response.	0 to 10000	20ms	A	A	A	-
C4-03	Torque Compensation at Forward Start F TorqCmp @ start	Sets torque compensation at forward start as a percentage of motor torque.	0.0 to 200.0	0.0%	-	-	A	-
C4-04	Torque Compensation at Reverse Start R TorqCmp @ start	Sets torque compensation at reverse start as a percentage of motor torque.	-200.0 to 0.0	0.0%	-	-	A	-
C4-05	Torque Compensation Time Constant TorqCmp Delay T	Sets the time constant for torque compensation at forward start and reverse start (C4-03 and C4-04). The filter is disabled if the time is set to 4ms or less.	0 to 200	10ms	-	-	A	-
◆Denotes that parameter can be changed when the Drive is running.								

Table A.1 F7 Parameter List (Continued)

Parameter No.	Parameter Name Digital Operator Display	Description	Setting Range	Factory Setting	Control Method			
					V/F	V/F w/ PG	Open Loop Vector	Flux Vector
ASR Tuning								
C5-01 ◆	ASR Proportional Gain 1 ASR P Gain 1	Sets the proportional gain of the speed control loop (ASR)	1.00 to 300.00	20.00	-	A	-	A
C5-02 ◆	ASR Integral Time 1 ASR I Time 1	Sets the integral time of the speed control loop (ASR)	0.000 to 10.000	0.500 sec	-	A	-	A
C5-03 ◆	ASR Proportional Gain 2 ASR P Gain 2	Sets the speed control gain 2 and integral time 2 of the speed control loop (ASR).	1.00 to 300.00	20.00	-	A	-	A
C5-04 ◆	ASR Integral Time 2 ASR I Time 2		0.000 to 10.000	0.500 sec	-	A	-	A
C5-05	ASR Limit ASR Limit	Sets the upper limit for the speed control loop (ASR) as a percentage of the maximum output frequency (E1-04).	0.0 to 20.0	5.0%	-	A	-	-
C5-06	ASR Primary Delay Time Constant ASR Delay Time	Sets the filter time constant for the time from the speed loop to the torque command output.	0.000 to 0.500	0.004 sec	-	-	-	A
C5-07	ASR Gain Switching Frequency ASR Gain SW Freq	Sets the frequency for switching between Proportional Gain 1, 2 and Integral Time 1, 2.	0.0 to 400.0	0.0Hz	-	-	-	A
C5-08	ASR Integral Limit ASR I Limit	Sets the ASR integral upper limit and rated load as a percentage of maximum output frequency (E1-04).	0 to 400	400%	-	-	-	A
Carrier Frequency								
C6-01	Drive Duty Selection Heavy/Normal Duty	Selects Drive's rated input and output current, overload capacity, carrier frequency, current limit, and maximum output frequency. See Introduction for details. 0: Heavy Duty (C6-02 = 0 to 1) 1: Normal Duty 1 (C6-02 = 0 to F) 2: Normal Duty 2 (C6-02 = 0 to F)	0 to 2	0	A	A	A	A
C6-02	Carrier Frequency Selection CarrierFreq Sel	Selects the number of pulses per second of the output voltage waveform. Setting range determined by C6-01 setting. 0: Low noise 1: Fc = 2.0 kHz 2: Fc = 5.0 kHz 3: Fc = 8.0 kHz 4: Fc = 10.0 kHz 5: Fc = 12.5 kHz 6: Fc = 15.0 kHz F: Program (Determined by the settings of C6-03 thru C6-05)	0 to F	Varies by kVA	Q	Q	Q	Q
C6-03	Carrier Frequency Upper Limit CarrierFreq Max	Maximum carrier frequency allowed when C6-02 = F.	2.0 to 15.0 kHz	Varies by kVA	A	A	A	A
C6-04	Carrier Frequency Lower Limit CarrierFreq Min	Minimum carrier frequency allowed when C6-02 = F.	0.4 to 15.0 kHz	Varies by kVA	A	A	-	-
C6-05	Carrier Frequency Proportional Gain CarrierFreq Gain	Sets the relationship of output frequency to carrier frequency when C6-02 = F.	0 to 99	0	A	A	-	-
◆Denotes that parameter can be changed when the Drive is running.								

Table A.1 F7 Parameter List (Continued)

Parameter No.	Parameter Name Digital Operator Display	Description	Setting Range	Factory Setting	Control Method			
					V/F	V/F w/ PG	Open Loop Vector	Flux Vector
Preset Reference								
d1-01 ◆	Frequency Reference 1 Reference 1	Setting units are affected by o1-03.	0.00 to E1-04 Value	0.00Hz	Q	Q	Q	Q
d1-02 ◆	Frequency Reference 2 Reference 2	Frequency reference when multi-function input “Multi-step speed reference 1” is ON. Setting units are affected by o1-03.		0.00Hz	Q	Q	Q	Q
d1-03 ◆	Frequency Reference 3 Reference 3	Frequency reference when multi-function input “Multi-step speed reference 2” is ON. Setting units are affected by o1-03.		0.00Hz	Q	Q	Q	Q
d1-04 ◆	Frequency Reference 4 Reference 4	Frequency reference when multi-function input “Multi-step speed reference 1,2” is ON. Setting units are affected by o1-03.		0.00Hz	Q	Q	Q	Q
d1-05 ◆	Frequency Reference 5 Reference 5	Frequency reference when multi-function input “Multi-step speed reference 3” is ON. Setting units are affected by o1-03.		0.00Hz	A	A	A	A
d1-06 ◆	Frequency Reference 6 Reference 6	Frequency reference when multi-function input “Multi-step speed reference 1,3” is ON. Setting units are affected by o1-03.		0.00Hz	A	A	A	A
d1-07 ◆	Frequency Reference 7 Reference 7	Frequency reference when multi-function input “Multi-step speed reference 2,3” is ON. Setting units are affected by o1-03.		0.00Hz	A	A	A	A
d1-08 ◆	Frequency Reference 8 Reference 8	Frequency reference when multi-function input “Multi-step speed reference 1,2,3” is ON. Setting units are affected by o1-03.		0.00Hz	A	A	A	A
d1-09 ◆	Frequency Reference 9 Reference 9	Frequency reference when multi-function input “Multi-step speed reference 4” is ON. Setting units are affected by o1-03.		0.00Hz	A	A	A	A
d1-10 ◆	Frequency Reference 10 Reference 10	Frequency reference when multi-function input “Multi-step speed reference 1,4” is ON. Setting units are affected by o1-03.		0.00Hz	A	A	A	A
d1-11 ◆	Frequency Reference 11 Reference 11	Frequency reference when multi-function input “Multi-step speed reference 2,4” is ON. Setting units are affected by o1-03.		0.00Hz	A	A	A	A
d1-12 ◆	Frequency Reference 12 Reference 12	Frequency reference when multi-function input “Multi-step speed reference 1,2,4” is ON. Setting units are affected by o1-03.		0.00Hz	A	A	A	A
d1-13 ◆	Frequency Reference 13 Reference 13	Frequency reference when multi-function input “Multi-step speed reference 3,4” is ON. Setting units are affected by o1-03.		0.00Hz	A	A	A	A
d1-14 ◆	Frequency Reference 14 Reference 14	Frequency reference when multi-function input “Multi-step speed reference 1,3,4” is ON. Setting units are affected by o1-03.		0.00Hz	A	A	A	A
d1-15 ◆	Frequency Reference 15 Reference 15	Frequency reference when multi-function input “Multi-step speed reference 2,3,4” is ON. Setting units are affected by o1-03.		0.00Hz	A	A	A	A
d1-16 ◆	Frequency Reference 16 Reference 16	Frequency reference when multi-function input “Multi-step speed reference 1,2,3,4” is ON. Setting units are affected by o1-03.		0.00Hz	A	A	A	A
d1-17 ◆	Jog Frequency Reference Jog Reference	Frequency reference when: “Jog frequency reference” is selected via multi-function input terminals. “Jog frequency reference” has priority over “multi-step speed reference 1 to 4”. d1-17 is also the reference for the JOG key on the Digital Operator, and the multi-function inputs “forward jog” and “reverse jog”. Setting units are affected by o1-03.		6.00Hz	Q	Q	Q	Q
Reference Limits								
d2-01	Frequency Reference Upper Limit Ref Upper Limit	Determines maximum frequency reference, set as a percentage of maximum output frequency (E1-04). If the frequency reference is above this value, actual Drive speed will be limited to this value. This parameter applies to all frequency reference sources.	0.0 to 110.0	100.0%	A	A	A	A
d2-02	Frequency Reference Lower Limit Ref Lower Limit	Determines minimum frequency reference, set as a percentage of maximum output frequency (E1-04). If frequency reference is below this value, actual Drive speed will be set to this value. This parameter applies to all frequency reference sources.	0.0 to 110.0	0.0%	A	A	A	A
d2-03	Master Speed Reference Lower Limit Ref1 Lower Limit	Determines minimum frequency reference, set as a percentage of maximum output frequency (E1-04). If frequency reference from analog input (A1, A2, and A3) is below this value, actual Drive speed will be set to this value. This parameter applies only to analog inputs A1, A2, and A3.	0.0 to 110.0	0.0%	A	A	A	A
◆Denotes that parameter can be changed when the Drive is running.								

Table A.1 F7 Parameter List (Continued)

Parameter No.	Parameter Name Digital Operator Display	Description	Setting Range	Factory Setting	Control Method			
					V/F	V/F w/ PG	Open Loop Vector	Flux Vector
Jump Frequencies								
d3-01	Jump Frequency 1 Jump Freq 1	These parameters allow programming of up to three prohibited frequency reference points for eliminating problems with resonant vibration of the motor / machine. This feature does not actually eliminate the selected frequency values, but will accelerate and decelerate the motor through the prohibited bandwidth.	Varies by Duty Rating*	0.0Hz	A	A	A	A
d3-02	Jump Frequency 2 Jump Freq 2			0.0Hz	A	A	A	A
d3-03	Jump Frequency 3 Jump Freq 3			0.0Hz	A	A	A	A
d3-04	Jump Frequency Width Jump Bandwidth	This parameter determines the width of the deadband around each selected prohibited frequency reference point. A setting of "1.0" will result in a deadband of +/- 1.0Hz.	0.0 to 20.0	1.0Hz	A	A	A	A
Sequence (MOP & Trim Control)								
d4-01	Frequency Reference Hold Function Selection MOP Ref Memory	This parameter is used to retain the held frequency reference in U1-01 (d1-01) when power is removed. This function is available when the multi-function inputs "accel/decel ramp hold" or "up/down" commands are selected (H1-XX = A or 10 and 11). 0: Disabled 1: Enabled	0 to 1	0	A	A	A	A
d4-02	Trim Control Level Trim Control Lvl	Sets the amount of frequency reference to be added or subtracted as a percentage of maximum output frequency (E1-04) when multi-function inputs "trim control increase" and "trim control decrease" are selected (H1-XX = 1C and 1D).	0 to 100	10%	A	A	A	A
Torque Control								
d5-01	Torque Control Selection Torq Control Sel	Selects speed or torque control. The torque reference is set via analog input A2 or A3 when it is set for "torque reference" (H3-05 or H3-09 = 13). Torque reference is set as a percentage of motor rated torque. To use this function for switching between speed and torque control, set to 0 and set a multi-function input to "speed/torque control change" (H1-XX = 71). 0: Speed Control (controlled by C5-01 to C5-07) 1: Torque Control	0 to 1	0	-	-	-	A
d5-02	Torque Reference Delay Time Torq Ref Filter	Sets the torque reference delay time in ms units. This function can be used to correct for noise in the torque control signal or the responsiveness with the host controller. When oscillation occurs during torque control, increase the set value.	0 to 1000	0ms	-	-	-	A
d5-03	Speed Limit Selection Speed Limit Sel	Sets the speed limit command method for the torque control method. 1: Analog Input - Limited by the output of the soft starter (b1-01 selection and active acceleration/deceleration and S-curve settings). 2: Program Setting - Limited by d5-04 setting value.	1 to 2	1	-	-	-	A
d5-04	Speed Limit Speed Lmt Value	Sets the speed limit during torque control as a percentage of the maximum output frequency (E1-04). This function is enabled when d5-03 is set to 2. Directions are as follows. +: run command direction -: run command opposite direction	-120 to 120	0%	-	-	-	A
d5-05	Speed Limit Bias Speed Lmt Bias	Sets the speed limit bias as a percentage of the maximum output frequency (E1-04). Bias is given to the specified speed limit. It can be used to adjust the margin for the speed limit.	0 to 120	10%	-	-	-	A
d5-06	Speed/Torque Control Switchover Timer Ref Hold Time	Set the delay time from inputting the multi-function input "speed/torque control change" (from On to OFF or OFF to ON) until the control is actually changed. This function is enabled when the multi-function input "speed/torque control change" (H1-XX = 71) is set. While in the speed/torque control switching timer, the analog inputs hold the value present when the "speed/torque control change" is received.	0 to 1000	0ms	-	-	-	A
<p>◆ Denotes that parameter can be changed when the Drive is running. * For Heavy Duty (HD) Rating: Setting Range=0.0 to 300.0. For Normal Duty (ND) Rating: Setting Range=0.0 to 400.0.</p>								

Table A.1 F7 Parameter List (Continued)

Parameter No.	Parameter Name Digital Operator Display	Description	Setting Range	Factory Setting	Control Method			
					V/F	V/F w/ PG	Open Loop Vector	Flux Vector
Field-Weakening								
d6-01	Magnetic Field Weakening Level Field-Weak Lvl	Sets the Drive output voltage when the multi-function input “field weakening command” is input (H1-XX = 63). Sets as a percentage taking the voltage set in the V/F pattern as 100%.	0 to 100	80%	A	A	-	-
d6-02	Magnetic Field Frequency Field-Weak Freq	Sets the lower limit (in Hz) of the frequency range where field weakening control is valid. The field weakening command is valid only at frequencies above this setting and only when output frequency is in agreement with the current output frequency (speed agree).	Varies by Duty Rating*	0.0Hz	A	A	-	-
d6-03	Magnetic Field Forcing Function Selection Field Force Sel	Sets the magnetic field forcing function. 0: Disabled 1: Enabled	0 to 1	0	-	-	-	A
d6-06	Magnetic Field Forcing Limit Field Force Limit	Sets the upper limit of the excitation current command during magnetic field forcing. A setting of 100% is equal to motor no-load current, E2-03.	100 to 400	400%	-	-	A	A
V/F Pattern								
E1-01	Input Voltage Setting Input Voltage	Set to the nominal voltage of the incoming line. Sets the maximum and base voltage used by preset V/F patterns (E1-03 = 0 to E), adjusts the levels of Drive protective features (e.g. Overvoltage, braking resistor turn-on, stall prevention, etc.). ⚠ WARNING DRIVE INPUT VOLTAGE (NOT MOTOR VOLTAGE) MUST BE SET IN E1-01 FOR THE PROTECTIVE FEATURES OF THE DRIVE TO FUNCTION PROPERLY. FAILURE TO DO SO MAY RESULT IN EQUIPMENT DAMAGE AND/OR PERSONAL INJURY.	155 to 255.0 (240V) 310 to 510.0 (480V)	240V or 480V	Q	Q	Q	Q
E1-03	V/F Pattern Selection V/F Selection	Set to the type of motor being used and the type of application. The Drive operates utilizing a set V/F pattern to determine the appropriate output voltage level for each commanded speed. There are 15 different preset V/F patterns to select from (E1-03 = 0 to E) with varying voltage profiles, base levels (base level = frequency at which maximum voltage is reached), and maximum frequencies. There are also settings for Custom V/F patterns that will use the settings of parameters E1-04 through E1-13. E1-03 = F selects a custom V/F pattern with an upper voltage limit and E1-03 = FF selects a custom V/F pattern without an upper voltage limit. 0: 50Hz 1: 60Hz Saturation 2: 50Hz Saturation 3: 72Hz (60Hz Base) 4: 50Hz VT1 5: 50Hz VT2 6: 60Hz VT1 7: 60Hz VT2 8: 50Hz HST1 9: 50Hz HST2 A: 60Hz HST1 B: 60Hz HST2 C: 90Hz (60Hz Base) D: 120Hz (60Hz Base) E: 180Hz (60Hz Base) F: Custom V/F FF: Custom w/o limit	0 to FF	F	Q	Q	-	-
<p>◆ Denotes that parameter can be changed when the Drive is running. * For Heavy Duty (HD) Rating: Setting Range=0.0 to 300.0. For Normal Duty (ND) Rating: Setting Range=0.0 to 400.0.</p>								

Table A.1 F7 Parameter List (Continued)

Parameter No.	Parameter Name Digital Operator Display	Description	Setting Range	Factory Setting	Control Method				
					V/F	V/F w/ PG	Open Loop Vector	Flux Vector	
E1-04	Maximum Output Frequency Max Frequency	<p>These parameters are only applicable when V/F Pattern Selection is set to Custom (E1-03 = F or FF). To set V/F characteristics in a straight line, set the same values for E1-07 and E1-09. In this case, the setting for E1-08 will be disregarded. Be sure that the four frequencies are set in the following manner or else an OPE10 fault will occur: $E1-04 \geq E1-11 \geq E1-06 > E1-07 \geq E1-09$</p> <p>Note: Setting parameter E1-01=0 is also acceptable</p>	Varies by Duty Rating*	60.0Hz	Q	Q	Q	Q	
E1-05	Maximum Output Voltage Max Voltage		0.0 to 255.0 (240V) 0.0 to 510.0 (480V)	230V or 460V	Q	Q	Q	Q	
E1-06	Base Frequency Base Frequency		0.0 to 400.0	60.0Hz	Q	Q	Q	Q	
E1-07	Mid Output Frequency A Mid Frequency A		0.0 to 400.0	3.0Hz	A	A	A	-	
E1-08	Mid Output Voltage A Mid Voltage A		0.0 to 255.0 (240V) 0.0 to 510.0 (480V)	12.6 Vac	A	A	A	-	
E1-09	Minimum Output Frequency Min Frequency		0.0 to 400.0	0.5Hz	Q	Q	Q	A	
E1-10	Minimum Output Voltage Min Voltage		0.0 to 255.0 (240V) 0.0 to 510.0 (480V)	2.3 Vac	A	A	A	-	
E1-11	Mid Output Frequency B Mid Frequency B		0.0 to 400.0	0.0Hz	A	A	A	A	
E1-12	Mid Output Voltage B Mid Voltage B		Set only when the V/F pattern is finely adjusted in the constant power (HP) area above base speed. Adjustment is not normally required.	0.0 to 255.0 (240V) 0.0 to 510.0 (480V)	0.0Vac	A	A	A	A
E1-13	Base Voltage Base Voltage		Set only when the V/F pattern is finely adjusted in the constant power (HP) area above base speed. Adjustment is not normally required. If E1-13 = 0.0, then value in E1-05 is used for E1-13. Auto-Tuning sets this value.	0.0 to 255.0 (240V) 0.0 to 510.0 (480V)	0.0Vac	A	A	Q	Q

◆Denotes that parameter can be changed when the Drive is running.

* For Heavy Duty (HD) Rating: Setting Range=40.0 to 300.0. For Normal Duty (ND) Rating: Setting Range=40.0 to 400.0.

Table A.1 F7 Parameter List (Continued)

Parameter No.	Parameter Name Digital Operator Display	Description	Setting Range	Factory Setting	Control Method			
					V/F	V/F w/ PG	Open Loop Vector	Flux Vector
Motor Setup								
E2-01	Motor Rated Current Motor Rated FLA	Set to the motor nameplate full load current in amperes (A). This value is automatically set during Auto-Tuning.	Varies by kVA	Varies by kVA	Q	Q	Q	Q
E2-02	Motor Rated Slip Motor Rated Slip	Set to the motor rated slip in hertz (Hz). This value is automatically set during rotational Auto-Tuning.	Varies by kVA	Varies by kVA	A	A	A	A
E2-03	Motor No-Load Current No-Load Current	Set to the magnetizing current of the motor as a percentage of full load amps (E2-01). This value is automatically set during rotational Auto-Tuning.	Varies by kVA	Varies by kVA	A	A	A	A
E2-04	Number of Motor Poles Number of Poles	Set to the number of motor poles. This value is automatically set during Auto-Tuning.	2 to 48	4	-	Q	-	Q
E2-05	Motor Line-to-Line Resistance Term Resistance	Set to the phase-to-phase motor resistance in ohms (Ω). This value is automatically set by Auto-Tuning.	0.000 to 65.000	Varies by kVA	A	A	A	A
E2-06	Motor Leakage Inductance Leak Inductance	Set to the voltage drop due to motor leakage inductance as a percentage of motor rated voltage. This value is automatically set during Auto-Tuning.	0.0 to 40.0%	Varies by kVA	-	-	A	A
E2-07	Motor Iron-core Saturation Coefficient 1 Saturation Comp 1	Set to the motor iron saturation coefficient at 50% of magnetic flux. This value is automatically set during rotational Auto-Tuning.	0.00 to 0.50	0.50	-	-	A	A
E2-08	Motor Iron-core Saturation Coefficient 2 Saturation Comp 2	Set to the motor iron saturation coefficient at 75% of magnetic flux. This value is automatically set during rotational Auto-Tuning.	0.50 to 0.75	0.75	-	-	A	A
E2-09	Motor Mechanical Loss Mechanical Loss	Set to the motor mechanical loss as a percentage of motor rated power (kW) capacity. Adjust in the following circumstances: <ul style="list-style-type: none"> • When torque loss is large due to motor bearing friction. • When the torque loss in the load is large. 	0.0 to 10.0	0.0%	-	-	A	A
E2-10	Motor Iron Loss for Torque Compensation Tcomp Iron Loss	Set to the motor iron loss in watts (W).	0 to 65535 W	Varies by kVA	A	A	-	-
E2-11	Motor Rated Output Mtr Rated Power	Set to the motor rated power in kilowatts (kW). This value is automatically set during Auto-Tuning. 1HP = 0.746kW	0.00 to 650.00 kW	Varies by kVA	Q	Q	Q	Q

◆Denotes that parameter can be changed when the Drive is running.

Table A.1 F7 Parameter List (Continued)

Parameter No.	Parameter Name Digital Operator Display	Description	Setting Range	Factory Setting	Control Method			
					V/F	V/F w/ PG	Open Loop Vector	Flux Vector
V/F Pattern 2								
E3-01	Motor 2 Control Method Selection Control Method	0: V/F control 1: V/F control with PG 2: Open-loop vector control 3: Flux vector control	0 to 3	2	A	A	A	A
E3-02	Motor 2 Maximum Output Frequency Max Frequency	<p>Output voltage (V)</p> <p>Frequency (Hz)</p> <p>To set V/F characteristics in a straight line, set the same values for E3-05 and E3-07. In this case, the setting for E3-06 will be disregarded. Be sure that the four frequencies are set in the following manner or else an OPE10 fault will occur: E3-02 ≥ E3-04 ≥ E3-05 ≥ E3-07</p>	Varies by Duty Rating*	60.0Hz	A	A	A	A
E3-03	Motor 2 Maximum Output Voltage Max Voltage		0.0 to 255.0 (240V) 0.0 to 510.0 (480V)	230.0V or 460.0V	A	A	A	A
E3-04	Motor 2 Base Frequency Base Frequency		0.0 to 400.0	60.0Hz	A	A	A	A
E3-05	Motor 2 Mid Output Frequency Mid Frequency		0.0 to 400.0	3.0Hz	A	A	A	-
E3-06	Motor 2 Mid Output Voltage VA Mid Voltage		0.0 to 255.0 (240V) 0.0 to 510.0 (480V)	12.6 Vac	A	A	A	-
E3-07	Motor 2 Minimum Output Frequency Min Frequency		0.0 to 400.0	0.5Hz	A	A	A	A
E3-08	Motor 2 Minimum Output Voltage Min Voltage		0.0 to 255.0 (240V) 0.0 to 510.0 (480V)	2.3Vac	A	A	A	-
Motor Setup 2								
E4-01	Motor 2 Rated Current Motor Rated FLA	Set to the motor 2 nameplate full load current in amperes (A). This value is automatically set during Auto-Tuning.	Varies by kVA	Varies by kVA	A	A	A	A
E4-02	Motor 2 Rated Slip Motor Rated Slip	Set to the rated slip of motor 2 in hertz (Hz). This value is automatically set during rotational Auto-Tuning.	Varies by kVA	Varies by kVA	A	A	A	A
E4-03	Motor 2 No-Load Current No-Load Current	Set to the magnetizing current of motor 2 in percentage of full load current (E4-01). This value is automatically set during rotational Auto-Tuning.	Varies by kVA	Varies by kVA	A	A	A	A
E4-04	Motor 2 Number of Poles Number of Poles	Set to the number of poles of motor 2. This value is automatically set during Auto-Tuning.	2 to 48	4	-	A	-	A
E4-05	Motor 2 Line-to-Line Resistance Term Resistance	Set to the phase-to-phase resistance of motor 2 in ohms (Ω). This value is automatically set by the Auto-Tuning.	0.000 to 65.000	Varies by kVA	A	A	A	A
E4-06	Motor 2 Leakage Inductance Leak Inductance	Set to the voltage drop due to motor leakage inductance as a percentage of rated voltage of motor 2. This value is automatically set during Auto-Tuning.	0.0 to 40.0%	Varies by kVA	-	-	A	A
E4-07	Motor 2 Rated Output Mtr Rated Power	Set to the rated power of motor 2 in kilowatts (kW). This value is automatically set during Auto-Tuning.	0.00 to 650.00 kW	Varies by kVA	A	A	A	A

◆Denotes that parameter can be changed when the Drive is running.

* For Heavy Duty (HD) Rating: Setting Range=40.0 to 300.0. For Normal Duty (ND) Rating: Setting Range=40.0 to 400.0.

Table A.1 F7 Parameter List (Continued)

Parameter No.	Parameter Name Digital Operator Display	Description	Setting Range	Factory Setting	Control Method			
					V/F	V/F w/ PG	Open Loop Vector	Flux Vector
PG Option Setup								
F1-01	PG Parameter PG Pulses/Rev	Sets the number of pulses per revolution (PPM) of the encoder (pulse generator).	0 to 60000	1024	-	Q	-	Q
F1-02	Operation Selection at PG Open Circuit (PGO) PG Fdbk Loss Sel	Sets stopping method when a PG open circuit fault (PGO) occurs. See parameter F1-14. 0: Ramp to stop - Decelerate to stop using the active deceleration time. 1: Coast to stop 2: Fast - Stop - Decelerate to stop using the deceleration time in C1-09. 3: Alarm Only - Drive continues operation.	0 to 3	1	-	A	-	A
F1-03	Operation Selection at Overspeed (OS) PG Overspeed Sel	Sets the stopping method when an overspeed (OS) fault occurs. See F1-08 and F1-09. 0: Ramp to stop - Decelerate to stop using the active deceleration time. 1: Coast to stop 2: Fast - Stop - Decelerate to stop using the deceleration time in C1-09. 3: Alarm Only - Drive continues operation.	0 to 3	1	-	A	-	A
F1-04	Operation Selection at Deviation PG Deviation Sel	Sets the stopping method when a speed deviation (DEV) fault occurs. See F1-10 and F1-11. 0: Ramp to stop - Decelerate to stop using the active deceleration time. 1: Coast to stop 2: Fast - Stop - Decelerate to stop using the deceleration time in C1-09. 3: Alarm Only - Drive continues operation.	0 to 3	3	-	A	-	A
F1-05	PG Rotation Selection PG Rotation Sel	0: Fwd=C.C.W. - Phase A leads with forward run command. (Phase B leads with reverse run command.) 1: Fwd=C.W. - Phase B leads with forward run command. (Phase A leads with reverse run command.)	0 to 1	0	-	A	-	A
F1-06	PG Division Rate (PG Pulse Monitor) PG Output Ratio	Sets the division ratio for the pulse monitor of the PG-B2 encoder feedback option board. This function is not available with the PG-X2 option board. Division ratio = $(1 + n) / m$ ($n=0$ to 1 , $m=1$ to 32) The first digit of the value of F1-06 stands for n , the second and the third stand for m . (from left to right). The possible division ratio settings are: $1/32 \leq F1-06 \leq 1$	1 to 132	1	-	A	-	A
F1-07	Integral function during accel/decel selection PG Ramp PI/I Sel	Sets integral control during acceleration/deceleration to either enabled or disabled. 0: Disabled - The integral function is not used while accelerating or decelerating. 1: Enabled - The integral function is used at all times.	0 to 1	0	-	A	-	-
F1-08	Overspeed detection level PG Overspd Level	Configures the overspeed fault (OS) detection. OS fault will occur, if the motor speed feedback is greater than the F1-08 setting for a time longer than F1-09. F1-08 is set as a percentage of the maximum output frequency (E1-04). See F1-03.	0 to 120	115%	-	A	-	A
F1-09	Overspeed detection delay time PG Overspd Time		0.0 to 2.0	0.0 sec	-	A	-	A
F1-10	Excessive speed deviation detection level PG Deviate Level	Configures the speed deviation fault (DEV) detection. DEV fault will occur if the speed deviation is greater than the F1-10 setting for a time longer than F1-11. F1-10 is set as a percentage of the maximum output frequency (E1-04). Speed deviation is the difference between actual motor speed and the frequency reference command. See F1-04.	0 to 50	10%	-	A	-	A
F1-11	Excessive speed deviation detection delay time PG Deviate Time		0.0 to 10.0	0.5 sec	-	A	-	A

◆Denotes that parameter can be changed when the Drive is running.

Table A.1 F7 Parameter List (Continued)

Parameter No.	Parameter Name Digital Operator Display	Description	Setting Range	Factory Setting	Control Method			
					V/F	V/F w/ PG	Open Loop Vector	Flux Vector
F1-12	Number of PG gear teeth 1 PG # Gear Teeth1	Sets the gear ratio between the motor shaft and the encoder (PG). $\frac{\text{Input pulses from PG (PPR)} \times 60}{F1-01} \times \frac{F1-13}{F1-12}$ A gear ratio of 1 will be used if either of these parameters is set to 0. This function is not available in flux vector control.	0 to 1000	0	-	A	-	-
F1-13	Number of PG gear teeth 2 PG # Gear Teeth2			0	-	A	-	-
F1-14	PG open-circuit detection time PGO Detect Time	Configures the PG open (PGO) function. PGO will be detected if no PG pulses are detected for a time longer than F1-14. See F1-02.	0.0 to 10.0	2.0 sec	-	A	-	A
AI-14 Setup								
F2-01	AI-14 Input Selection AI-14 Input Sel	Sets the function for channel 1 to 3 of the AI-14B analog input reference option board. 0: 3-channel individual (Channel 1: terminal A1, Channel 2: terminal A2, Channel 3: terminal A3) 1: 3-channel addition (Summed values of channels 1 to 3 is the frequency reference) When set to 0, select 1 for b1-01. In this case, the multi-function input "Option/Inverter selection" cannot be used.	0 to 1	0	A	A	A	A
DI-08, 16 Setup								
F3-01	DI-08 / DI-16H2 Input Selection DI Input	Sets the function of the DI-08 or the DI-16H2 digital input option board. 0: BCD 1% unit 1: BCD 0.1% unit 2: BCD 0.01% unit 3: BCD 1Hz unit 4: BCD 0.1Hz unit 5: BCD 0.01Hz unit 6: BCD (5-digit) 0.01Hz unit (only effective when DI-16H2 is used.) 7: Binary input When o1-03 is set to 2 or higher, the input will be BCD, and the units will change to the o1-03 setting.	0 to 7	0	A	A	A	A
AO-08, 12 Setup								
F4-01	AO-08/AO-12 Channel 1 Monitor Selection AO Ch1 Sel	Sets the number of the monitor item to be output. (U1-□□) The following settings cannot be set: 4, 10 to 14, 25, 28, 29, 30, 34, 35, 39, 40, 41.	1 to 45	2	A	A	A	A
F4-02	AO-08/AO-12 Channel 1 Gain AO Ch1 Gain	Sets the channel 1 gain. Ex: Set F4-02 = 50% to output 100% at 5.0V output.	0.0 to 1000.0	100.0%	A	A	A	A
F4-03	AO-08/AO-12 Channel 2 Monitor Selection AO Ch2 Sel	Sets the number of the monitor item to be output. (U1-□□) The following settings cannot be set: 4, 10 to 14, 25, 28, 29, 30, 34, 39, 40, 41.	1 to 45	3	A	A	A	A
F4-04	AO-08/AO-12 Channel 2 Gain AO Ch2 Gain	Sets the channel 2 gain. Ex: Set F4-02 = 50% to output 100% at 5.0V output.	0.0 to 1000.0	50.0%	A	A	A	A
F4-05	AO-08/AO-12 Channel 1 Output Bias AO Ch1 Bias	Sets the channel 1 bias (100%/10V). Ex: Set F4-05 = 50% to output 0% at 5.0V output.	-110.0 to 110.0	0.0%	A	A	A	A
F4-06	AO-08/AO-12 Channel 2 Output Bias AO Ch2 Bias	Sets the channel 2 bias (100%/10V). Ex: Set F4-06 = 50% to output 0% at 5.0V output.	-110.0 to 110.0	0.0%	A	A	A	A
F4-07	AO-12 Channel 1 Signal Level AO Opt Level Ch1	Sets the range of the voltage output. 0: 0 to 10Vdc 1: -10 to +10Vdc	0 to 1	0	A	A	A	A
F4-08	AO-12 Channel 2 Signal Level AO Opt Level Ch2	Sets the range of the voltage output. 0: 0 to 10Vdc 1: -10 to +10Vdc	0 to 1	0	A	A	A	A

◆Denotes that parameter can be changed when the Drive is running.

Table A.1 F7 Parameter List (Continued)

Parameter No.	Parameter Name Digital Operator Display	Description	Setting Range	Factory Setting	Control Method			
					V/F	V/F w/ PG	Open Loop Vector	Flux Vector
DO-02, 08 Setup								
F5-01	DO-02/DO-08 Channel 1 Output Selection DO Ch1 Select	Sets the digital output function number for channel 1. See the H2 parameter group for possible selections. Effective when digital output card DO-02 or DO-08 is used.	0 to 37	0	A	A	A	A
F5-02	DO-02/DO-08 Channel 2 Output Selection DO Ch2 Select	Sets the digital output function number for channel 2. See the H2 parameter group for possible selections. Effective when digital output card DO-02 or DO-08 is used.	0 to 37	1	A	A	A	A
F5-03	DO-08 Channel 3 Output Selection DO Ch3 Select	Sets the digital output function number for channel 3. See the H2 parameter group for possible selections. Effective when digital output card DO-02 or DO-08 is used.	0 to 37	2	A	A	A	A
F5-04	DO-08 Channel 4 Output Selection DO Ch4 Select	Sets the digital output function number for channel 4. See the H2 parameter group for possible selections. Effective when digital output card DO-02 or DO-08 is used.	0 to 37	4	A	A	A	A
F5-05	DO-08 Channel 5 Output Selection DO Ch5 Select	Sets the digital output function number for channel 5. See the H2 parameter group for possible selections. Effective when digital output card DO-02 or DO-08 is used.	0 to 37	6	A	A	A	A
F5-06	DO-08 Channel 6 Output Selection DO Ch6 Select	Sets the digital output function number for channel 6. See the H2 parameter group for possible selections. Effective when digital output card DO-02 or DO-08 is used.	0 to 37	37	A	A	A	A
F5-07	DO-08 Channel 7 Output Selection DO Ch7 Select	Sets the digital output function number for channel 7. See the H2 parameter group for possible selections. Effective when digital output card DO-02 or DO-08 is used.	0 to 37	F	A	A	A	A
F5-08	DO-08 Channel 8 Output Selection DO Ch8 Select	Sets the digital output function number for channel 8. See the H2 parameter group for possible selections. Effective when digital output card DO-02 or DO-08 is used.	0 to 37	F	A	A	A	A
F5-09	DO-08 Output Mode Selection DO-08 Selection	Sets the function of the DO-08 digital output option board. 0: 8-channel individual outputs. 1: Binary code output. 2: 8-channel Selected - Output according to F5-01 to F5-08 settings.	0 to 2	0	A	A	A	A
Communications Option Setup								
F6-01	Operation Selection after Communication Error Comm Bus Flt Sel	Selects the stopping method for a communication option board fault (BUS). Active only when a communication option board is installed and b1-01 or b1-02 = 3. 0: Ramp to Stop 1: Coast to Stop 2: Fast-Stop 3: Alarm Only	0 to 3	1	A	A	A	A
F6-02	Selection of External Fault from Communication Option Board EF0 Detection	Selects the condition in which an EF0 fault is detected from a communication option board. Active only when a communication option board is installed and b1-01 or b1-02 = 3. 0: Always detected 1: Detected only during operation	0 to 1	0	A	A	A	A
F6-03	Stopping Method for External Fault from Communication Option Board EF0 Fault Action	Selects the stopping method for an external fault from a communication option board (EF0). Active only when a communication option board is installed and b1-01 or b1-02 = 3. 0: Ramp to Stop 1: Coast to Stop 2: Fast-Stop 3: Alarm Only	0 to 3	1	A	A	A	A
F6-04	Trace Sampling from Communications Option Board Trace Sample Tim	Sets the sample trace for the CP-916 option board.	0 to 60000	0	A	A	A	A
F6-05	Current Monitor Display Unit Selection Current Unit Sel	Selects the current monitor scaling when using a communication option board. 0: Displayed in Amps 1: 100%/8192 (12 bit binary number with 8192=100% Drive's rated current)	0 to 1	0	A	A	A	A
F6-06	Torque reference/torque limit selection from communications option Torq Ref/Lmt Sel	Selects torque reference/limit when using communications option board. 0: Disabled - Torque reference/limit from option board disabled 1: Enabled - Torque reference/limit from option board enabled.	0 to 1	1	-	-	-	A

◆Denotes that parameter can be changed when the Drive is running.

Table A.1 F7 Parameter List (Continued)

Parameter No.	Parameter Name Digital Operator Display	Description	Setting Range	Factory Setting	Control Method			
					V/F	V/F w/ PG	Open Loop Vector	Flux Vector
Digital Inputs								
H1-01	Multi-Function Digital Input Terminal S3 Function Selection Terminal S3 Sel	<p>Selects the function of terminals S3 to S8.</p> <p>0: 3-wire control FWD/REV selection for 3-wire sequence.</p> <p>1: Local/Remote Selection Closed = Local, Open = Remote.</p> <p>2: Option/Inv Selection Selects source of frequency reference and sequence. Closed = Option Card, Open = b1-01 & b1-02.</p> <p>3: Multi-Step Frequency Reference 1 Based on status of Multi-Step Reference 1 to 4 (d1-16).</p> <p>4: Multi-Step Frequency Reference 2 Based on status of Multi-Step Reference 1 to 4 (d1-16).</p> <p>5: Multi-Step Frequency Reference 3 Based on status of Multi-Step Reference 1 to 4 (d1-16).</p> <p>6: Jog Frequency Reference Closed = frequency reference from d1-17</p> <p>7: Accel/Decel Time Selection 1 Based on status of Accel/Decel Time Selection 1 and 2.</p> <p>8: External BaseBlock N.O. Closed = Output transistors forced off. Open = Normal operation.</p> <p>9: External BaseBlock N.C. Closed = Normal operation. Open = Output transistors forced off.</p> <p>A: Acc/Dec Ramp Hold Closed = Acceleration suspended and speed held.</p> <p>B: External Overheat Alarm (OH2) Closed = OH2 alarm.</p> <p>C: Terminal A2 Enable Closed = Terminal A2 is active. Open = Terminal A2 is disabled.</p> <p>D: V/F Control with PG Disabled Closed = Speed feedback control disabled.</p> <p>E: ASR Integral Reset Closed = Integral reset.</p> <p>F: Terminal Not Used Terminal closure has no effect.</p> <p>10: MOP Increase Closed = frequency reference increases. Open = frequency reference held. Must be set in conjunction with MOP Decrease and b1-01 must be set to 1.</p> <p>11: MOP Decrease Closed = frequency reference decreases. Open = frequency reference held. Must be set in conjunction with MOP Increase and b1-01 must be set to 1.</p> <p>12: Forward Jog Closed = Drive runs forward at frequency reference entered into parameter d1-17.</p> <p>13: Reverse Jog Closed = Drive runs in reverse at frequency reference entered into parameter d1-17.</p> <p>14: Fault Reset Closed = Resets the Drive after the fault and the run command have been removed.</p>	0 to 78	24	A	A	A	A
H1-02	Multi-Function Digital Input Terminal S4 Function Selection Terminal S4 Sel	<p>(Continued on following page).</p>	0 to 78	14	A	A	A	A

◆Denotes that parameter can be changed when the Drive is running.

Table A.1 F7 Parameter List (Continued)

Parameter No.	Parameter Name Digital Operator Display	Description	Setting Range	Factory Setting	Control Method			
					V/F	V/F w/ PG	Open Loop Vector	Flux Vector
H1-03	Multi-Function Digital Input Terminal S5 Function Selection Terminal S5 Sel	15: Fast-Stop N.O. Closed = Drive decelerates using C1-09, regardless of run command status. 16: Motor 2 Selection Closed = Motor 2 (E3-□□, E4-□□) Open = Motor 1 (A1-02, E1-□□, E2-□□) 17: Fast-Stop N.C. Closed = Normal operation Open = Drive decelerates using C1-09, regardless of run command status. 18: Timer Function Input for independent timer, controlled by b4-01 and b4-02. Used in conjunction with the multi-function digital output function H2-□□ = 12 “timer output”. 19: PID Disable Closed = Turns off the PID controller. 1A: Accel / Decel Time Selection 2 Based on status of Accel/Decel Time Selection 1 and 2. 1B: Program Lockout Closed = All parameter settings can be changed. Open = Only using monitor U1-01 can be changed. 1C: Trim Control Increase Closed = Increase frequency reference by value in d4-02. Open = Return to normal frequency reference. Not effective when Preset References are selected (Multi-step speed digital inputs are closed). Must be used in conjunction with Trim Ctrl Decrease. 1D: Trim Control Decrease Closed = Decrease frequency reference by value in d4-02. Open = Return to normal frequency reference. Not effective when Preset References are selected (Multi-step speed digital inputs are closed). Must be used in conjunction with Trim Ctrl Increase. 1E: Reference Sample Hold Analog frequency reference is sampled then held at time of input closure. 20: External Fault, Normally Open, Always Detected, Ramp To Stop 21: External Fault, Normally Closed, Always Detected, Ramp To Stop 22: External Fault, Normally Open, During Run, Ramp To Stop 23: External Fault, Normally Closed, During Run, Ramp To Stop 24: External Fault, Normally Open, Always Detected, Coast To Stop 25: External Fault, Normally Closed, Always Detected, Coast To Stop 26: External Fault, Normally Open, During Run, Coast To Stop 27: External Fault, Normally Closed, During Run, Coast To Stop 28: External Fault, Normally Open, Always Detected, Fast-Stop 29: External Fault, Normally Closed, Always Detected, Fast-Stop 2A: External Fault, Normally Open, During Run, Fast-Stop 2B: External Fault, Normally Closed, During Run, Fast-Stop 2C: External Fault, Normally Open, Always Detected, Alarm Only 2D: External Fault, Normally Closed, Always Detected, Alarm Only 2E: External Fault, Normally Open, During Run, Alarm Only 2F: External Fault, Normally Closed, During Run, Alarm Only	0 to 78	3: 2-wire 0: 3-wire	A	A	A	A
H1-04	Multi-Function Digital Input Terminal S6 Function Selection Terminal S6 Sel	20: External Fault, Normally Open, Always Detected, Ramp To Stop 21: External Fault, Normally Closed, Always Detected, Ramp To Stop 22: External Fault, Normally Open, During Run, Ramp To Stop 23: External Fault, Normally Closed, During Run, Ramp To Stop 24: External Fault, Normally Open, Always Detected, Coast To Stop 25: External Fault, Normally Closed, Always Detected, Coast To Stop 26: External Fault, Normally Open, During Run, Coast To Stop 27: External Fault, Normally Closed, During Run, Coast To Stop 28: External Fault, Normally Open, Always Detected, Fast-Stop 29: External Fault, Normally Closed, Always Detected, Fast-Stop 2A: External Fault, Normally Open, During Run, Fast-Stop 2B: External Fault, Normally Closed, During Run, Fast-Stop 2C: External Fault, Normally Open, Always Detected, Alarm Only 2D: External Fault, Normally Closed, Always Detected, Alarm Only 2E: External Fault, Normally Open, During Run, Alarm Only 2F: External Fault, Normally Closed, During Run, Alarm Only	0 to 78	4: 2-wire 3: 3-wire	A	A	A	A

(Continued on following page).

◆Denotes that parameter can be changed when the Drive is running.

Table A.1 F7 Parameter List (Continued)

Parameter No.	Parameter Name Digital Operator Display	Description	Setting Range	Factory Setting	Control Method			
					V/F	V/F w/ PG	Open Loop Vector	Flux Vector
Digital Inputs								
H1-05	Multi-Function Digital Input Terminal S7 Function Selection Terminal S7 Sel	30:PID integral reset Closed = Set integrator value to 0. 31: PID integral hold Closed = Hold integrator at its present level. 32: Multi-Step Reference 4 Based on the status of Multi-Step Reference 1 to 4 (d1-16). 34: PID Soft Starter Cancel Closed = b5-17 is ignored. 35: PID Input (Error) Polarity Change Closed = PID error signal polarity is reversed (1 to -1 or -1 to 1). 60: DC Injection Braking Closed = Apply DC injection current as set in parameter b2-02. 61: Speed Search 1 Closed = While a run command is given, Drive does a speed search starting at maximum frequency (E1-04). Speed search based on b3-01. 62: Speed Search 2 Closed = While a run command is given, Drive does a speed search starting at frequency reference. Speed search based on b3-01. 63: Field Weakening Command (Energy Savings) Closed = Field weakening control set for d6-01 and d6-02. 64: Speed Search 3 Closed = And a run command is given, Drive does a speed search starting at output frequency. Speed search based on b3-01. 65: Kinetic Energy Braking Ride-thru N.C. Closed = Normal operation Open = KEB ride-thru is enabled. 66: Kinetic Energy Braking Ride-thru N.O. Closed = KEB ride-thru is enabled. 67: Communications Test Mode Used to test Modbus RS-485/422 interface. 68: High Slip Braking Closed = Drive stops using High Slip Braking regardless of run command status. 69: Jog 2 Closed = Drive runs at frequency reference entered into parameter d1-17. Direction determined by fwd/rev input. 3-wire control Only. 6A: Drive Enable - Closed = Drive will accept run command. Open = Drive will not run. If running, Drive will stop per b1-03. 71: Speed / Torque Control Selection Closed = Torque control operation. Open = Speed control operation. 72: Zero-Servo Command Closed = Zero-Servo ON 77: ASR Gain Switch Closed = ASR proportional gain and integral time is set according to C5-03 and C5-04. 78: Polarity Reversing Command for External Torque Control Closed = Reverse polarity.	0 to 78	6: 2-wire 4: 3-wire	A	A	A	A
H1-06	Multi-Function Digital Input Terminal S8 Function Selection Terminal S8 Sel	62: Speed Search 2 Closed = While a run command is given, Drive does a speed search starting at frequency reference. Speed search based on b3-01. 63: Field Weakening Command (Energy Savings) Closed = Field weakening control set for d6-01 and d6-02. 64: Speed Search 3 Closed = And a run command is given, Drive does a speed search starting at output frequency. Speed search based on b3-01. 65: Kinetic Energy Braking Ride-thru N.C. Closed = Normal operation Open = KEB ride-thru is enabled. 66: Kinetic Energy Braking Ride-thru N.O. Closed = KEB ride-thru is enabled. 67: Communications Test Mode Used to test Modbus RS-485/422 interface. 68: High Slip Braking Closed = Drive stops using High Slip Braking regardless of run command status. 69: Jog 2 Closed = Drive runs at frequency reference entered into parameter d1-17. Direction determined by fwd/rev input. 3-wire control Only. 6A: Drive Enable - Closed = Drive will accept run command. Open = Drive will not run. If running, Drive will stop per b1-03. 71: Speed / Torque Control Selection Closed = Torque control operation. Open = Speed control operation. 72: Zero-Servo Command Closed = Zero-Servo ON 77: ASR Gain Switch Closed = ASR proportional gain and integral time is set according to C5-03 and C5-04. 78: Polarity Reversing Command for External Torque Control Closed = Reverse polarity.	0 to 78	8	A	A	A	A
♦Denotes that parameter can be changed when the Drive is running. Note: Some digital inputs are control method dependent.								

Table A.1 F7 Parameter List (Continued)

Parameter No.	Parameter Name Digital Operator Display	Description	Setting Range	Factory Setting	Control Method			
					V/F	V/F w/ PG	Open Loop Vector	Flux Vector
Digital Outputs								
H2-01	Terminal M1-M2 Function Selection Term M1-M2 Sel	<p>Selects the function of terminals M1 to M6.</p> <p>0: During RUN 1 Closed = When a run command is input or the Drive is outputting voltage.</p> <p>1: Zero Speed Closed = When Drive output frequency is less than minimum output frequency (E1-09).</p> <p>2: Fref/Fout Agree 1 Closed = When Drive output frequency equals the frequency reference +/- the hysteresis of L4-02.</p> <p>3: Fref/Set Agree 1 Closed = When the Drive output frequency and the frequency reference are equal to the value in L4-01 +/- the hysteresis of L4-02.</p> <p>4: Frequency Detection 1 Closed = When the Drive output frequency is less than or equal to the value in L4-01 with hysteresis determined by L4-02.</p> <p>5: Frequency Detection 2 Closed = When the Drive output frequency is greater than or equal to the value in L4-01, with hysteresis determined by L4-02.</p> <p>6: Inverter Ready Closed = When the Drive is powered up, not in a fault state, and in the DRIVE mode.</p> <p>7: DC Bus Undervoltage Closed = When the DC bus voltage falls below the UV trip level set in L2-05.</p> <p>8: Base Block 1 N.O. Closed = When the Drive is not outputting voltage.</p> <p>9: Option Reference Closed = When the frequency reference is coming from the Digital Operator.</p> <p>A: LOCAL/REMOTE Operation Closed = When the run command is coming from the Digital Operator.</p> <p>B: Torque Detection 1 N.O. Closed = When the output current/torque exceeds the torque value set in parameter L6-02 for more time than is set in parameter L6-03.</p> <p>C: Loss of Reference Closed = When the Drive has detected a loss of the analog frequency reference. Frequency reference is considered lost when it drops 90% in 0.4 seconds. Parameter L4-05 determines Drive reaction to a loss of frequency reference.</p> <p>D: Braking Resistor Fault Closed = When braking resistor or transistor is overheating or has faulted. Only active when L8-01 = 1.</p> <p>E: Fault Closed = When the Drive experiences a major fault.</p> <p>F: Not Used</p> <p>10: Minor Fault - Alarm Closed = When Drive experiences an alarm.</p> <p style="text-align: center;">(Continued on following page)</p>	0 to 38	0	A	A	A	A
♦Denotes that parameter can be changed when the Drive is running.								

Table A.1 F7 Parameter List (Continued)

Parameter No.	Parameter Name Digital Operator Display	Description	Setting Range	Factory Setting	Control Method			
					V/F	V/F w/ PG	Open Loop Vector	Flux Vector
H2-02	Terminal M3-M4 Function Selection Term M3-M4 Sel	11: Reset Command Active Closed = When the Drive receives a reset command from a digital input terminal or serial communication. 12: Timer Output Output for independent timer, controlled by b4-01 and b4-02. Used in conjunction with the digital input H1-□□ = 18 “timer function”. 13: Fref/Fout Agree 2 Closed = When Drive output frequency equals the frequency reference +/- the hysteresis of L4-04. 14: Fref/Set Agree 2 Closed = When the Drive output frequency and the frequency reference are equal to the value in L4-03 +/- the hysteresis of L4-04. 15: Frequency Detection 3 Closed = When the Drive output frequency is less than or equal to the value in L4-03 with the hysteresis determined by L4-04. 16: Frequency Detection 4 Closed = When the Drive output speed is greater than or equal to the value in L4-03, with the hysteresis determined by L4-04. 17: Torque Detection 1 N.C. Open = When the output current/torque exceeds the value set in parameter L6-02 for more time than is set in parameter L6-03. 18: Torque Detection 2 N.O. Closed = When the output current/torque exceeds the value set in parameter L6-05 for more time than is set in parameter L6-06. 19: Torque Detection 2 N.C. Open = when the output current/torque exceeds the value set in parameter L6-05 for more time than is set in parameter L6-06.	0 to 38	1	A	A	A	A
H2-03	Terminal M5-M6 Function Selection Term M5-M6 Sel	1A: Reverse Direction Closed = When the Drive is running in the reverse direction. 1B: Baseblock 2 N.C. Open = When Drive is not outputting voltage. 1C: Motor 2 Selection Closed = When motor 2 is selected by multi-function input “motor 2 selection”. 1D: Regenerating Closed = When in regenerating mode. 1E: Restart Enabled Closed = When the Drive is performing an automatic restart attempt. Automatic restart is configured by parameter L5-01. 1F: Overload (OL1) Closed = When OL1 function is at 90% of its trip point or greater. 20: OH Prealarm Closed = When the Drive’s heatsink temperature exceeds the setting of parameter L8-02. 30: During Torque Limit (when in speed control) Closed = When in torque limit. 31: During Speed Limit Closed = When in speed limit. 32: During Speed Limit (when in torque control) Closed = When motor frequency is at the speed limit value when running in torque control. 33: Zero-Servo Complete Closed = When Zero Servo is complete within the b9-02 zero servo completion width. 37: During Run 2 Closed = When Drive is operating (except during baseblock or DC braking). 38: Drive Enable Closed = When the Drive enable input is active.	0 to 38	2	A	A	A	A

◆Denotes that parameter can be changed when the Drive is running.
 Note: Some digital outputs are control method dependent.

Table A.1 F7 Parameter List (Continued)

Parameter No.	Parameter Name Digital Operator Display	Description	Setting Range	Factory Setting	Control Method			
					V/F	V/F w/ PG	Open Loop Vector	Flux Vector
Analog Inputs								
H3-01	Terminal A1 Signal Level Selection Term A1 Lvl Sel	Sets the signal level of terminal A1. 0: 0 to 10Vdc 1: -10 to +10Vdc	0 to 1	0	A	A	A	A
H3-02 ◆	Terminal A1 Gain Setting Terminal A1 Gain	Sets the output level when 10V is input, as a percentage of the maximum output frequency (E1-04).	0.0 to 1000.0	100.0%	A	A	A	A
H3-03 ◆	Terminal A1 Bias Setting Terminal A1 Bias	Sets the output level when 0V is input, as a percentage of the maximum output frequency (E1-04).	-100.0 to +100.0	0.0%	A	A	A	A
H3-04	Terminal A3 Signal Level Selection Term A3 Signal	Sets the signal level of terminal A3. 0: 0 to 10Vdc 1: -10 to +10Vdc	0 to 1	0	A	A	A	A
H3-05	Terminal A3 Function Selection Terminal A3 Sel	<p>Selects the function of terminal A3.</p> <p>0: Frequency Bias 100% = Maximum output frequency (E1-04)</p> <p>1: Frequency Reference Gain (FGAIN) 100% = Frequency reference command value A1 Total gain = Internal gain (H3-02) x FGAIN</p> <p>2: Aux Frequency Reference 1 Used in conjunction with multi-function inputs "multi-step frequency reference 1-4" (d1-16). 100% = Maximum output frequency (E1-04)</p> <p>3: Aux Frequency Reference 2 Used in conjunction with multi-function inputs "multi-step frequency reference 1-4" (d1-16). 100% = Maximum output frequency (E1-04)</p> <p>4: Output Voltage Bias 100% = Motor rated voltage (E1-05). Voltage boost after V/F pattern.</p> <p>5: Accel / Decel Time Coefficient 100% = Active accel / decel time (C1-01 thru C1-08)</p> <p>6: DC Injection Braking Current 100% = Drive rated current. Parameter b2-02 is disabled.</p> <p>7: Overtorque / Undertorque Detection Level Used for multi-function digital output for "overtorque/undertorque". 100% = motor rated torque (OLV, FV) or Drive rated current (V/F, V/F w/PG). Internal overtorque detection level (C6-02) disabled.</p> <p>8: Stall Prevention Level During Run 100% = L3-06.</p> <p>9: Frequency Reference Lower Limit 100% = Maximum output frequency (E1-04). Either d2-02 setting or A3 input level, whichever is greater, becomes effective.</p> <p>A: Jump Frequency 4 100% = Maximum output frequency (E1-04).</p> <p>B: PID Feedback 100% = Maximum output frequency (E1-04).</p> <p>C: PID Set Point 100% = Maximum output frequency (E1-04). Frequency reference no longer acts as a PID setpoint.</p> <p>D: Frequency Reference Bias 2 (FBIAS2) 100% = Maximum output frequency (E1-04). Total bias = Internal bias (H3-03) + FBIAS (H3-07) + A3 input level</p> <p>E: Motor Temperature See parameters L1-03 & L1-04.</p> <p>10: FWD Torque Limit (Quadrant 1) 100% = Motor rated torque.</p> <p>11: REV Torque Limit (Quadrant 3) 100% = Motor rated torque.</p> <p>12: Regenerative Torque Limit (Quadrants 2 and 4) 100% = Motor rated torque.</p> <p>13: Torque Reference (in Torque Control); Torque Limit (in Speed Control) (Quadrants 1, 2, 3, 4) 100% = Motor rated torque.</p> <p>14: Torque Compensation 100% = Motor rated torque.</p> <p>15: FWD / REV Torque Limit (Quadrants 1 and 3) 100% = Motor rated torque.</p> <p>1F: Not Used</p>	0 to 1F	2	A	A	A	A

◆Denotes that parameter can be changed when the Drive is running. Note: Some analog inputs are control method dependent.

Table A.1 F7 Parameter List (Continued)

Parameter No.	Parameter Name Digital Operator Display	Description	Setting Range	Factory Setting	Control Method			
					V/F	V/F w/ PG	Open Loop Vector	Flux Vector
H3-06 ◆	Terminal A3 Gain Setting Terminal A3 Gain	Sets the output level when 10V is input.	0.0 to 1000.0	100.0%	A	A	A	A
H3-07 ◆	Terminal A3 Bias Setting Terminal A3 Bias	Sets the frequency reference when 0V is input.	-100.0 to +100.0	0.0%	A	A	A	A
H3-08	Terminal A2 Signal Level Selection Term A2 Signal	Selects the signal level of terminal A2. 0: 0 to 10Vdc (switch S1-2 must be in the OFF position). 1: -10 to +10Vdc (switch S1-2 must be in the OFF position). 2: 4 to 20mA (switch S1-2 must be in the ON position)	0 to 2	2	A	A	A	A
H3-09	Terminal A2 Function Selection Terminal A2 Sel	Selects the function of terminal A2. Same choices as Terminal A3 Function Selection (H3-05).	0 to 1F	0	A	A	A	A
H3-10 ◆	Terminal A2 Gain Setting Terminal A2 Gain	Sets the output level when 10V is input.	0.0 to 1000.0	100.0%	A	A	A	A
H3-11 ◆	Terminal A2 Bias Setting Terminal A2 Bias	Sets the output level when 0V is input.	-100.0 to +100.0	0.0%	A	A	A	A
H3-12	Analog Input Filter Time Constant Filter Avg Time	This parameter adjusts the filter on all 3 analog inputs. Increase to add stability, decrease to improve response.	0.00 to 2.00	0.03sec	A	A	A	A

◆Denotes that parameter can be changed when the Drive is running.

Table A.1 F7 Parameter List (Continued)

Parameter No.	Parameter Name Digital Operator Display	Description	Setting Range	Factory Setting	Control Method			
					V/F	V/F w/ PG	Open Loop Vector	Flux Vector
Analog Outputs								
H4-01	Terminal FM Monitor Selection Terminal FM Sel	Selects which monitor will be output on terminals FM and FC. 1: Frequency Reference 100% = Maximum output frequency E1-04. 2: Output Frequency 100% = Maximum output frequency E1-04. 3: Output Current 100% = Drive rated current. 5: Motor Speed 100% = Maximum output frequency E1-04. 6: Output Voltage 100% = 200/400Vac depending on Drive voltage rating. 7: DC Bus Voltage 100% = 400/800Vdc depending on Drive voltage rating. 8: Output kWatts 100% = Drive rated power. 9: Torque Reference 100% = Motor rated torque. 15: Terminal A1 Input Level 100% = 10Vdc 16: Terminal A2 Input Level 100% = 10Vdc or 20mA 17: Terminal A3 Input Level 100% = 10Vdc 18: Motor Secondary Current 100% = Motor rated secondary current. 19: Motor Excitation Current 100% = Motor rated magnetizing current. 20: SFS Output 100% = Maximum output frequency E1-04. 21: ASR Input 100% = Maximum output frequency E1-04. 22: ASR Output 100% = Maximum output frequency E1-04. 24: PID Feedback 100% = Maximum output frequency E1-04. 26: Output Voltage Reference Vq 100% = E1-05, default 240V or 480V. 27: Output Voltage Reference Vd 100% = E1-05, default 240V or 480V. 31: Not Used 32: ACR q Output (100% = Motor rated secondary current) 33: ACR d Output (100% = Motor rated magnetizing current) 36: PID Input 100% = Maximum output frequency E1-04. 37: PID Output 100% = Maximum output frequency E1-04. 38: PID Setpoint 100% = Maximum output frequency E1-04. 44: ASR Output Without Filter 45: Feedforward Control Output 100% = Motor rated secondary current.	45	2	A	A	A	A
H4-02 ◆	Terminal FM Gain Setting Terminal FM Gain	Sets terminal FM output level when selected monitor is at 100%.	0.0 to 1000.0	100.0%	Q	Q	Q	Q
H4-03 ◆	Terminal FM Bias Setting Terminal FM Bias	Sets terminal FM output level when selected monitor is at 0%.	-110.0 to 110.0	0.0%	A	A	A	A
H4-04	Terminal AM Monitor Selection Terminal AM Sel	Selects which monitor will be the output on terminals AM and FC. Same function choices as H4-01.	1 to 53	3	A	A	A	A
H4-05 ◆	Terminal AM Gain Setting Terminal AM Gain	Sets terminal AM output voltage (in percent of 10Vdc) when selected monitor is at 100% output.	0.0 to 1000.0	50.0%	Q	Q	Q	Q
H4-06 ◆	Terminal AM Bias Setting Terminal AM Bias	Sets terminal AM output voltage (in percent of 10Vdc) when selected monitor is at 0% output.	-110.0 to 110.0	0.0%	A	A	A	A
H4-07	Terminal FM Signal Level Selection AO Level Select 1	Selects the signal level of terminal FM. 0: 0 to 10Vdc 1: -10 to +10Vdc 2: 4 to 20mA*	0 or 2	0	A	A	A	A
H4-08	Terminal AM Signal Level Selection AO Level Select 2	Selects the signal level of terminal AM. 0: 0 to 10Vdc 1: -10 to +10Vdc 2: 4 to 20mA*	0 or 2	0	A	A	A	A

◆Denotes that parameter can be changed when the Drive is running.

Note: Some analog outputs are control method dependent.

Table A.1 F7 Parameter List (Continued)

Parameter No.	Parameter Name Digital Operator Display	Description	Setting Range	Factory Setting	Control Method			
					V/F	V/F w/ PG	Open Loop Vector	Flux Vector
Serial Communications Setup								
H5-01	Drive Node Address Serial Comm Adr	Selects Drive station node number (address) for Modbus terminals R+, R-, S+, S-. The Drive's power must be cycled for the setting to take effect.	0 to 20 Hex	1F	A	A	A	A
H5-02	Communication Speed Selection Serial Baud Rate	Selects the baud rate for Modbus terminals R+, R-, S+ and S-. The Drive's power must be cycled for the setting to take effect. 0: 1200 bps 1: 2400 bps 2: 4800 bps 3: 9600 bps 4: 19200 bps	0 to 4	3	A	A	A	A
H5-03	Communication Parity Selection Serial Com Sel	Selects the communication parity for Modbus terminals R+, R-, S+ and S-. The Drive's power must be cycled for the setting to take effect. 0: No Parity 1: Even Parity 2: Odd Parity	0 to 2	0	A	A	A	A
H5-04	Stopping Method After Communication Error Serial Fault Sel	Selects the stopping method when a communication timeout fault (CE) is detected. 0: Ramp to Stop 1: Coast to Stop 2: Fast-Stop 3: Alarm Only	0 to 3	3	A	A	A	A
H5-05	Communication Fault Detection Selection Serial Flt Dctt	Enables or disables the communications timeout fault (CE). 0: Disabled - A communication loss will not cause a communication fault. 1: Enabled - If communication is lost for more than 2 seconds, a CE fault will occur.	0 to 1	1	A	A	A	A
H5-06	Drive Transmit Wait Time Transmit WaitTIM	Set the delay time from when the Drive receives data to when the Drive sends data.	5 to 65	5ms	A	A	A	A
H5-07	RTS Control Selection RTS Control Sel	Enables or disables "request to send" (RTS) control: 0: Disabled - RTS is always on 1: Enabled - RTS turns on only when sending	0 to 1	1	A	A	A	A
Pulse I/O Setup								
H6-01	Terminal RP Pulse Train Input Function Selection Pulse Input Sel	Selects the function of pulse train terminal RP. 0: Frequency reference 1: PID feedback value 2: PID setpoint value	0 to 2	0	A	A	A	A
H6-02 ◆	Pulse Train Input Scaling Pulse In Scaling	Sets the number of pulses (in Hz) that is equal to the maximum output frequency E1-04.	1000 to 32000	1440Hz	A	A	A	A
H6-03 ◆	Pulse Train Input Gain Pulse Input Gain	Sets the output level when the pulse train input is at 100% as a percentage of maximum output frequency E1-04.	0.0 to 1000.0	100.0%	A	A	A	A
H6-04 ◆	Pulse Train Input Bias Pulse Input Bias	Sets the output level when the pulse train input is 0Hz as a percentage of maximum output frequency E1-04.	-100.0 to 100.0	0.0%	A	A	A	A
H6-05 ◆	Pulse Train Input Filter Time Pulse In Filter	Sets the pulse train input filter time constant in seconds.	0.00 to 2.00	0.10sec	A	A	A	A
H6-06 ◆	Terminal MP Pulse Train Monitor Selection Pulse Moni Sel	Select the pulse train monitor output terminal MP function (value of the □□ part of U1-□□). See Table A2 for the list of U1 monitors.	1, 2, 5, 20, 24, 31, 36	2	A	A	A	A
H6-07 ◆	Pulse Train Monitor Scaling Pulse Moni Scale	Sets the number of output pulses when the monitor is 100% (in Hz). Set H6-06 to 2, and H6-07 to 0, to make the pulse train monitor output synchronous to the output frequency.	0 to 32000	1440Hz	A	A	A	A

◆ Denotes that parameter can be changed when the Drive is running.

Table A.1 F7 Parameter List (Continued)

Parameter No.	Parameter Name Digital Operator Display	Description	Setting Range	Factory Setting	Control Method			
					V/F	V/F w/ PG	Open Loop Vector	Flux Vector
Motor Overload								
L1-01	Motor Overload Protection Selection MOL Fault Select	Sets the motor thermal overload protection (OL1) based on the cooling capacity of the motor. 0: Disabled 1: Standard Fan Cooled (< 10:1 motor) 2: Standard Blower Cooled (≥ 10:1 motor) 3: Vector Motor (≤ 1000:1 motor)	0 to 3	1	Q	Q	Q	Q
L1-02	Motor Overload Protection Time MOL Time Const	Sets the motor thermal overload protection (OL1) time. A larger L1-02 time will increase the time before an OL1 fault will occur.	0.1 to 20.0	8.0min	A	A	A	A
L1-03	Motor Overheat Alarm Operation Selection Mtr OH Alarm Sel	Sets operation selection when the motor temperature analog input (H3-09 = E) exceeds the OH3 alarm level (1.17V) 0: Ramp to Stop 1: Coast to Stop 2: Fast-Stop 3: Alarm Only	0 to 3	3	A	A	A	A
L1-04	Motor Overheat Fault Operation Selection Mtr OH Fault Sel	Sets stopping method when the motor temperature analog input (H3-09 = E) exceeds the OH4 fault level (2.34V). 0: Ramp to Stop 1: Coast to Stop 2: Fast-Stop	0 to 2	1	A	A	A	A
L1-05	Motor Temperature Input Filter Time Mtr Temp Filter	This parameter adjusts the filter on the motor temperature analog input (H3-09 = E). Increase to add stability, decrease to improve response.	0.00 to 10.00	0.20sec	A	A	A	A
Power Loss Ridethru								
L2-01	Momentary Power Loss Detection Selection PwrL Selection	Enables and disables the momentary power loss function. 0: Disabled - Drive trips on (UV1) fault when power is lost. 1: Power Loss Ride Thru Time - Drive will restart if power returns within the time set in L2-02.* 2: CPU Power Active - Drive will restart if power returns prior to control power supply shut down.* * In order for a restart to occur, the run command must be maintained throughout the ride thru period.	0 to 2	0	A	A	A	A
L2-02	Momentary Power Loss Ride-thru Time PwrL Ridethru t	Sets the power loss ride-thru time. This value is dependent on the capacity of the Drive. Only effective when L2-01 = 1.	0.0 to 25.5sec	Varies by kVA	A	A	A	A
L2-03	Momentary Power Loss Minimum Base Block Time PwrL Baseblock t	Sets the minimum time to wait to allow the residual motor voltage to decay before the Drive output turns back on during power loss ride thru. After a power loss, if L2-03 is greater than L2-02, operation resumes after the time set in L2-03.	0.1 to 5.0sec	Varies by kVA	A	A	A	A
L2-04	Momentary Power Loss Voltage Recovery Ramp Time PwrL V/F Ramp t	Sets the time it takes the output voltage to return to the preset V/F pattern after speed search (current detection mode) is complete.	0.0 to 5.0sec	Varies by kVA	A	A	A	A
L2-05	Undervoltage Detection Level PUV Det Level	Sets the Drive's DC Bus undervoltage trip level. If this is set lower than the factory setting, additional AC input reactance or DC bus reactance may be necessary. Consult the factory before changing this parameter setting.	150 to 210	190 Vdc	A	A	A	A
L2-06	KEB Deceleration Rate KEB Decel Time	Sets the time required to decelerate to zero speed when a KEB command is input from a multi-function input.	0.0 to 200.0	0.0sec	A	A	A	A
L2-07	Momentary Recovery Time UV Return Time	Set the time (in seconds) to accelerate to the set speed after recovery from a momentary power loss. If setting = 0.0, then active acceleration time is used instead.	0.0 to 25.5	0.0sec	A	A	A	A
L2-08	Frequency Reduction Gain at KEB Start KEB Frequency	Sets the percentage of output frequency reduction at the beginning of deceleration when a KEB command is input from multi-function input. Reduction = slip frequency before KEB operation × L2-08 × 2	0 to 300	100%	A	A	A	A

◆Denotes that parameter can be changed when the Drive is running.

Table A.1 F7 Parameter List (Continued)

Parameter No.	Parameter Name Digital Operator Display	Description	Setting Range	Factory Setting	Control Method			
					V/F	V/F w/ PG	Open Loop Vector	Flux Vector
Stall Prevention								
L3-01	Stall Prevention Selection During Accel StallP Accel Sel	Selects the stall prevention method used to prevent excessive current during acceleration. 0: Disabled - Motor accelerates at active acceleration rate. The motor may stall if load is too heavy or accel time is too short. 1: General Purpose - When output current exceeds L3-02 level, acceleration stops. Acceleration will continue when the output current level falls below the L3-02 level. 2: Intelligent - The active acceleration rate is ignored. Acceleration is completed in the shortest amount of time without exceeding the current value set in L3-02.	0 to 2	1	A	A	A	-
L3-02	Stall Prevention Level During Acceleration StallP Accel Lvl	This function is enabled when L3-01 is "1" or "2". Drive rated current is 100%. Decrease the set value if stalling or excessive current occurs with factory setting.	0 to 200	Varies by Duty Rating*	A	A	A	-
L3-03	Stall Prevention Limit During Acceleration StallP CHP Lvl	Sets the lower limit for stall prevention during acceleration, as a percentage of the Drive's rated current, when operation is in the frequency range above E1-06 (constant power region).	0 to 100	50%	A	A	A	-
L3-04	Stall Prevention Selection During Deceleration StallP Decel Sel	When using a braking resistor, use setting "0". Setting "3" is used in specific applications. 0: Disabled - The Drive decelerates at the active deceleration rate. If the load is too large or the deceleration time is too short, an OV fault may occur. 1: General Purpose - The Drive decelerates at the active deceleration rate, but if the main circuit DC bus voltage reaches the stall prevention level (380/760Vdc), deceleration will stop. Deceleration will continue once the DC bus level drops below the stall prevention level. 2: Intelligent - The active deceleration rate is ignored and the Drive decelerates as fast as possible w/o hitting OV fault level. Range: C1-02 / 10. 3: Stall Prevention w/ Braking Resistor - Stall prevention during deceleration is enabled in coordination with dynamic braking.	0 to 3	1	Q	Q	Q	Q
L3-05	Stall Prevention Selection During Running StallP Run Sel	Selects the stall prevention method to use to prevent Drive faults during run. 0: Disabled - Drive runs a set frequency. A heavy load may cause the Drive to trip on an OC or OL fault. 1: Decel Time 1 - In order to avoid stalling during heavy loading, the Drive will decelerate at Decel time 1 (C1-02) if the output current exceeds the level set by L3-06. Once the current level drops below the L3-06 level, the Drive will accelerate back to its frequency reference at the active acceleration rate. 2: Decel Time 2 - Same as setting 1 except the Drive decelerates at Decel Time 2 (C1-04). When output frequency is 6Hz or less, stall prevention during running is disabled regardless of L3-05 setting.	0 to 2	1	A	A	-	-
L3-06	Stall Prevention Level During Running StallP Run Level	This parameter is enabled when L3-05 is set to "1" or "2". Drive rated current is set as 100%. Decrease the set value if stalling or excessive current occurs with factory setting.	30 to 200	Varies by Duty Rating*	A	A	-	-
L3-11	OV Suppression Function Selection OV Inhibit Sel	Enables or disables OV suppression function, which allows the Drive to change the output frequency as the load changes, to prevent OV fault. 0: Disabled 1: Enabled	0 to 1	0	-	-	A	A
L3-12	OV Suppression Function Voltage Level OV Inhbt VoltLvl	Sets the DC bus voltage level at which the OV suppression function is active.	350 to 390 (240V) 700 to 780 (480V)	380V or 760V	-	-	A	A

◆ Denotes that parameter can be changed when the Drive is running.

* For Heavy Duty (HD) Rating: Factory Setting=150%. For Normal Duty (ND) Rating: Factory Setting=120%.

Table A.1 F7 Parameter List (Continued)

Parameter No.	Parameter Name Digital Operator Display	Description	Setting Range	Factory Setting	Control Method			
					V/F	V/F w/ PG	Open Loop Vector	Flux Vector
Reference Detection								
L4-01	Speed Agreement Detection Level Spd Agree Level	These parameters configure the multi-function output (H2-□□) settings "Fref/Fout agree 1", "Fref/Set agree 1", "Frequency detection 1," and "Frequency detection 2". Parameter L4-01 sets the level while parameter L4-02 sets the hysteresis for the speed detection output function.	Varies by Duty Rating*1	0.0Hz	A	A	A	A
L4-02	Speed Agreement Detection Width Spd Agree Width		0.0 to 20.0	2.0Hz	A	A	A	A
L4-03	Speed Agreement Detection Level (+/-) Spd Agree Lvl +/-	These parameters configure the multi-function output (H2-□□) settings "Fref/Fout agree 2", "Fref/Set agree 2", "Frequency detection 3," or "Frequency detection 4". Parameter L4-03 sets the level while parameter L4-04 sets the hysteresis for the speed detection output function.	Varies by Duty Rating*2	0.0Hz	A	A	A	A
L4-04	Speed Agreement Detection Width (+/-) Spd Agree Wdth +/-		0.0 to 20.0	2.0Hz	A	A	A	A
L4-05	Frequency Reference Loss Detection Selection Ref Loss Sel	Determines how the Drive will react when the frequency reference is lost. The frequency reference is considered lost when reference drops 90% or more of its current value in less than 400ms. 0: Stop - Drive will stop. 1: Run at L4-06 PrevRef - Drive will run at the percentage set in L4-06 of the frequency reference level at the time frequency reference was lost.	0 to 1	0	A	A	A	A
L4-06	Frequency Reference Level at Loss Frequency Fref at Floss	If the frequency reference loss function is enabled (L4-05=1) and frequency reference is lost, the Drive will run at a reduced frequency reference determined by the following formula: Fref = Fref at time of loss * L4-06.	0 to 100.0	80.0%	A	A	A	A
Fault Restart								
L5-01	Number of Auto Restart Attempts Num of Restarts	Sets the counter for the number of times the Drive will perform an automatic restart on the following faults: GF, LF, OC, OV, PF, PUF, RH, RR, OL1, OL2, OL3, OL4, UV1. Auto restart will check to see if the fault has cleared every 5ms. When no fault is present, the Drive will attempt an auto restart. If the Drive faults after an auto restart attempt, the counter is incremented. When the Drive operates without fault for 10 minutes, the counter will reset to the value set in L5-01.	0 to 10	0	A	A	A	A
L5-02	Auto Restart Operation Selection Restart Sel	Determines if the fault contact activates during an automatic restart attempt. 0: No Fault Relay - fault contact will not activate during an automatic restart attempt. 1: Fault Relay Active - fault contact will activate during an automatic restart attempt.	0 to 1	0	A	A	A	A
<p>◆Denotes that parameter can be changed when the Drive is running. *1 For Heavy Duty (HD) Rating: Setting Range=0.0 to 300.0. For Normal Duty (ND) Rating: Setting Range=0.0 to 400.0. *2 For Heavy Duty (HD) Rating: Setting Range= -300.0 to 300.0. For Normal Duty (ND) Rating: Setting Range= -400.0 to 400.0.</p>								

Table A.1 F7 Parameter List (Continued)

Parameter No.	Parameter Name Digital Operator Display	Description	Setting Range	Factory Setting	Control Method			
					V/F	V/F w/ PG	Open Loop Vector	Flux Vector
Torque Detection								
L6-01	Torque Detection Selection 1 Torq Det 1 Sel	Determines the Drive's response to an Overtorque/Undertorque condition. Overtorque and Undertorque are determined by the settings in parameters L6-02 and L6-03. The multi-function output settings "B" and "17" in the H2-□□ parameter group are also active if programmed. 0: Disabled 1: OL3 at Speed Agree - Alarm (Overtorque Detection only active during Speed Agree and Operation continues after detection). 2: OL3 at RUN - Alarm (Overtorque Detection is always active and operation continues after detection). 3: OL3 at Speed Agree - Fault (Overtorque Detection only active during Speed Agree and Drive output will shut down on an OL3 fault). 4: OL3 at RUN - Fault (Overtorque Detection is always active and Drive output will shut down on an OL3 fault). 5: UL3 at Speed Agree - Alarm (Undertorque Detection is only active during Speed Agree and operation continues after detection). 6: UL3 at RUN - Alarm (Undertorque Detection is always active and operation continues after detection). 7: UL3 at Speed Agree - Fault (Undertorque Detection only active during Speed Agree and Drive output will shut down on an OL3 fault). 8: UL3 at RUN - Fault (Undertorque Detection is always active and Drive output will shut down on an OL3 fault).	0 to 8	0	A	A	A	A
L6-02	Torque Detection Level 1 Torq Det 1 Lvl	Sets the Overtorque/Undertorque detection level as a percentage of Drive rated current or torque for torque detection 1. Current detection for A1-02 = 0 or 1. Torque detection for A1-02 = 2 or 3.	0 to 300	150%	A	A	A	A
L6-03	Torque Detection Time 1 Torq Det 1 Time	Sets the length of time an Overtorque/Undertorque condition must exist before torque detection 1 recognized by the Drive.	0.0 to 10.0	0.1sec	A	A	A	A
L6-04	Torque Detection Selection 2 Torq Det 2 Sel	Determines the Drive's response to an Overtorque/Undertorque condition. Overtorque and Undertorque are determined by the settings in parameters L6-05 and L6-06. The multi-function output settings "18" and "19" in the H2-□□ parameter group are also active if programmed. 0: Disabled 1: OL4 at Speed Agree - Alarm (Overtorque Detection only active during Speed Agree and Operation continues after detection). 2: OL4 at RUN - Alarm (Overtorque Detection is always active and operation continues after detection). 3: OL4 at Speed Agree - Fault (Overtorque Detection only active during Speed Agree and Drive output will shut down on an OL4 fault). 4: OL4 at RUN - Fault (Overtorque Detection is always active and Drive output will shut down on an OL4 fault). 5: UL4 at Speed Agree - Alarm (Undertorque Detection is only active during Speed Agree and operation continues after detection). 6: UL4 at RUN - Alarm (Undertorque Detection is always active and operation continues after detection). 7: UL4 at Speed Agree - Fault (Undertorque Detection only active during Speed Agree and Drive output will shut down on an OL4 fault). 8: UL4 at RUN - Fault (Undertorque Detection is always active and Drive output will shut down on an OL4 fault).	0 to 8	0	A	A	A	A
L6-05	Torque Detection Level 2 Torq Det 2 Lvl	Sets the Overtorque/Undertorque detection level as a percentage of Drive rated current or torque for torque detection 2. Current detection for A1-02 = 0 or 1. Torque detection for A1-02 = 2 or 3.	0 to 300	150%	A	A	A	A
L6-06	Torque Detection Time 2 Torq Det 2 Time	Sets the length of time an Overtorque/Undertorque condition must exist before torque detection 2 is recognized by the Drive.	0.0 to 10.0	0.1sec	A	A	A	A

◆ Denotes that parameter can be changed when the Drive is running.

Table A.1 F7 Parameter List (Continued)

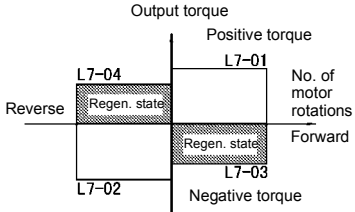
Parameter No.	Parameter Name Digital Operator Display	Description	Setting Range	Factory Setting	Control Method			
					V/F	V/F w/ PG	Open Loop Vector	Flux Vector
Torque Limit								
L7-01	Forward Torque Limit Torq Limit Fwd	Sets the torque limit value as a percentage of the motor rated torque. Four individual quadrants can be set. 	0 to 300	200%	-	-	A	A
L7-02	Reverse Torque Limit Torq Limit Rev		0 to 300	200%	-	-	A	A
L7-03	Forward Regenerative Torque Limit Torq Lmt Fwd Rgn		0 to 300	200%	-	-	A	A
L7-04	Reverse Regenerative Torque Limit Torq Lmt Rev Rgn		0 to 300	200%	-	-	A	A
Hardware Protection								
L8-01	Internal Dynamic Braking Resistor Protection Selection DB Resistor Prot	Selects the DB protection only when using 3% duty cycle heatsink mount Yaskawa braking resistor. This parameter does not enable or disable the DB function of the Drive. 0: Not Provided 1: Provided	0 to 1	0	A	A	A	A
L8-02	Overheat Alarm Level OH Pre-Alarm Lvl	When the cooling fin temperature exceeds the value set in this parameter, an overheat alarm (OH) will occur.	50 to 130	95°C	A	A	A	A
L8-03	Overheat Pre-Alarm Operation Selection OH Pre-Alarm Sel	Selects the Drive operation upon an OH pre-alarm detection. 0: Ramp to Stop 1: Coast to Stop 2: Fast-Stop 3: Alarm Only	0 to 3	3	A	A	A	A
L8-05	Input Phase Loss Protection Selection Ph Loss In Sel	Selects the detection of input current phase loss, power supply voltage imbalance, or main circuit electrostatic capacitor deterioration. 0: Disabled 1: Enabled	0 to 1	1	A	A	A	A
L8-07	Output Phase Loss Protection Ph Loss Out Sel	Selects the detection of output current open-phase. When applied motor capacity is too small for Drive capacity, output phase loss may be detected inadvertently. In this case, set to 0. 0: Disabled 1: 1-phase Loss Detection 2: 2/3-phase Loss Detection	0 to 1	1	A	A	A	A
L8-09	Output Ground Fault Detection Selection Ground Fault Sel	Enables and disables the Drive's output ground fault detection. 0: Disabled 1: Enabled	0 to 1	1	A	A	A	A
L8-10	Heatsink Cooling Fan Operation Selection Fan On/Off Sel	Controls the heatsink cooling fan operation. 0: Fan On-Run Mode - Fan will operate only when the Drive is running and for L8-11 seconds after RUN is removed. 1: Fan Always On - Cooling fan operates whenever the Drive is powered up.)	0 to 1	0	A	A	A	A
L8-11	Heatsink Cooling Fan Operation Delay Time Fan Delay Time	This parameter sets the delay time for the cooling fan turn off after the run command is removed when L8-10 = 0.	0 to 300	60sec	A	A	A	A
L8-12	Ambient Temperature Setting Ambient Temp	When the Drive is installed in an ambient temperature exceeding its rating, the Drive overload (OL2) protection level is adjusted.	45 to 60	45°C	A	A	A	A

◆Denotes that parameter can be changed when the Drive is running.

Table A.1 F7 Parameter List (Continued)

Parameter No.	Parameter Name Digital Operator Display	Description	Setting Range	Factory Setting	Control Method			
					V/F	V/F w/ PG	Open Loop Vector	Flux Vector
L8-15	OL2 Characteristic Selection at Low Speeds OL2 Sel @ L-Spd	This parameter assists in protecting the output transistors from overheating when output current is high and output frequency is low (6Hz and less). 0: Disabled 1: Enabled (L8-18 is active)	0 to 1	0	A	A	A	A
L8-18	Soft CLA Selection Soft CLA Sel	Enables and disables the software current limit function. Consult the factory before disabling. 0: Disabled 1: Enabled	0 to 1	1	A	A	A	A
Hunting Prevention								
n1-01	Hunting Prevention Selection Hunt Prev Select	If the motor vibrates while lightly loaded, hunting prevention may reduce the vibration. 0: Disabled 1: Enabled	0 to 1	1	A	A	-	-
n1-02	Hunting Prevention Gain Setting Hunt Prev Gain	Sets the gain for the Hunting Prevention Function. If the motor vibrates while lightly loaded and n1-01=1, increase the gain by 0.1 until vibration ceases. If the motor stalls while n1-01=1, decrease the gain by 0.1 until the stalling ceases.	0.00 to 2.50	1.00	A	A	-	-
AFR Tuning								
n2-01	Speed Feedback Detection Control (AFR) Gain AFR Gain	Sets the internal speed feedback detection control gain in the automatic frequency regulator (AFR). Normally, there is no need to change this setting. Adjust this parameter as follows: • If hunting occurs, increase the set value. • If response is low, decrease the set value. Adjust the setting by 0.05 units at a time, while checking the response.	0.00 to 10.00	1.00	-	-	A	-
n2-02	Speed Feedback Detection Control (AFR) Time Constant AFR Time	Sets the time constant to control the rate of change in the speed feedback detection control.	0 to 2000	50ms	-	-	A	-
n2-03	Speed Feedback Detection Control (AFR) Time Constant 2 AFR Time 2	Sets the time constant to control the amount of change in the speed at low speed.	0 to 2000	750ms	-	-	A	-
High Slip Braking								
n3-01	High Slip Braking Deceleration Frequency Width HSB Decel Width	Sets how aggressively the Drive decreases the output frequency as it stops the motor using high slip braking (HSB). If Overvoltage (OV) faults occur during HSB, this parameter may need to be increased.	1 to 20	5%	A	A	-	-
n3-02	High Slip Braking Current Limit HSB Current Ref	Sets the maximum current to be drawn during an HSB stop. Higher n3-02 settings will shorten motor stopping times but cause increased motor current, and therefore increased motor heating.	100 to 200	150%	A	A	-	-
n3-03	High Slip Braking Dwell Time at Stop HSB DwellTim@ Stp	Sets the amount of time the Drive will dwell at E1-09 (Minimum Frequency) at the end of deceleration. If this time is set too low, the machine inertia can cause the motor to rotate slightly after the HSB stop is complete and the Drive output is shut off.	0.0 to 10.0	1.0sec	A	A	-	-
n3-04	High Slip Braking Overload Time HSB OL Time	Sets the time required for an HSB overload fault (OL7) to occur when the Drive output frequency does not change for some reason during an HSB stop. Normally this does not need to be adjusted.	30 to 1200	40sec	A	A	-	-
◆Denotes that parameter can be changed when the Drive is running.								

Table A.1 F7 Parameter List (Continued)

Parameter No.	Parameter Name Digital Operator Display	Description	Setting Range	Factory Setting	Control Method			
					V/F	V/F w/ PG	Open Loop Vector	Flux Vector
Monitor Select								
o1-01 ◆	User Monitor Selection User Monitor Sel	Selects which monitor will be displayed in the operation menu upon power-up when o1-02 = 4.	4 to 45	6	A	A	A	A
o1-02	User Monitor Selection After Power-Up Power-On Monitor	Selects which monitor will be displayed upon power-up. 1: Frequency Reference (U1-01) 2: Output Frequency (U1-02) 3: Output Current (U1-03) 4: User Monitor (set by o1-01)	1 to 4	1	A	A	A	A
o1-03	Digital Operator Display Selection Display Scaling	<p>Sets the units of the Frequency References (d1-01 to d1-17), the Frequency Reference Monitors (U1-01, U1-02, U1-05), and the Modbus communication frequency reference.</p> <p>0: Hz 1: % (100% = E1-04) 2 to 39: RPM (Enter the number of motor poles). 40 to 39999: User display.</p> <p>□□□□ Set the number desired at maximum output frequency. ↑ ↑ 4 digit number Number of digits from the right of the decimal point</p> <p>Example 1: o1-03 = 12000, will result in frequency reference from 0.0 to 200.0 (200.0 = Fmax). Example 2: o1-03 = 21234, will result in frequency reference from 0.00 to 12.34 (12.34 = Fmax).</p>	0 to 39999	0	A	A	A	A
o1-04	Setting unit for frequency parameters related to V/F characteristics Display Units	Sets the setting units related to V/F pattern frequency related parameters (E1-04, -06, -09, -11) 0: Hertz 1: RPM	0 to 1	0	-	-	-	A
o1-05	LCD Brightness Adjustment LCD Contrast	Sets the contrast of the Digital Operator LCD. A setting of "1" is the lightest contrast and a setting of "5" is the darkest contrast.	0 to 5	3	A	A	A	A
◆Denotes that parameter can be changed when the Drive is running.								

Table A.1 F7 Parameter List (Continued)

Parameter No.	Parameter Name Digital Operator Display	Description	Setting Range	Factory Setting	Control Method			
					V/F	V/F w/ PG	Open Loop Vector	Flux Vector
Key Selections								
o2-01	Local/Remote Key Function Selection Local/Remote Key	Determines if the Digital Operator Local/Remote key is functional. 0: Disabled 1: Enabled	0 to 1	1	A	A	A	A
o2-02	STOP Key Function Selection Oper STOP Key	Determines if the STOP key on the Digital Operator will stop the Drive when Drive is operating from external terminals or serial communication. 0: Disabled 1: Enabled	0 to 1	1	A	A	A	A
o2-03	User Parameter Default Value User Defaults	Allows storing of parameter settings as a User Initialization Selection. 0: No Change 1: Set Defaults - Saves current parameter settings as user initialization. A1-03 now allows selecting <1110> for user initialization and returns o2-03 to zero. 2: Clear All - Clears the currently saved user initialization. A1-03 no longer allows selecting <1110> and returns o2-03 to zero.	0 to 2	0	A	A	A	A
o2-04	Drive/kVA Selection Inverter Model #	Sets the kVA of the Drive. Enter the number based on Drive model number. Use the last four digits of the model number. CIMR-F7U□□□□. This parameter only needs to be set when installing a new control board. Do not change for any other reason. Refer to Table B.1.	0 to FF	Varies by kVA	A	A	A	A
o2-05	Frequency Reference Setting Method Selection Operator M.O.P.	Determines if the Data/Enter key must be used to input a frequency reference from the Digital Operator. 0: Disabled - Data/Enter key must be pressed to enter a frequency reference. 1: Enabled - Data/Enter key is not required. The frequency reference is adjusted by the up and down arrow keys on the Digital Operator without having to press the data/enter key.	0 to 1	0	A	A	A	A
o2-06	Operation Selection when Digital Operator is Disconnected Oper Detection	Determines if the Drive will stop when the Digital Operator is removed when in LOCAL mode or b1-02=0. 0: Disabled - The Drive will not stop when the Digital Operator is removed. 1: Enabled - The Drive will fault (OPR) and coast to stop when the Digital Operator is removed.	0 to 1	1	A	A	A	A
o2-07	Cumulative Operation Time Setting Elapsed Time Set	Sets the initial value of the elapsed operation timer U1-13.	0 to 65535	0H	A	A	A	A
o2-08	Cumulative Operation Time Selection Elapsed Time Run	Sets how time is accumulated for the elapsed operation timer U1-13. 0: Power-On Time - Time accumulates when the Drive is powered. 1: Running Time - Time accumulates only when the Drive is running.	0 to 1	0	A	A	A	A
o2-09	Initialization Specification Selection Init Mode Sel	Determines parameter default values after a Drive initialization (A1-03) is executed. This should always be set to "1" for North American installations. 1: American spec 2: European spec	1 to 2	1	A	A	A	A
o2-10	Cumulative Cooling Fan Operation Time Setting Fan ON Time Set	Sets the initial value of the heatsink fan operation time monitor U1-40.	0 to 65535	0H	A	A	A	A
o2-12	Fault Trace/Fault History Clear Function FLT Trace Init	Clears the fault memory contained in the U2 and U3 monitors. 0: Disabled - no effect 1: Enabled - resets U2 and U3 monitors, and returns o2-12 to zero.	0 to 1	0	A	A	A	A
o2-14	kWh User Monitor Initialization kWH MonitorClear	Used to reset the kilowatt-hour monitor U1-29 to zero. 0: Disabled - no change 1: Enabled - Resets U1-29 to zero and returns o2-14 to zero.	0 to 1	0	A	A	A	A

◆ Denotes that parameter can be changed when the Drive is running.

Table A.1 F7 Parameter List (Continued)

Parameter No.	Parameter Name Digital Operator Display	Description	Setting Range	Factory Setting	Control Method			
					V/F	V/F w/ PG	Open Loop Vector	Flux Vector
COPY Function								
o3-01	Copy Function Selection Copy Function Sel	<p>This parameter controls the copying of parameters to and from the Digital Operator.</p> <p>0: COPY SELECT (no function)</p> <p>1: INV -> OP READ - All parameters are copied from the Drive to the Digital Operator.</p> <p>2: OP -> INV WRITE - All parameters are copied from the Digital Operator to the Drive.</p> <p>3: OP<-->INV VERIFY - Parameter settings in the Drive are compared to those in the Digital Operator.</p> <p>NOTE: When using the copy function, the Drive model number (o2-04), software number (U1-14), and control method (A1-02) must match or an error will occur.</p>	0 to 3	0	A	A	A	A
o3-02	Copy Allowed Selection Read Allowable	<p>Enables and disables the Digital Operator copy functions.</p> <p>0: Disabled - No Digital Operator copy functions are allowed.</p> <p>1: Enabled - Copying allowed.</p>	0 to 1	0	A	A	A	A
Auto-Tuning								
T1-00	Motor Selection 1 / 2 Select Motor	<p>Selects which set of motor parameters are to be used and set during Auto-Tuning. If Motor 2 selection (H1-XX=16) is not selected, this parameter will not be displayed.</p> <p>1: 1st Motor - E1 to E2</p> <p>2: 2nd Motor - E3 to E4</p>	1, 2	1	A	A	A	A
T1-01	Auto-Tuning mode selection Tuning Mode Sel	<p>Selects the Auto-Tuning mode.</p> <p>0: Rotational Auto-Tuning (A1-02 = 2 or 3)</p> <p>1: Stationary Auto-Tuning (A1-02 = 2 or 3)</p> <p>2: Terminal resistance only, (stationary) Auto-Tuning (A1-02 = 0, 1, 2, or 3)</p>	0 to 2	0	A	A	A	A
T1-02	Motor Rated Power Mtr Rated Power	<p>Set the motor rated power in kilowatts (kW).</p> <p>NOTE: If motor power is given in horsepower, power in kW can be calculated using the following formula: kW = Hp * 0.746</p>	0.00 to 650.00 kW	Varies by kVA	A	A	A	A
T1-03	Motor rated voltage Rated Voltage	Set the motor rated voltage in Volts (V).	0.0 to 255.0 (240V) 0.0 to 510.0 (480V)	230Vac or 460Vac	-	-	A	A
T1-04	Motor Rated Current Rated Current	Set the motor rated current in Amperes (A).	Varies by kVA	Varies by kVA	A	A	A	A
T1-05	Motor Base Frequency Rated Frequency	Set the base frequency of the motor in Hertz (Hz).	Varies by Duty Rating*	60.0Hz	-	-	A	A
T1-06	Number of Motor Poles Number of Poles	Set the number of motor poles.	2 to 48	4 poles	-	-	A	A
T1-07	Motor Base Speed Rated Speed	Set the base speed of the motor in revolutions per minute (RPM).	0 to 24000	1750 RPM	-	-	A	A
T1-08	Number of PG Pulses PG Pulses / Rev	Set the number of pulses per revolution (PPR) for the encoder (pulse generator) being used without any multiplication factor.	0 to 60000	1024 PPR	-	-	-	A
<p>◆ Denotes that parameter can be changed when the Drive is running.</p> <p>* For Heavy Duty (HD) Rating: Setting Range=0.0 to 300.0. For Normal Duty (ND) Rating: Setting Range=0.0 to 400.0.</p>								

F7 Monitor List

Table A.2 F7 Monitor List			
Parameter No.	Parameter Name Digital Operator Display	Description	Display Units
Monitor			
U1-01	Frequency Reference Frequency Ref	Frequency reference (speed command) monitor when in REMOTE mode, frequency reference (speed command) setting location when in local mode or b1-01 = 0.	Set by o1-03.
U1-02	Output Frequency Output Freq	Output frequency	Set by o1-03.
U1-03	Output Current Output Current	Output current	0.01A
U1-04	Control Method Control Method	Control method set in A1-02. 0 = V/F without PG 1 = V/F with PG 2 = Open Loop Vector 3 = Flux Vector	-
U1-05	Motor Speed Motor Speed	Motor speed feedback	Set by o1-03.
U1-06	Output Voltage Output Voltage	Output voltage	0.1Vac
U1-07	DC Bus Voltage DC Bus Voltage	DC Bus Voltage	1Vdc
U1-08	Output Power Output kWatts	Output power	0.1kW
U1-09	Torque Reference Torque Reference	Torque reference	0.1%
U1-10	Input Terminal Status Input Term Sts	Input terminal status 	-
U1-11	Output Terminal Status Output Term Sts	Output terminal status. 	-

Table A.2 F7 Monitor List (Continued)

Parameter No.	Parameter Name Digital Operator Display	Description	Display Units
U1-12	Drive Operation Status Int Ctl Sts 1	<p>Internal Drive status</p> <p>0 0 0 0 0 0 0 0</p> <p>1: During running 1: During zero speed 1: During reverse 1: During reset signal input 1: During speed agree 1: Drive operation ready 1: During fault detection (Minor fault) 1: During fault detection (Major fault)</p>	-
U1-13	Cumulative Operation Time Elapsed Time	Total operating or power-on time of the Drive.	1hr
U1-14	Software Number FLASH ID	Last 5 digits of the Drive's software number.	-
U1-15	Terminal A1 Input Voltage Term A1 Level	Input voltage on Terminal A1, as a percentage of ±10Vdc.	0.1%
U1-16	Terminal A2 Input Voltage Term A2 level	Displays the input current (or voltage) on Terminal A2, as a percentage of ±10Vdc.	0.1%
U1-17	Terminal A3 Input Voltage Term A3 level	Input voltage on Terminal A3, as a percentage of ±10Vdc.	0.1%
U1-18	Motor Secondary Current (I _q) Mot SEC Current	Current being used by the motor to produce torque (I _q).	0.1%
U1-19	Motor Excitation Current (I _d) Mot EXC Current	Current being used by the motor for excitation (I _d).	0.1%
U1-20	Output Frequency After Soft Start SFS Output	Frequency reference (speed command) after the accel and decel ramps and S-curve.	0.01Hz
U1-21	ASR Input ASR Input	Input error to the speed control loop (ASR). The maximum output frequency E1-04 corresponds to 100%.	0.01%
U1-22	ASR Output ASR Output	Output from the speed control loop (ASR). The motor rated secondary current corresponds to 100%.	0.01%
U1-24	PI Feedback Value PID Feedback	Feedback signal level when PID control is used.	0.01%
U1-25	DI-16H2 Input Status DI-16 Reference	Reference value from a DI-16H2 Digital Reference Card. The value will be displayed in binary or BCD depending on user constant F3-01.	Set by F3-01
U1-26	Output voltage reference (V _q) Voltage Ref (Vq)	Internal voltage reference for motor secondary current control.	0.1Vac
U1-27	Output voltage reference (V _d) Voltage Ref (Vd)	Internal voltage reference for motor excitation current control.	0.1Vac
U1-28	CPU Number CPU ID	Control board hardware revision.	-
U1-29	kWh kWh Lo 4 Digits	Accumulated kilowatt-hours.	0.1kWh
U1-30	MWh kWh Hi 5 Digits	Accumulated megawatt-hours.	1MWh
U1-32	ACR output of q axis ACR(q) Output	Current control output value for the motor secondary current.	0.1%
U1-33	ACR output of d axis ACR(d) Output	Current control output value for the motor excitation current.	0.1%
U1-34	First Parameter Causing an OPE OPE Detected	Parameter number causing an "OPE" fault.	-
U1-35	Zero Servo Pulse Count Zero Servo Pulse	Number of PG pulses times 4 for the movement range when stopped at zero servo.	1 pulse
U1-36	PID Input PID Input	Input error to the PID regulator (PID Setpoint - PID Feedback).	0.01%
U1-37	PID Output PID Output	Output of the PID regulator as a percentage of maximum frequency (E1-04).	0.01%

Table A.2 F7 Monitor List (Continued)

Parameter No.	Parameter Name Digital Operator Display	Description	Display Units
U1-38	PID Setpoint PID Setpoint	Setpoint of the PID regulator (PID reference + PID bias).	0.01%
U1-39	Modbus Communication Error Code Transmit Err	<p>Modbus serial communication error codes.</p> <p>The diagram shows a horizontal row of eight boxes, each containing the digit '0'. Below each box is a vertical line that connects to a label. From right to left, the labels are: '0: Not used. Always 0.', '1: Timeout', '1: Framing error', '1: Overrun error', '1: Parity error', '0: Not used. Always 0.', '1: Data length error', and '1: CRC error'.</p>	-
U1-40	Heatsink Cooling Fan Operation Time FAN Elapsed Time	Total operating time of the heatsink cooling fan.	1hr
U1-44	ASR output without filter ASR out w/o Fil	Output from the speed control loop (ASR) before the ASR primary delay filter (C5-06). 100% is displayed for rated secondary current of the motor.	0.01%
U1-45	Feed forward control output FF Cont Output	Output from feed forward control. 100% is displayed for rated secondary current of the motor.	0.01%

F7 Fault Trace List

Table A.3 F7 Fault Trace List	
Fault Trace	
U2-01	Current Fault. Current Fault
U2-02	Previous Fault. Last Fault
U2-03	Frequency Reference at Previous Fault. Frequency Ref
U2-04	Output Frequency at Previous Fault. Output Freq
U2-05	Output Current at Previous Fault. Output Current
U2-06	Motor Speed at Previous Fault. Motor Speed
U2-07	Output Voltage at Previous Fault. Output Voltage
U2-08	DC Bus Voltage at Previous Fault. DC Bus Voltage
U2-09	Output Power at Previous Fault. Output kWatts
U2-10	Torque Reference at Previous Fault. Torque Reference
U2-11	Input Terminal Status at Previous Fault. The format is the same as for U1-10. Input Term Sts
U2-12	Output Terminal Status at Previous Fault. The format is the same as for U1-11. Output Term Sts
U2-13	Drive Operation Status at Previous Fault. The format is the same as for U1-12. Inverter Status
U2-14	Cumulative Operation Time at Previous Fault. Elapsed time
Note: Fault trace is not executed at CPF00, CPF01, CPF03, UV1, and UV2.	

F7 Fault History List

Table A.4 F7 Fault History List	
Fault History	
U3-01	Most Recent Fault Last Fault
U3-02	2 nd Most Recent Fault Fault Message 2
U3-03	3 rd Most Recent Fault Fault Message 3
U3-04	4 th Most Recent Fault Fault Message 4
U3-05	Cumulative Operation Time at Most Recent Fault Elapsed Time 1
U3-06	Cumulative Operation Time at 2 nd Most Recent Fault Elapsed Time 2
U3-07	Cumulative Operation Time at 3 rd Most Recent Fault Elapsed Time 3
U3-08	Cumulative Operation Time at 4 th Most Recent Fault Elapsed Time 4
U3-09	5 th Most Recent Fault Fault Message 5
U3-10	6 th Most Recent Fault Fault Message 6
U3-11	7 th Most Recent Fault Fault Message 7
U3-12	8 th Most Recent Fault Fault Message 8
U3-13	9 th Most Recent Fault Fault Message 9
U3-14	10 th Most Recent Fault Fault Message 10
U3-15	Cumulative Operation Time at 5 th Most Recent Fault Elapsed Time 5
U3-16	Cumulative Operation Time at 6 th Most Recent Fault Elapsed Time 6
U3-17	Cumulative Operation Time at 7 th Most Recent Fault Elapsed Time 7
U3-18	Cumulative Operation Time at 8 th Most Recent Fault Elapsed Time 8
U3-19	Cumulative Operation Time at 9 th Most Recent Fault Elapsed Time 9
U3-20	Cumulative Operation Time at 10 th Most Recent Fault Elapsed Time 10
Note: Faults such as CPF00, CPF01, CPF02, CPF03, UV1, and UV2 are not stored in fault history.	

Drives Technical Support in USA and Canada

Technical Support for Inverters and Drives is available by phone as follows:

Normal: Monday through Friday during the hours of 8 a.m. to 5:00 p.m. C.S.T.

Emergency: After normal hours, 7 days a week including weekends and holidays

To contact Drives Technical Support, please call 1-800-YASKAWA (927-5292).

From the menu, dial 2 for Inverter and Drive Products, then 5 for Technical Support.

Drives Technical Support can also be reached by e-mail at DriveSupport@yaskawa.com.

Support information, such as technical manuals, FAQs, instruction sheets and software downloads are available at our website, www.drives.com.

When calling for technical support, please have the following materials available:

- The appropriate Technical Manual in hand because the support associate may refer to this
- Complete nameplate information from the drive and the motor.
(Confirm that Drive Nameplate Output amps is greater than Motor Nameplate amps)
- A list with your parameter settings
- A sketch of the electrical powertrain, from AC line to motor, including filters and disconnects

Field Service, Start Up Assistance, Factory Repair, Replacement Parts, and Other Support

Contact Drives Technical Support for help with any of these needs.

Technical Training

Training is conducted at Yaskawa training centers, at customer sites, and via the internet.

For information, visit www.drives.com or call 1-800-YASKAWA (927-5292).

From the phone menu, dial 2 for Inverter and Drive Products, then 4 for Product Training.

Support in Other Countries

Yaskawa is a multi-national company with offices and service representation around the world.

To obtain support, always contact the local distributor first for guidance and assistance.

Contact the closest Yaskawa office listed for further assistance.

YASKAWA ELECTRIC AMERICA, INC.

Drives Division
16555 W. Ryerson Rd., New Berlin, WI 53151, U.S.A.
Phone: (800) YASKAWA (800-927-5292) Fax: (262) 782-3418
Internet: <http://www.drives.com>

YASKAWA ELECTRIC AMERICA, INC.

Chicago-Corporate Headquarters
2121 Norman Drive South, Waukegan, IL 60085, U.S.A.
Phone: (800) YASKAWA (800-927-5292) Fax: (847) 887-7310
Internet: <http://www.yaskawa.com>

MOTOMAN INC.

805 Liberty Lane, West Carrollton, OH 45449, U.S.A.
Phone: (937) 847-6200 Fax: (937) 847-6277
Internet: <http://www.motoman.com>

YASKAWA ELECTRIC CORPORATION

New Pier Takeshiba South Tower, 1-16-1, Kaigan, Minatoku, Tokyo, 105-0022, Japan
Phone: 81-3-5402-4511 Fax: 81-3-5402-4580
Internet: <http://www.yaskawa.co.jp>

YASKAWA ELETRICO DO BRASIL COMERCIO LTDA.

Avenida Fagundes Filho, 620 Bairro Saude Sao Paolo-SP, Brasil CEP: 04304-000
Phone: 55-11-5071-2552 Fax: 55-11-5581-8795
Internet: <http://www.yaskawa.com.br>

YASKAWA ELECTRIC EUROPE GmbH

Am Kronberger Hang 2, 65824 Schwalbach, Germany
Phone: 49-6196-569-300 Fax: 49-6196-888-301

MOTOMAN ROBOTICS AB

Box 504 S38525, Torsas, Sweden
Phone: 46-486-48800 Fax: 46-486-41410

MOTOMAN ROBOTEC GmbH

Kammerfeldstrabe 1, 85391 Allershausen, Germany
Phone: 49-8166-900 Fax: 49-8166-9039

YASKAWA ELECTRIC UK LTD.

1 Hunt Hill Orchardton Woods Cumbernauld, G68 9LF, Scotland, United Kingdom
Phone: 44-12-3673-5000 Fax: 44-12-3645-8182

YASKAWA ELECTRIC KOREA CORPORATION

Paik Nam Bldg. 901 188-3, 1-Ga Euljiro, Joong-Gu, Seoul, Korea
Phone: 82-2-776-7844 Fax: 82-2-753-2639

YASKAWA ELECTRIC (SINGAPORE) PTE. LTD.

Head Office: 151 Lorong Chuan, #04-01, New Tech Park Singapore 556741, Singapore
Phone: 65-282-3003 Fax: 65-289-3003

TAIPEI OFFICE (AND YATEC ENGINEERING CORPORATION)

10F 146 Sung Chiang Road, Taipei, Taiwan
Phone: 886-2-2563-0010 Fax: 886-2-2567-4677

YASKAWA JASON (HK) COMPANY LIMITED

Rm. 2909-10, Hong Kong Plaza, 186-191 Connaught Road West, Hong Kong
Phone: 852-2803-2385 Fax: 852-2547-5773

BEIJING OFFICE

Room No. 301 Office Building of Beijing International Club,
21 Jianguomanwai Avenue, Beijing 100020, China
Phone: 86-10-6532-1850 Fax: 86-10-6532-1851

SHANGHAI OFFICE

27 Hui He Road Shanghai 200437 China
Phone: 86-21-6553-6600 Fax: 86-21-6531-4242

SHANGHAI YASKAWA-TONJI M & E CO., LTD.

27 Hui He Road Shanghai 200437 China
Phone: 86-21-6533-2828 Fax: 86-21-6553-6677

BEIJING YASKAWA BEIKE AUTOMATION ENGINEERING CO., LTD.

30 Xue Yuan Road, Haidian, Beijing 100083 China
Phone: 86-10-6232-9943 Fax: 86-10-6234-5002

SHOUGANG MOTOMAN ROBOT CO., LTD.

7, Yongchang-North Street, Beijing Economic & Technological Development Area,
Beijing 100076 China
Phone: 86-10-6788-0551 Fax: 86-10-6788-2878

YEA, TAICHUNG OFFICE IN TAIWAN

B1, 6F, No.51, Section 2, Kung-Yi Road, Taichung City, Taiwan, R.O.C.
Phone: 886-4-2320-2227 Fax: 886-4-2320-2239